

GEOLOCATION

INSTALLATION INSTRUCTIONS

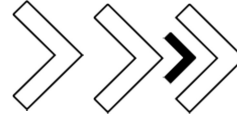

1 INSTALLATION and FIXING



The Interactive Tracker **MUST** be installed:



- ✓ **INSIDE** the car cabin
- ✓ **FRONT** and **TOP** of vehicle
- ✓ **FIXED** to the roll bar with a hose clamp
- ✓ **Screw mounting plate** to dashboard

DO NOT position it
X on the tunnel **X** between the seats



It must be easily accessible and readable for the **DRIVER** and **COPILOT** to press the Interactive Tracker screen in case of emergency

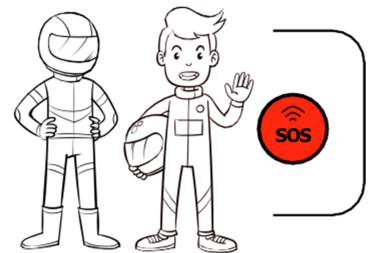

2 CONNECTION & START-UP

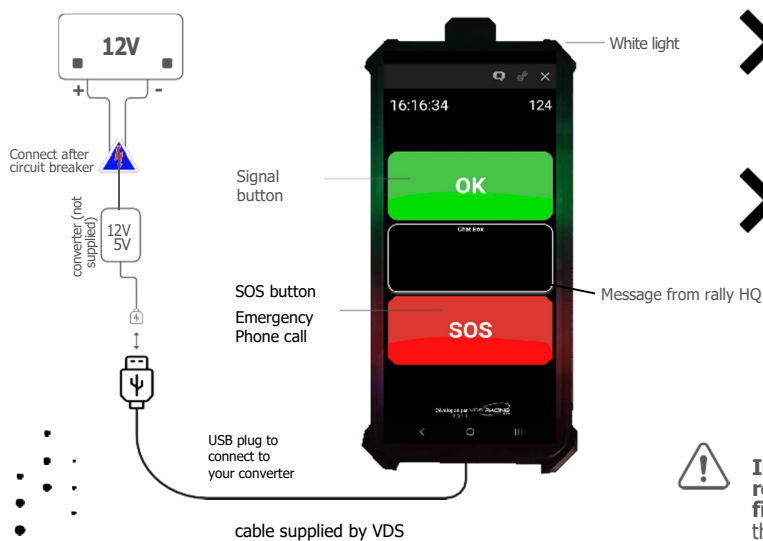

The Interactive Tracker is handed over to you already switched on at the administrative checks. It must be plugged in and **REMAIN ON FOR THE ENTIRE RALLY**.



Connect the interactive tracker direct to your **USB power supply** with the cable supplied. A **WHITE LED** lights up when connected.



Installation of the Interactive Tracker in the race car is the responsibility of the competitor, who must ensure that it is securely fixed in the car cabin and that the box is working. Competitor running off the track or any other incident arising from the Interactive Tracker falling into the competition car.

RESTITUTION

- At the end of the rally, **MANDATORY** return at the entrance to the finish parc fermé.
- In case of withdrawal: Return to RACE HQ ONLY



In exceptional cases and with authorization (tel. 07 68 88 27 57 - 06 95 64 61 76), the Interactive Tracker must be returned the day after the rally.
By post to VDS RACING - 6 place du Comte Raymond VI 30650 Rochefort du Gard

GEOLOCATION

INSTALLATION INSTRUCTIONS

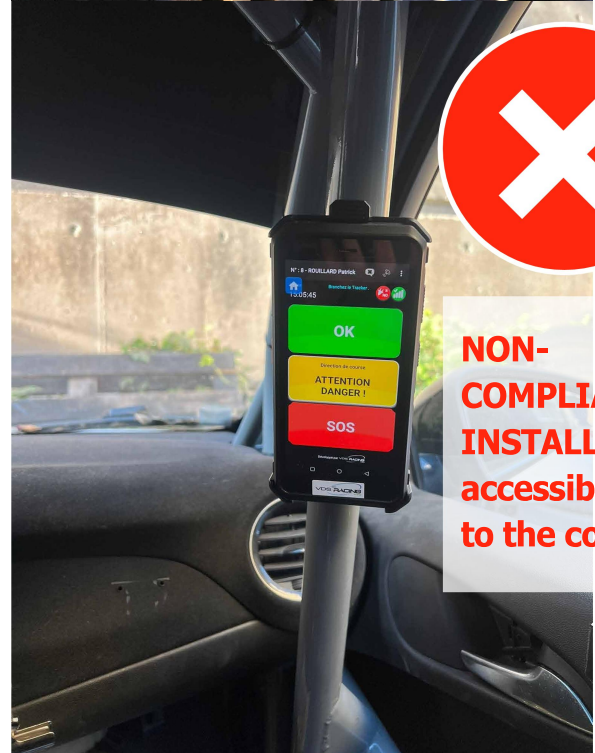
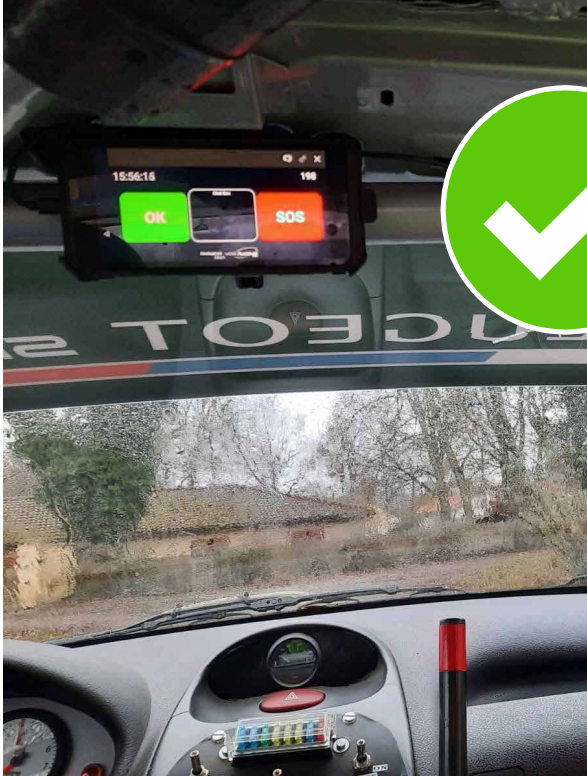

**NON-COMPLIANT
INSTALLATION**
accessible only
to the codriver.

