

CHAMPIONNAT DE FRANCE DES RALLYES



1^{er} e-RALLYE VOSGES Grand Est



Roadbook

1^{er} e-RVGE



TROPHÉE
4290
RALLYE

ADAC OPEL
GSE RALLY CUP



SUIVEZ "RALLYE CLUB" SUR



www.rallyevosgesgrandest.com

Rallye Vosges Grand Est

rallyevosgesgrandest

VOSGES RALLYE
Organisation

VASAC
Vosges

La Région
Grand Est

LE VIEUX
VOSGES
le Département

GÉRARDMER
Hautes Vosges

Les Vosges
vosges

VILLE de
GERARDMER

EC
MANIF
ESTATI
VOSGES

LE JURY
SPORT
AUTOMOBILE
HAUTES VOSGES

ALPINE
STORE NANCY

GT2i

Bureau Vallée
Produits

SECURITEST
CONTROLE TECHNIQUE
Sécurité • Équipement • Contrôle des Véhicules

message

la Comté de
BRESSAUX
40 ANS

EVENTS
COORDINATION
EPR

BEAU RIVAGE
HOTEL

COCKTAIL

1 ^{er} e-RVGE	Concurrent / Crew N°
POINTAGE DES RECONNAISSANCES / RECCES CHECKS	
Fiche à détacher et à rendre lors des vérifications techniques / Form to be detached and returned during the technical verifications	

RAPEL SUR LES MODALITES DES RECONNAISSANCES
 Nous vous demandons la plus grande prudence et le respect impératif des limitations de vitesses, surtout lors de la traversée des nombreuses agglomérations.

REMINDER ON THE MODALITIES OF RECCES
 We ask you to be very careful and the imperative respect of the speed limits, especially when crossing the numerous towns.

Le bon déroulement du rallye en dépend. MERCI d'avance ! / The running of the rally depends on it. THANK YOU in advance!

GENERALITES :

Reconnaisances se déroulent conformément au règlement standard de la FFSA (article 6-2P).
 Le nombre total de passage est limité à 2. Le pointage du carnet de reconnaissance est à la charge de l'équipage. Il devra être rempli au stylo bille, toute infraction sera sanctionnée par le Collège des Commissaires Sportifs.

GENERAL :

Recces will be conducted in accordance with the standard regulations of the FFSA (article 6-2P). The total number of passes is limited to 2. The checking of the recces booklet is the responsibility of the crew. It must be filled in with a ballpoint pen, any infraction will be sanctioned by the Stewards' College.

PENALITES : Reconnaissances en dehors des jours et heures autorisés ou non respect du nombre de passage :
PENALTIES: Recces outside the authorized days and hours or not respecting the number of passages:

- Départ refusé, / Start refused,
- Amende identique à la valeur des droits d'engagement du rallye, / Fine identical to the value of the entry fees of the rally,
- Demande de sanctions disciplinaires auprès de la FFSA. / Request for disciplinary sanctions to the FFSA.
- LES TROIS PENALITES SONT CUMULEES. / THE THREE PENALTIES ARE CUMULATIVE.

RAPPEL DES PENALITES EN CAS D'EXCES DE VITESSE / PENALTIES FOR SPEEDING :

Vitesse / Speed	Amende / Fine	Pénalités / Penalties
1^{ère} infraction notifiée / 1st offence reported :		
Jusqu'à / up to 20 km/h :	68 €	
Jusqu'à / up to 30 km/h :	135 €	10 secondes
Jusqu'à / up to 40 km/h :	135 €	20 secondes
Supérieur à / over 40 km/h :	135 €	1 minute
2^{ème} infraction notifiée / 2nd offence reported :		
En plus de la 1 ^{ère} :	270 €	1 minute
3^{ème} infraction notifiée / 3rd offence reported :		
En plus des deux premières / in addition to the two firsts :	405 €	5 minutes pouvant aller jusqu'à la disqualification 5 minutes up to and including disqualification

HORAIRES : / HOURS :

1^{ère} / st Session	Samedi 7 Juin 2025 de 8h00 à 21h00 / Saturday, 7 th June 2025 between 08h00 and 21h00 Dimanche 8 Juin 2025 de 7h00 à 14h00 / Sunday, 8 th June 2025 between 07h00 and 14h00 ES 9-12 Les Trois Cols autorisées uniquement à partir de 14h00 & ES 3-6 Corcieux interdites de 15h00 à 17h00 SS 9-12 Les Trois Cols only permitted from 2:00 PM & SS 3-6 Corcieux prohibited from 3:00 PM to 5:00 PM
2^{ème} / nd Session	Jeudi 12 Juin 2025 de 8h00 à 21h00 / Thursday, 12 th June 2025 between 08h00 and 21h00 Vendredi 13 Juin 2025 de 7h00 à 14h00 / Friday, 13 th June 2025 between 07h00 and 14h00 (ES8/11 "Corcieux" interdite car shakedown / SS8/11 "Corcieux" forbidden due to shakedown)

1^{er} e-RVGE	Concurrent / Crew N°
POINTAGE DES RECONNAISSANCES / RECCES CHECKS	
Fiche à détacher et à rendre lors des vérifications techniques / Form to be detached and returned during the technical verifications	

Epreuve chronométrée e1-3-6 / SS e1-3-6 "Corcieux"

	heure départ / start time	heure intermédiaire / inter time	heure arrivée / finish time
1^{er/st} passage			
2^{ème/nd} passage			

Epreuve chronométrée 7 / SS 7 "Vologne"

	heure départ / start time	heure intermédiaire / inter time	heure arrivée / finish time
1^{er/st} passage			
2^{ème/nd} passage			

Epreuve chronométrée 11 / SS 11 "Le Haut du Tô't"

	heure départ / start time	heure intermédiaire / inter time	heure arrivée / finish time
1^{er/st} passage			
2^{ème/nd} passage			

Epreuve chronométrée 9-12 / SS 9-12 "Les Trois Cols"

	heure départ / start time	heure intermédiaire / inter time	heure arrivée / finish time
1^{er/st} passage			
2^{ème/nd} passage			

Numero Ligne Sécurité / Security Line Number

PAGE

A

Numéro Ligne Sécurité - Abandon /
Security Line Number - Retirement

07 84 26 52 55 /
+33 7 84 26 52 55

1er e-RVGE

**FORMULAIRE A REMPLIR EN CAS D'ABANDON
NOTIFICATION OF WITHDRAWAL FROM RALLY**

**PAGE
B**

Numéro de voiture / Car N° :

Nom du Pilote / Name of Driver :

Numéro et nom ES / N° and name SS :

Etape / Leg

Raison de l'abandon / Reasons of withdrawal :

ABANDON DEFINITIF / FINAL RETIREMENT

Je désire ne pas participer au re-départ / I didn't participated at restart

Dans ce cas, cochez cette case / In this case, tick this box :

Téléphone du pilote / Phone driver :

Signature du pilote / Signature driver :

RECEPTION DE LA DECLARATION / DECLARATION RECEIPT

Nom du Pilote / Name of driver :

Voiture N° / Car N° :

Date et heure / Date and hour

Nom de l'officiel / Name of officer :

Signature / Signed :

Numéro Téléphone Urgence / Urgency : + 33 (0)7 84 26 52 55

Numéro Téléphone Secrétariat Rallye / Rally control secretary : + 33(0)6 83 43 92 29

Numéro Téléphone Redépart / Restart after retirement













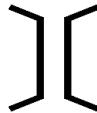



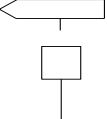





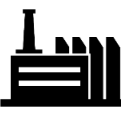

Abandon / Withdrawal

+ 33 (0)7 84 26 52 55

Service dépannage / Breakdown service

Liste des symboles utilisés dans le Road-Book /
symbols used in the Road-Book

List of

	CONTRÔLE HORAIRE / HOURLY CONTROL		DEBUT DE ZONE CASQUE / HELMET ZONE START		PONT / BRIDGE
	DÉPART SPÉCIALE / SS START		FIN DE ZONE CASQUE / HELMET ZONE END		VOIE FERREE / RAILWAY
	ARRIVÉE SPÉCIALE / SS FINISH		PANCARTE / SIGNALIZATION		ÉGLISE / CHURCH
	POINT STOP / STOP POINT		ENTRÉE VILLE OU VILLAGE / TOWN ENTRANCE		MAISON / HOUSE
	CONTRÔLE DE PASSAGE / PASSAGE CONTROL		SORTIE VILLE OU VILLAGE / TOWN EXIT		USINE / FACTORY
	ROUTE A SUIVRE / ROAD TO FOLLOW		STOP / STOP		HAIE / HEDGE
	ROUTE A NE PAS SUIVRE / ROAD NOT TO FOLLOW		CÉDER LE PASSAGE / YIELD TO THE TRAFFIC		SANS INDICATION / NO INDICATION
	DIRECTION A NE PAS SUIVRE / DIRECTION NOT TO FOLOW		FEUX / TRAFFIC LIGHTS		SUIVRE ROUTE PRINCIPALE / FOLLOW MAIN ROAD
	POINT RADIO EN ES / SS RADIO POINT		SENS INTERDIT / PROHIBITED DIRECTION		TOURNER LA PAGE RAPIDEMENT / TURN THE PAGE QUICKLY

RECONNAISSANCES
DÉBUT DE ZONE
À
VITESSE
LIMITÉE
CONTRÔLES
FFSAI

RECOS DEBUT DE ZONE A
VITESSE LIMITEE / RECCE
START OF LIMITED SPEED
ZONE

RECONNAISSANCES
FIN DE ZONE
A
VITESSE
LIMITÉE
CONTRÔLES
FFSAI

RECOS FIN DE ZONE A
VITESSE LIMITEE / RECCE
END OF LIMITED SPEED
ZONE



CH PARC ASSISTANCE & PARC FERME
SERVICE PARK & PARC FERME TC

Trophée Alpine A290 Rallye : Parking de la Prairie, Gérardmer
ADAC Opel GSE Rally Cup : Parking du Casino, Gérardmer

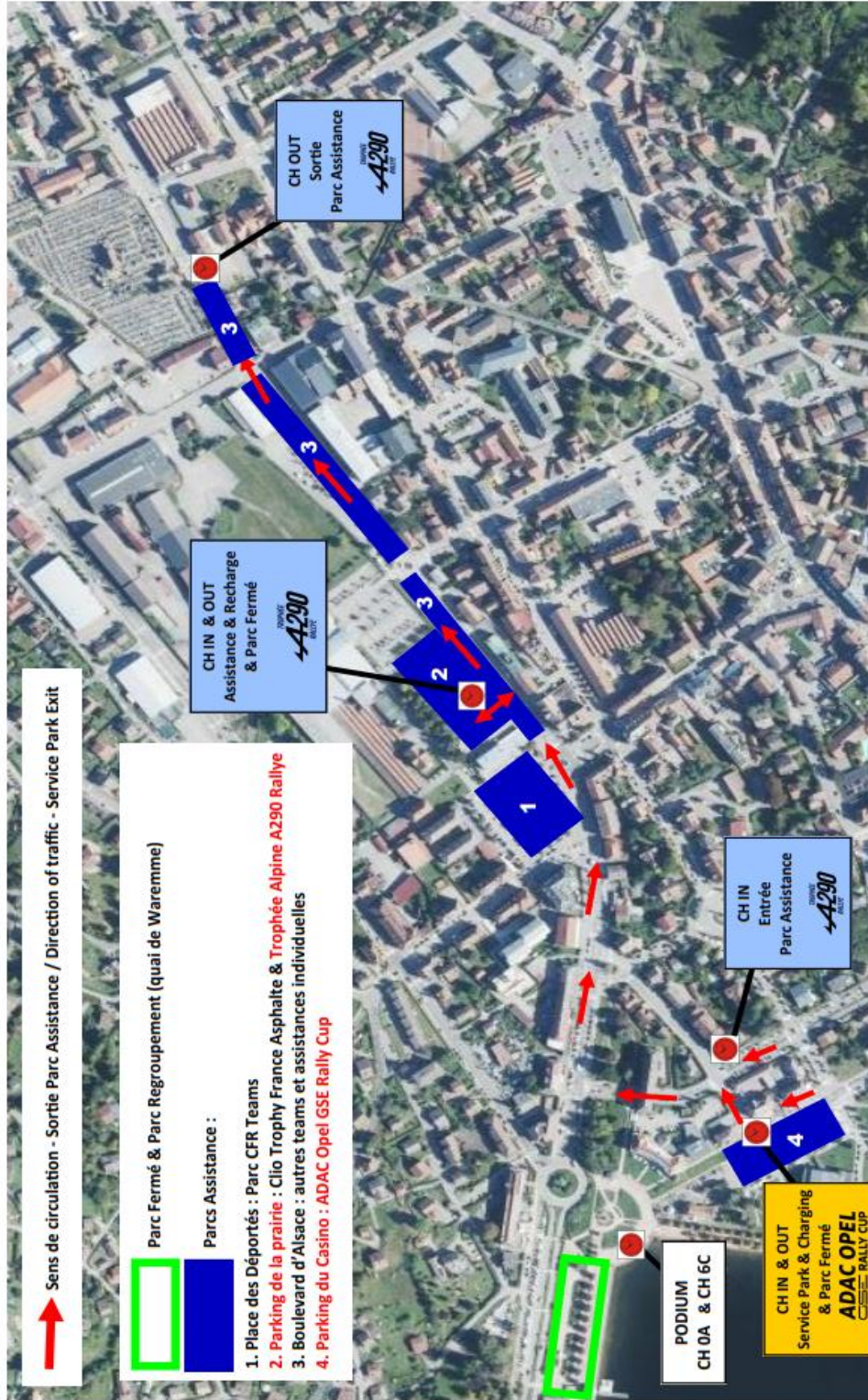



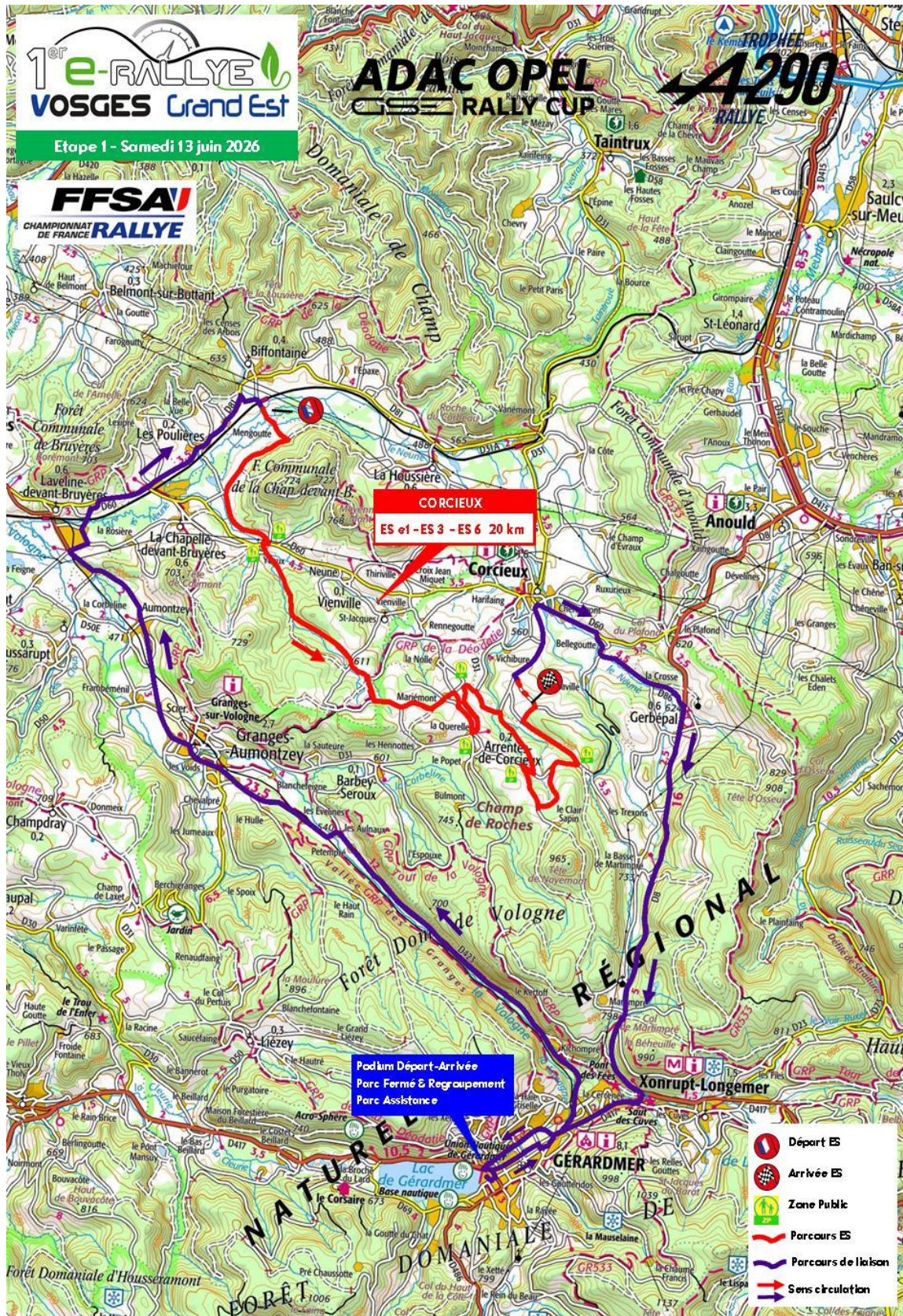

ITINERAIRE & CONTROLES - Version du 3/04/2026									
Etape 1- samedi 13 juin 2026									
		Trophée A290 Rallye			ADAC OPEL GSE RALLY CUP				
CH ES	Lieux	ES Km	Liaison Km	Total Km	ES Km	Liaison Km	Total Km	Target Time	1 ^{er} A290
CH 0A	Parc Fermé OUT / Assistance IN - Gérardmer		0,66	0,00		0,29	0,29		
ASSISTANCE A - Gérardmer (parking de la prairie / parking du Casino)								00:25	
CH 0B	Assistance OUT - Gérardmer		1,16	1,16		0,29	0,58		08:20
CH e1	Rue de la gare (Biffontaine)		22,96	24,12		24,02	24,60	00:35	08:55
ES e1	Corcieux I		0,16	24,28		0,16	24,76	00:03	08:58
	Arrivée ES e1	20,00		44,28	20,00		44,76		
	Point Stop ES e1		0,69	44,97		0,69	45,45		
CH e1A	Regroupement & Recharge IN - Gérardmer		18,01	62,98		18,08	63,53	00:55	09:53
REGROUPEMENT & RECHARGE - Gérardmer (parking de la prairie / parking du Casino)								02:57	
CH e1B	Regroupement OUT - Assistance IN - Gérardmer		0,58	63,56		0,00	63,53		12:50
ASSISTANCE B - Gérardmer (parking de la prairie / parking du Casino)								01:15	
CH e1C	Assistance OUT - Gérardmer		0,58	63,56		0,00	63,53		14:05
CH 3	Rue de la gare (Biffontaine)		22,96	86,52		24,02	87,55	00:35	14:40
ES 3	Corcieux II		0,16	86,68		0,16	87,71	00:03	14:43
	Arrivée ES 3	20,00		106,68	20,00		107,71		
	Point Stop ES 3		0,69	107,37		0,69	108,40		
CH 3A	Regroupement & Recharge IN - Gérardmer		18,01	125,38		18,08	126,48	00:55	15:38
REGROUPEMENT & RECHARGE - Gérardmer (parking de la prairie / parking du Casino)								02:36	
CH 3B	Regroupement OUT - Assistance IN - Gérardmer		0,58	125,96		0,00	126,48		18:14
ASSISTANCE C - Gérardmer (parking de la prairie / parking du Casino)								01:15	
CH 3C	Assistance OUT - Gérardmer		0,58	125,96		0,00	126,48		19:29
CH 6	Rue de la gare (Biffontaine)		22,96	148,92		24,02	150,50	00:35	20:04
ES 6	Corcieux III		0,16	149,08		0,16	150,66	00:03	20:07
	Arrivée ES 6	20,00		169,08	20,00		170,66		
	Point Stop ES 6		0,69	169,77		0,69	171,35		
CH 6A	Assistance IN - Gérardmer		18,01	187,78		18,08	189,43	00:55	21:02
ASSISTANCE D - Gérardmer (parking de la prairie / parking du Casino)								00:45	
CH 6B	Assistance OUT & Parc Fermé & Recharge IN - Gérardmer		0,58	188,36		0,00	189,43		21:47
	PARC FERME - Gérardmer		0,00	188,36		0,00	189,43		
Total Etape 1 - Trophée Alpine A290 Rallye		60,00	130,18	190,18					32%
Total Etape 1 - ADAC Opel GSE Rally Cup					60,00	129,43	189,43		32%

ETAPE 1 / LEG 1



1er e-RVGE

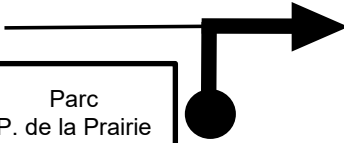

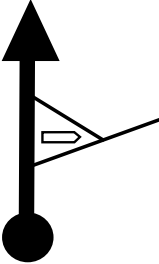
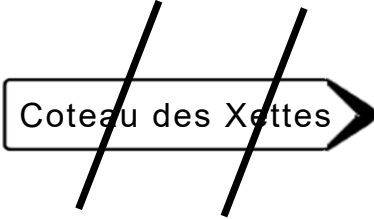
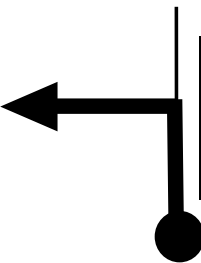
CH	-	-	SECTION 1	DISTANCE 0,66 km	PAGE 2
CH	0A	Parc Fermé OUT / Assistance IN			
EPREUVE SPECIALE / SPECIAL STAGE			VITESSE MOYENNE / AVERAGE SPEED	TEMPS IMPARTI / TARGET TIME	
ES/SS					

DISTANCE		DIRECTIONS	INFORMATIONS	DISTANCE DEGRESSIVE
TOTALE	PARTIELLE			
0,00	0,00	<p>PARC</p> 	<p><u>Parc Trophée A290 Rallye</u></p> <div style="border: 1px solid black; padding: 5px; display: inline-block;">  N 48°4'20.1" E 6°52'23.6" </div>	0,66
0,09	0,09	 <p>Parc P. de la Prairie</p>	S.I. / N.I.	0,57
0,14	0,05	 <div style="display: flex; justify-content: space-around; align-items: center;"> <div style="border: 1px solid black; padding: 2px; font-size: 8px;">Au Pain de mon Grand-Père</div> <div style="text-align: center;">Parc Team</div> <div style="border: 1px solid black; padding: 2px; font-size: 8px;">OFFICE DU TOURISME</div> </div> <div style="border: 1px solid black; padding: 2px; font-size: 8px; margin-top: 5px;">Papa Gâteau</div>	S.I. / N.I.	0,52
0,22	0,08	 <div style="background-color: black; color: red; padding: 5px; font-weight: bold; font-size: 12px; margin: 5px 0;">AU COURÂGE</div>	 <p>Coteau des Xettes</p>	0,44
0,46	0,24	 <div style="border: 1px solid black; padding: 2px; font-size: 8px; margin-top: 5px;">Bar à Vins Restaurant</div>	S.I. / N.I.	0,20

Assistance interdite sur l'ensemble du parcours / Assistance forbidden on the whole course

1er e-RVGE

CH	-	-	SECTION 1	DISTANCE 0,66 km	PAGE 3
CH	0A	Parc Fermé OUT / Assistance IN			
EPREUVE SPECIALE / SPECIAL STAGE			VITESSE MOYENNE / AVERAGE SPEED	TEMPS IMPARTI / TARGET TIME	
ES/SS					

DISTANCE		DIRECTIONS	INFORMATIONS	DISTANCE DEGRESSIVE
TOTALE	PARTIELLE			
0,51	0,05		S.I. / N.I.	0,15
0,59	0,08		S.I. / N.I.	0,07
0,63	0,04		S.I. / N.I.	0,03
0,66	0,03		 <p>CH 0A Parc Fermé OUT / Assistance IN</p> <div style="border: 1px solid black; padding: 5px; width: fit-content;">  <p>N 48° 4'15.4" E 6°52'1.2"</p> </div>	0,00

3

1er e-RVGE

CH	-	-	SECTION	DISTANCE	PAGE
CH	0A	Parc Fermé OUT / Assistance IN	1	0,29 km	
EPREUVE SPECIALE / SPECIAL STAGE			VITESSE MOYENNE / AVERAGE SPEED	TEMPS IMPARTI / TARGET TIME	2 BIS
ES/SS			-	-	

DISTANCE		DIRECTIONS	INFORMATIONS	DISTANCE DEGRESSIVE
TOTALE	PARTIELLE			
0,00	0,00		Sortie Parc Fermé / Exit from the Parc Fermé 	0,29
0,08	0,08		S.I. / N.I.	0,21
0,14	0,06		S.I. / N.I.	0,15
0,22	0,08		S.I. / N.I.	0,07
0,26	0,04		S.I. / N.I.	0,03

1

Assistance interdite sur l'ensemble du parcours / Assistance forbidden on the whole course

1er e-RVGE					
CH	-	-	SECTION	DISTANCE	PAGE
CH	0A	Parc Fermé OUT / Assistance IN	1	0,29 km	
EPREUVE SPECIALE / SPECIAL STAGE			VITESSE MOYENNE / AVERAGE SPEED	TEMPS IMPARTI / TARGET TIME	3 BIS
ES/SS			-	-	
DISTANCE		DIRECTIONS	INFORMATIONS		DISTANCE DEGRESSIVE
TOTALE	PARTIELLE				
0,29	0,03	<p>PODIUM</p> <p>2</p>	<p>CH 0A Parc Fermé OUT / Assistance IN</p> <div style="border: 1px solid black; padding: 5px; display: inline-block;"> N 48° 4'15.4" E 6°52'1.2" </div>	0,00	

SECTION 1 CH 0A

C.H. 0A Parc Fermé OUT / Service IN

N 48° 4'15.4" E 6°52'1.2"

1er e-RVGE

CH	0A	Parc Fermé OUT / Assistance IN	SECTION	DISTANCE	PAGE
CH	0B	Assistance OUT	1	0,29 km	
EPREUVE SPECIALE / SPECIAL STAGE			VITESSE MOYENNE / AVERAGE SPEED	TEMPS IMPARTI / TARGET TIME	4 BIS
ES/SS			-	00h25mn	

DISTANCE		DIRECTIONS	INFORMATIONS	DISTANCE DEGRESSIVE
TOTALE	PARTIELLE			
0,00	0,00	<p>PODIUM</p>	<p>CH 0A Parc Fermé OUT / Service IN</p> <div style="border: 1px solid black; padding: 2px; width: fit-content;"> N 48° 4'15.4" E 6°52'1.2" </div>	0,29
0,05	0,05	<p>Glacier</p>	S.I. / N.I.	0,24
0,13	0,08		S.I. / N.I.	0,16
0,20	0,07	<p>Hôtel de la PAIX</p> <p>STOP</p>	S.I. / N.I.	0,09
0,29	0,09	<p>JOACASINO</p> <p>PARK ADAC OPEL RALLY CUP</p> <p>Hôtel de la PAIX</p>	ADAC OPEL GSE Rally Cup Assistance Entrance	0,00

Assistance interdite sur l'ensemble du parcours / Assistance forbidden on the whole course

1er e-RVGE					
CH	0A	Parc Fermé OUT / Assistance IN	SECTION	DISTANCE	PAGE
CH	0B	Assistance OUT	1	0,29 km	
EPREUVE SPECIALE / SPECIAL STAGE			VITESSE MOYENNE / AVERAGE SPEED	TEMPS IMPARTI / TARGET TIME	5 BIS
ES/SS			-	00h25mn	
DISTANCE		DIRECTIONS	INFORMATIONS	DISTANCE DEGRESSIVE	
TOTALE	PARTIELLE			0,00	0,00

SECTION 1 | CH 0B

C.H. 0B Assistance OUT

N 48° 4'12.2" E 6°52'4.7"



1er e-RVGE

CH	0B	Assistance OUT	SECTION	DISTANCE	PAGE
CH	e1	Avant ES e1 / Before SS e1 "Corcieux"	1	24,02 km	
EPREUVE SPECIALE / SPECIAL STAGE			VITESSE MOYENNE / AVERAGE SPEED	TEMPS IMPARTI / TARGET TIME	6 BIS
ES/SS			41,18 km/h	00h35mn	

DISTANCE		DIRECTIONS	INFORMATIONS	DISTANCE DEGRESSIVE
TOTALE	PARTIELLE			
0,00	0,00		CH 0B Assistance OUT N 48° 4'15.4" E 6°52'1.2"	24,02
0,08	0,08		S.I. / N.I.	23,94
0,19	0,11		S.I. / N.I.	23,83
0,43	0,24		Coteau des Xettes	23,59
0,51	0,08		puis reprendre / then resume Case 5 page 6 à / at 0,23 km	23,51

Assistance interdite sur l'ensemble du parcours / Assistance forbidden on the whole course



1er e-RVGE					
CH	0A	Parc Fermé OUT / Assistance IN	SECTION	DISTANCE	PAGE
CH	0B	Assistance OUT	1	1,16 km	
EPREUVE SPECIALE / SPECIAL STAGE			VITESSE MOYENNE / AVERAGE SPEED	TEMPS IMPARTI / TARGET TIME	4
ES/SS			2,78 km/h	00h25mn	

SECTION 1	CH 0A
-----------	-------

C.H. 0A Parc Fermé OUT / Assistance IN

 N 48° 4'15.4" E 6°52'1.2"

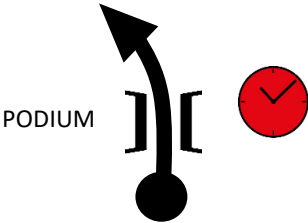

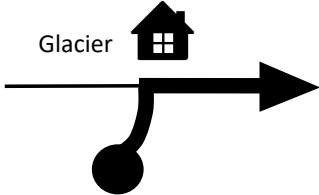
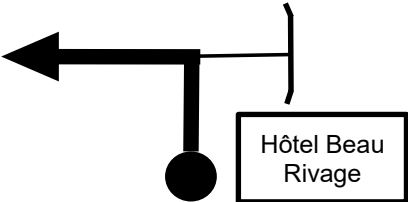
DISTANCE		DIRECTIONS	INFORMATIONS	DISTANCE DEGRESSIVE
TOTALE	PARTIELLE			
0,00	0,00		 CH 0A Parc Fermé OUT / Assistance IN <div style="border: 1px solid black; padding: 5px; width: fit-content; margin: 10px auto;">  N 48° 4'15.4" E 6°52'1.2" </div>	1,16
0,05	0,05		S.I. / N.I.	1,11
0,13	0,08		S.I. / N.I.	1,03
		1		

Assistance interdite sur l'ensemble du parcours / Assistance forbidden on the whole course

1er e-RVGE

CH	0A	Parc Fermé OUT / Assistance IN	SECTION 1	DISTANCE 1,16 km	PAGE 5
CH	0B	Assistance OUT			
EPREUVE SPECIALE / SPECIAL STAGE			<small>VITESSE MOYENNE / AVERAGE SPEED</small> 2,78 km/h	<small>TEMPS IMPARTI / TARGET TIME</small> 00h25mn	
ES/SS					

DISTANCE		DIRECTIONS	INFORMATIONS	DISTANCE DEGRESSIVE
TOTALE	PARTIELLE			
0,18	0,05	<div style="border: 1px solid black; padding: 5px; margin-bottom: 5px;"> </div> <div style="border: 1px solid black; padding: 5px; margin-bottom: 5px;"> </div> <div style="border: 1px solid black; padding: 5px; display: inline-block;">2</div>	S.I. / N.I.	0,98
0,42	0,24	<div style="border: 1px solid black; padding: 5px; margin-bottom: 5px;"> </div> <div style="border: 1px solid black; padding: 5px; margin-bottom: 5px;"> </div> <div style="border: 1px solid black; padding: 5px; display: inline-block;">3</div>	S.I. / N.I.	0,74
0,50	0,08	<div style="border: 1px solid black; padding: 5px; margin-bottom: 5px;"> </div> <div style="border: 1px solid black; padding: 5px; margin-bottom: 5px;"> </div> <div style="border: 1px solid black; padding: 5px; margin-bottom: 5px;"> </div> <div style="border: 1px solid black; padding: 5px; margin-bottom: 5px;"> </div>	S.I. / N.I.	0,66
0,59	0,09	<div style="border: 1px solid black; padding: 5px; margin-bottom: 5px;"> </div> <div style="border: 1px solid black; padding: 5px; margin-bottom: 5px;"> </div> <div style="border: 1px solid black; padding: 5px; margin-bottom: 5px;"> </div>	<u>Parc Trophée A290 Rallye</u> <u>Entrée Assistance</u>	0,57
0,68	0,09	<div style="border: 1px solid black; padding: 5px; margin-bottom: 5px;"> </div> <div style="border: 1px solid black; padding: 5px; margin-bottom: 5px;"> </div> <div style="border: 1px solid black; padding: 5px; display: inline-block;">4</div>	S.I. / N.I.	0,48

Assistance interdite sur l'ensemble du parcours / Assistance forbidden on the whole course

1er e-RVGE						
CH	0A	Parc Fermé OUT / Assistance IN		SECTION	DISTANCE	PAGE
CH	0B	Assistance OUT		1	1,16 km	
EPREUVE SPECIALE / SPECIAL STAGE				VITESSE MOYENNE / AVERAGE SPEED	TEMPS IMPARTI / TARGET TIME	6
ES/SS				2,78 km/h	00h25mn	
DISTANCE		DIRECTIONS		INFORMATIONS	DISTANCE DEGRESSIVE	
TOTALE	PARTIELLE					
0,87	0,19	5		S.I. / N.I.	0,29	
1,08	0,21			S.I. / N.I.	0,08	
1,16	0,08	6		CH 0B Assistance OUT N 48°4'28.0" E 6°52'43.1"	0,00	

SECTION 1 CH 0B

C.H.0B Assistance OUT

N 48°4'28.0" E 6°52'43.1"

1er e-RVGE

CH	0B	Service OUT	SECTION	DISTANCE	PAGE
CH	e1	Avant ES e1 / Before SS e1 "Corcieux"	1	22,96 km	
EPREUVE SPECIALE / SPECIAL STAGE			VITESSE MOYENNE / AVERAGE SPEED	TEMPS IMPARTI / TARGET TIME	7
ES/SS			39,36 km/h	00h35min	

DISTANCE		DIRECTIONS	INFORMATIONS	DISTANCE DEGRESSIVE
TOTALE	PARTIELLE			
0,00	0,00			22,96
0,07	0,07			22,89
0,28	0,21			22,68
0,37	0,09			22,59
0,55	0,18			22,41











1er e-RVGE

CH	0B	Service OUT	SECTION	DISTANCE	PAGE
CH	e1	Avant ES e1 / Before SS e1 "Corcieux"	1	22,96 km	
EPREUVE SPECIALE / SPECIAL STAGE			VITESSE MOYENNE / AVERAGE SPEED	TEMPS IMPARTI / TARGET TIME	8
ES/SS			39,36 km/h	00h35min	

DISTANCE		DIRECTIONS	INFORMATIONS	DISTANCE DEGRESSIVE
TOTALE	PARTIELLE			
0,76	0,21		D417 COLMAR XONRUPT - LONGEMER BRUYERES SAINT - DIÉ	22,20
0,89	0,13		D423 GRANGES^s / V. BRUYÈRES KICHOMPRE LE KERTOFF	22,07
1,41	0,52		SRP / FMR D423	21,55
2,39	0,98		SRP / FMR D423	20,57
3,29	0,90		SRP / FMR D423	19,67

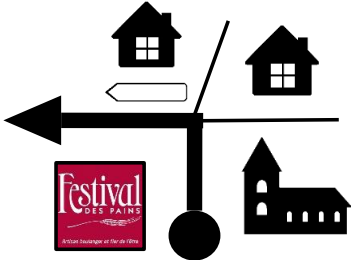
1er e-RVGE









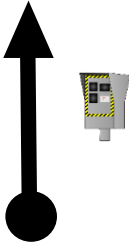

CH	0B	Service OUT	SECTION 1	DISTANCE 22,96 km	PAGE 9
CH	e1	Avant ES e1 / Before SS e1 "Corcieux"			
EPREUVE SPECIALE / SPECIAL STAGE			VITESSE MOYENNE / AVERAGE SPEED	TEMPS IMPARTI / TARGET TIME	
ES/SS			39,36 km/h	00h35min	

DISTANCE		DIRECTIONS	INFORMATIONS	DISTANCE DEGRESSIVE
TOTALE	PARTIELLE			
3,98	0,69	  8	SRP / FMR D423	18,98
4,62	0,64	  9	SRP / FMR D423	18,34
11,30	6,68	  10	SRP / FMR D423	11,66
12,49	1,19	 11	  et SRP / and FMR D423	10,47
13,68	1,19	  12	SRP / FMR D423	9,28

Assistance interdite sur l'ensemble du parcours / Assistance forbidden on the whole course

1er e-RVGE

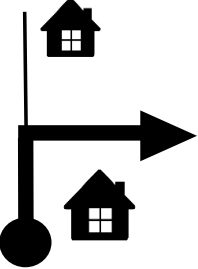

CH	0B	Service OUT	SECTION 1	DISTANCE 22,96 km	PAGE 10
CH	e1	Avant ES e1 / Before SS e1 "Corcieux"			
EPREUVE SPECIALE / SPECIAL STAGE			VITESSE MOYENNE / AVERAGE SPEED	TEMPS IMPARTI / TARGET TIME	
ES/SS			39,36 km/h	00h35min	

DISTANCE		DIRECTIONS	INFORMATIONS	DISTANCE DEGRESSIVE
TOTALE	PARTIELLE			
14,93	1,25	  13	SRP / FMR D423	8,03
15,19	0,26	 14	ATTENTION / WARNING RADAR SRP / FMR D423	7,77
15,71	0,52	   15	SRP / FMR D423	7,25
16,83	1,12	  16	SRP / FMR D423	6,13
17,42	0,59	    17	S.I. / N.I.	5,54

Assistance interdite sur l'ensemble du parcours / Assistance forbidden on the whole course



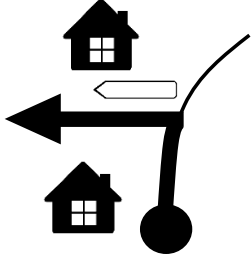

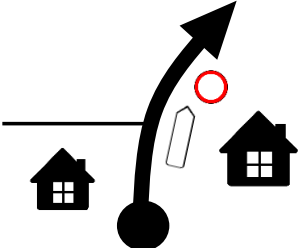
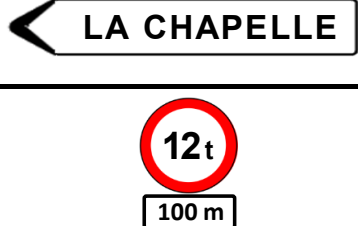
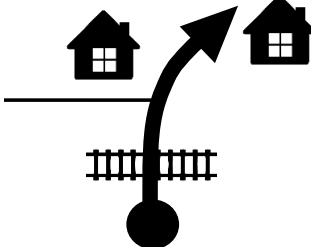
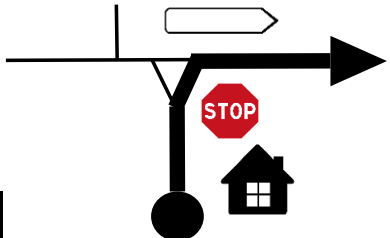
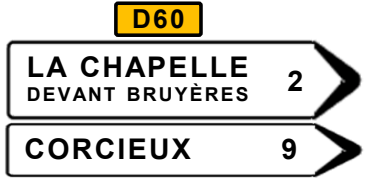
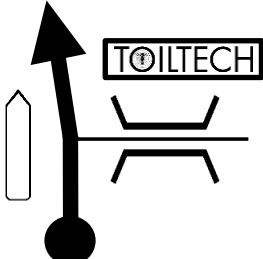
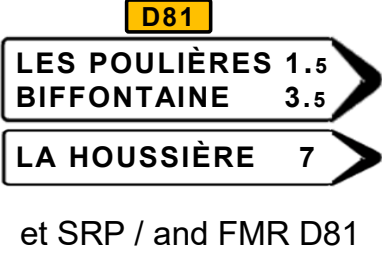





1er e-RVGE

CH	0B	Service OUT	SECTION	DISTANCE	PAGE
CH	e1	Avant ES e1 / Before SS e1 "Corcieux"	1	22,96 km	
EPREUVE SPECIALE / SPECIAL STAGE			VITESSE MOYENNE / AVERAGE SPEED	TEMPS IMPARTI / TARGET TIME	11
ES/SS			39,36 km/h	00h35min	

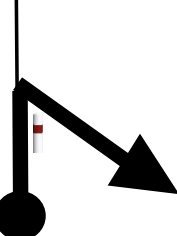
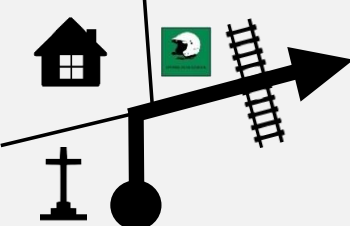
DISTANCE		DIRECTIONS	INFORMATIONS	DISTANCE DEGRESSIVE
TOTALE	PARTIELLE			
17,81	0,39	 18		5,15
18,11	0,30	 19		4,85
18,40	0,29	 20	S.I. / N.I.	4,56
18,82	0,42	 21		4,14
19,85	1,03	 22		3,11

1er e-RVGE

CH	0B	Service OUT	SECTION	DISTANCE	PAGE 12
CH	e1	Avant ES e1 / Before SS e1 "Corcieux"	1	22,96 km	
EPREUVE SPECIALE / SPECIAL STAGE			VITESSE MOYENNE / AVERAGE SPEED	TEMPS IMPARTI / TARGET TIME	
ES/SS			39,36 km/h	00h35min	

DISTANCE		DIRECTIONS	INFORMATIONS	DISTANCE DEGRESSIVE
TOTALE	PARTIELLE			
20,75	0,90	  23	SRP / FMR D81	2,21
21,91	1,16	  24	SRP / FMR D81	1,05
22,46	0,55	  25	S.I. / N.I.	0,50
22,94	0,48		 !!! VOIE FERREE ACTIVE / ACTIVE RAILWAY !!!	0,02
22,96	0,02	  26	 CH e1 Avant ESe1 / Before SSe1  N 48°12'20.5" E 6°48'25.6"	0,00
0,16 km avant Départ ESe1 / before start of SSe1 "Corcieux"				

Assistance interdite sur l'ensemble du parcours / Assistance forbidden on the whole course

1er e-RVGE

EPREUVE SPECIALE / SPECIAL STAGE

SECTION

1

PAGE

13

ES/SS

e1

"Corcieux"

20,00 km

1ère / 1st
A290
08h58

C.H. e1

N 48°12'20.5"
E 6°48'25.6"

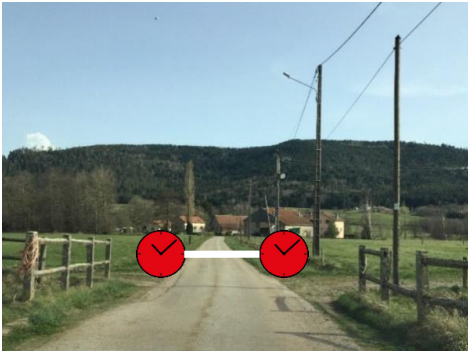

DEPART / START

N 48°12'16.3"
E 6°48'29.4"

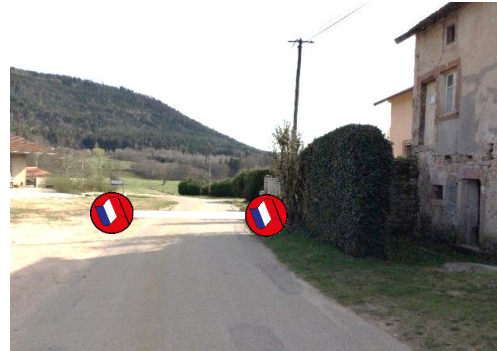

ARRIVEE / FINISH

N 48° 9'12.0"
E 6°52'51.6"



POINT STOP

N 48° 9'29.3"
E 6°52'32.8"



Fermeture de la route à / Road closure at :

1ère/1st car :

08h00 - 23h00

08h58

14



ES 3 - ES 6 Corcieux : 20 km
Samedi 13 juin 2026
 ES 3: 12h04 - ES 6: 17h28
 Horaires sous réserve de modifications.

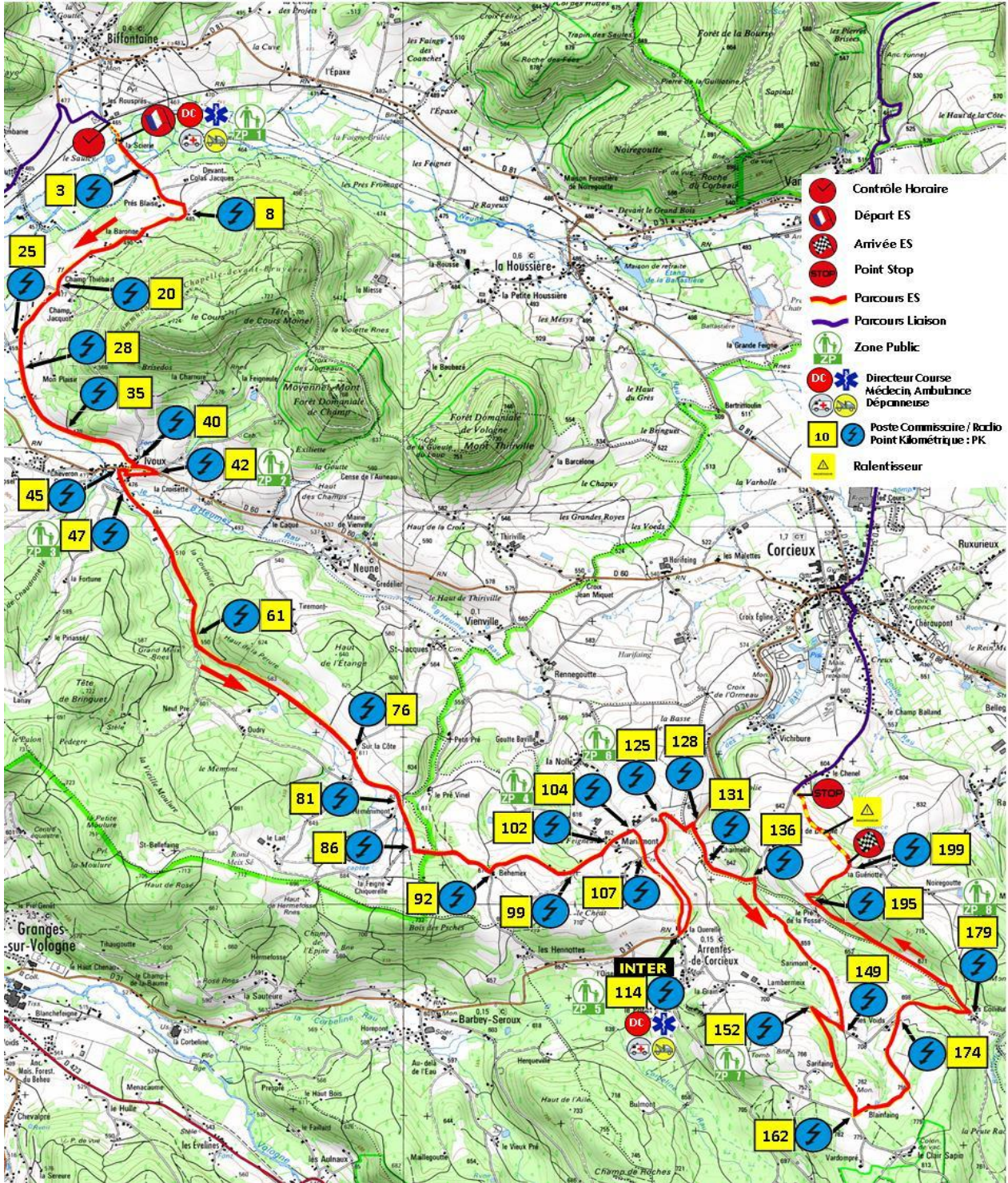

1er e-RVGE







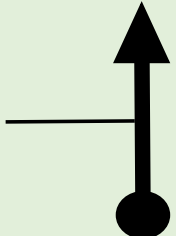
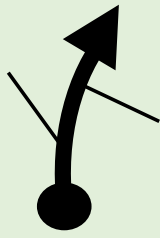

CH	e1	Avant ES e1 / Before SS e1 "Corcieux"	SECTION 1	DISTANCE 38,70 km	PAGE 15
CH	e1A	Regroupement & Recharge IN			
EPREUVE SPECIALE / SPECIAL STAGE			VITESSE MOYENNE / AVERAGE SPEED	TEMPS IMPARTI / TARGET TIME	
ES/SS	e1	"Corcieux" 20,00 km	42,39 km/h	00h55min	

DISTANCE		DIRECTIONS	INFORMATIONS	DISTANCE DEGRESSIVE
TOTALE	PARTIELLE			
0,00	0,00		<p>DEPART / START "CORCIEUX" ES / SS e1 Entre les maisons / Between the houses</p> <p>N 48°12'16.3" E 6°48'29.4"</p>	20,00 38,70
0,52	0,52		S.I. / N.I.	19,48 38,18
0,58	0,06		S.I. / N.I.	19,42 38,12
0,80	0,22		S.I. / N.I.	19,20 37,90
1,22	0,42		S.I. / N.I.	18,78 37,48

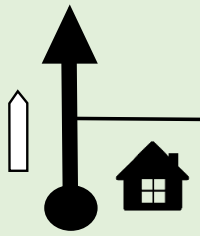
Assistance interdite sur l'ensemble du parcours / Assistance forbidden on the whole course

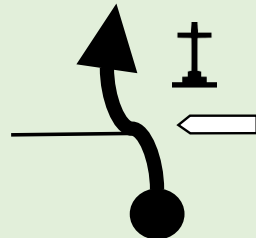
1er e-RVGE

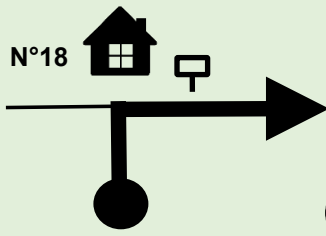
CH	e1	Avant ES e1 / Before SS e1 "Corcieux"	SECTION	DISTANCE	PAGE 16
CH	e1A	Regroupement & Recharge IN	1	38,70 km	
EPREUVE SPECIALE / SPECIAL STAGE			<small>VITESSE MOYENNE / AVERAGE SPEED</small>	<small>TEMPS IMPARTI / TARGET TIME</small>	
ES/SS	e1	"Corcieux"	20,00 km	42,39 km/h	00h55min

DISTANCE		DIRECTIONS	INFORMATIONS	DISTANCE DEGRESSIVE
TOTALE	PARTIELLE			
1,87	0,65		S.I. / N.I.	18,13 36,83
2,01	0,14	<div style="border: 1px solid black; padding: 2px; display: inline-block; margin-bottom: 5px;">5</div>  <div style="text-align: right; margin-top: 5px;"> <small>PK 20</small>  </div>	S.I. / N.I.	17,99 36,69
2,53	0,52	<div style="border: 1px solid black; padding: 2px; display: inline-block; margin-bottom: 5px;">6</div>  <div style="text-align: right; margin-top: 5px;"> <small>PK 25</small>  </div>	<div style="border: 1px solid black; padding: 5px; display: inline-block;"> Yvoux  </div>	17,47 36,17
2,78	0,25	<div style="border: 1px solid black; padding: 2px; display: inline-block; margin-bottom: 5px;">7</div>  <div style="text-align: right; margin-top: 5px;"> <small>PK 28</small>  </div>	 <p style="text-align: center; color: green; font-size: small;">ROUTE DE LA CARRIERE</p> <p style="text-align: center;">et SRP / and FMR</p>	17,22 35,92
4,02	1,24	<div style="border: 1px solid black; padding: 2px; display: inline-block; margin-bottom: 5px;">8</div>  <div style="text-align: right; margin-top: 5px;"> <small>PK 40</small>  </div>	<div style="border: 2px solid blue; padding: 5px; display: inline-block; background-color: white;"> <p style="text-align: center; margin: 0;">RUE DES CHAMPS THOMAS</p> </div>	15,98 34,68

Assistance interdite sur l'ensemble du parcours / Assistance forbidden on the whole course

1er e-RVGE

CH	e1	Avant ES e1 / Before SS e1 "Corcieux"	SECTION	DISTANCE	PAGE 17
CH	e1A	Regroupement & Recharge IN	1	38,70 km	
EPREUVE SPECIALE / SPECIAL STAGE			<small>VITESSE MOYENNE / AVERAGE SPEED</small>	<small>TEMPS IMPARTI / TARGET TIME</small>	
ES/SS	e1	"Corcieux"	20,00 km	42,39 km/h	00h55min

DISTANCE		DIRECTIONS	INFORMATIONS	DISTANCE DEGRESSIVE
TOTALE	PARTIELLE			
4,05	0,03			15,95 34,65
4,22	0,17		S.I. / N.I.	15,78 34,48
4,43	0,21		S.I. / N.I.	15,57
4,48	0,05		<p style="text-align: center; color: red;">!!</p> Séparateurs devant Fontaine / Dividers in front of the fountain	15,52 34,22
4,54	0,06			15,46 34,16

Assistance interdite sur l'ensemble du parcours / Assistance forbidden on the whole course

1er e-RVGE



CH	e1	Avant ES e1 / Before SS e1 "Corcieux"	SECTION	DISTANCE	PAGE 18
CH	e1A	Regroupement & Recharge IN	1	38,70 km	
EPREUVE SPECIALE / SPECIAL STAGE			VITESSE MOYENNE / AVERAGE SPEED	TEMPS IMPARTI / TARGET TIME	
ES/SS	e1	"Corcieux"	20,00 km	42,39 km/h	00h55min

DISTANCE		DIRECTIONS	INFORMATIONS	DISTANCE DEGRESSIVE
TOTALE	PARTIELLE			
4,69	0,15		<p><i>La Naye</i></p> <p><i>La Fortune</i></p>	<p>15,31</p> <p>34,01</p>
7,61	2,92		<p><i>Le Neuf Pré</i></p>	<p>12,39</p> <p>31,09</p>
7,66	0,05		<p><i>Houdry</i></p> <p><i>Monument Georges</i></p> <p><i>Le Neuf Pré</i></p>	<p>12,34</p> <p>31,04</p>
8,12	0,46		<p>!!!</p> <p>S.I. / N.I.</p>	<p>11,88</p> <p>30,58</p>
8,16	0,04		<p>S.I. / N.I.</p>	<p>11,84</p> <p>30,54</p>

Assistance interdite sur l'ensemble du parcours / Assistance forbidden on the whole course

1er e-RVGE

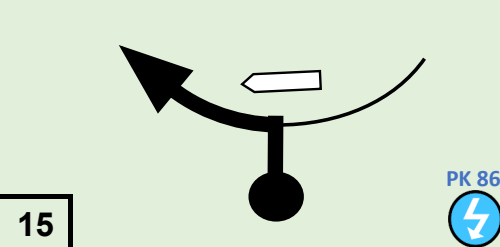
CH	e1	Avant ES e1 / Before SS e1 "Corcieux"	SECTION	DISTANCE	PAGE 19
CH	e1A	Regroupement & Recharge IN	1	38,70 km	
EPREUVE SPECIALE / SPECIAL STAGE			VITESSE MOYENNE / AVERAGE SPEED	TEMPS IMPARTI / TARGET TIME	
ES/SS	e1	"Corcieux"	20,00 km	42,39 km/h	00h55min

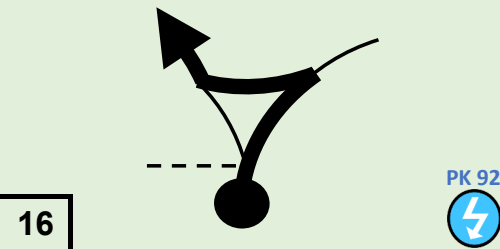
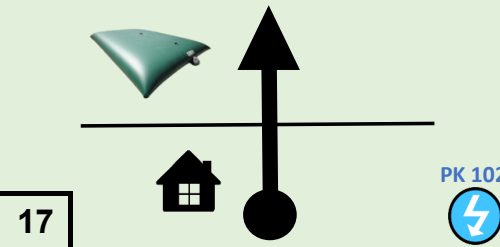
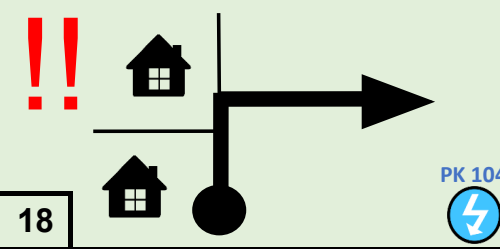
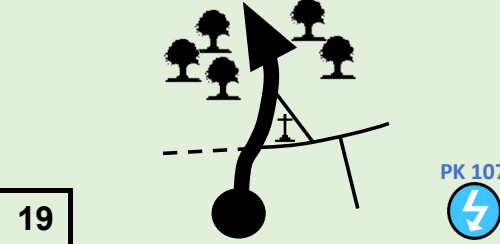
DISTANCE		DIRECTIONS	INFORMATIONS	DISTANCE DEGRESSIVE
TOTALE	PARTIELLE			
8,56	0,40			11,44 30,14
9,16	0,60		S.I. / N.I.	10,84 29,54
10,24	1,08		S.I. / N.I.	9,76 28,46
10,44	0,20		S.I. / N.I.	9,56 28,26
10,69	0,25		S.I. / N.I.	9,31 28,01

Assistance interdite sur l'ensemble du parcours / Assistance forbidden on the whole course

1er e-RVGE



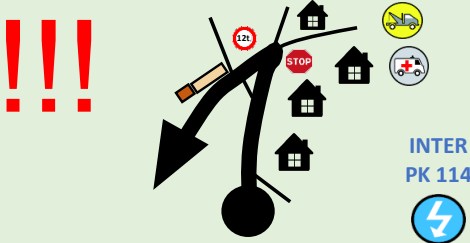
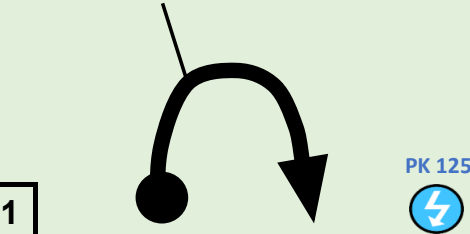
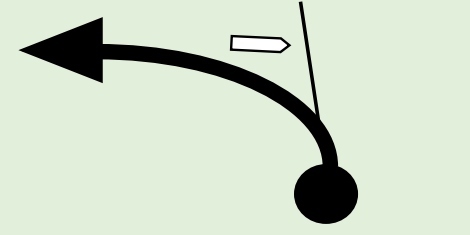
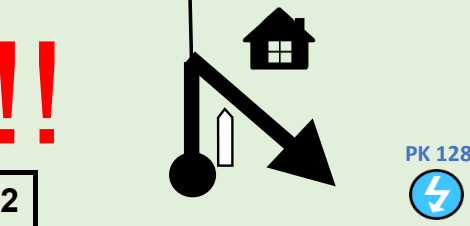



CH	e1	Avant ES e1 / Before SS e1 "Corcieux"	SECTION 1	DISTANCE 38,70 km	PAGE 20
CH	e1A	Regroupement & Recharge IN			
EPREUVE SPECIALE / SPECIAL STAGE			<small>VITESSE MOYENNE / AVERAGE SPEED</small> 42,39 km/h	<small>TEMPS IMPARTI / TARGET TIME</small> 00h55min	
ES/SS	e1	"Corcieux" 20,00 km			

DISTANCE		DIRECTIONS	INFORMATIONS	DISTANCE DEGRESSIVE
TOTALE	PARTIELLE			
11,44	0,75	 <p style="text-align: right; font-size: small;">INTER PK 114</p>	<div style="border: 1px solid black; padding: 2px; margin-bottom: 5px;"><i>La Cuisine des Arrentès</i></div> <div style="border: 2px solid brown; padding: 5px; text-align: center; background-color: #8B4513; color: white;"> RESTAURANT -----BAR----- </div>	8,56
11,58	0,14	<div style="border: 1px solid black; padding: 2px; margin-bottom: 5px; background-color: yellow;">D31</div> <div style="border: 2px solid black; padding: 5px; text-align: center; background-color: white; color: black;"> ARRENTÈS- DE-CORCIEUX </div>	SRP / FMR D31	8,42
20				27,26
12,54	0,96	 <p style="text-align: right; font-size: small;">PK 125</p>	S.I. / N.I.	7,46
21				26,16
12,78	0,24		<div style="border: 1px solid black; padding: 2px; margin-bottom: 5px; background-color: #D3D3D3;">C109</div> <div style="border: 1px solid black; padding: 5px; text-align: center;"> La Charmelle 0.3 </div>	7,22
22				25,92
12,84	0,06	 <p style="text-align: right; font-size: small;">PK 128</p>	<div style="border: 1px solid black; padding: 2px; margin-bottom: 5px; background-color: #D3D3D3;">C109</div> <div style="border: 1px solid black; padding: 5px; text-align: center;"> 0.3 La Charmelle </div>	7,16
22				25,86

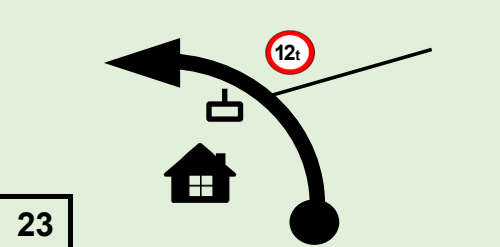
Assistance interdite sur l'ensemble du parcours / Assistance forbidden on the whole course

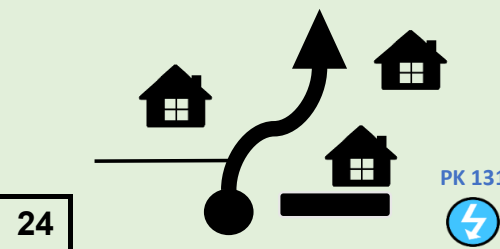
1er e-RVGE

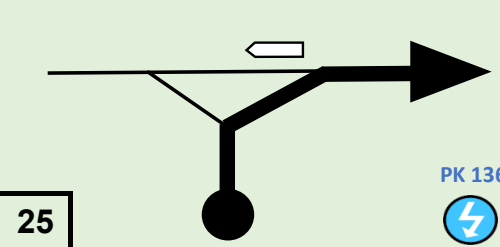

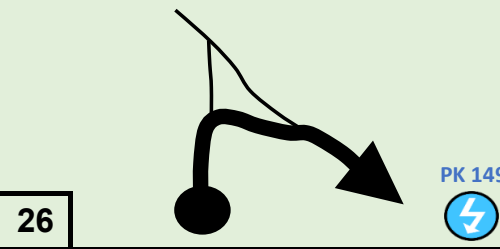
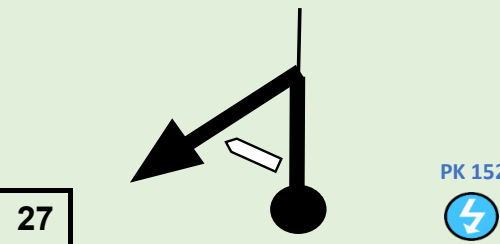
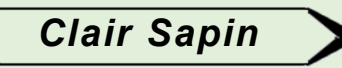



CH	e1	Avant ES e1 / Before SS e1 "Corcieux"	SECTION	DISTANCE	PAGE 21
CH	e1A	Regroupement & Recharge IN	1	38,70 km	
EPREUVE SPECIALE / SPECIAL STAGE			VITESSE MOYENNE / AVERAGE SPEED	TEMPS IMPARTI / TARGET TIME	
ES/SS	e1	"Corcieux" 20,00 km	42,39 km/h	00h55min	

DISTANCE		DIRECTIONS	INFORMATIONS	DISTANCE DEGRESSIVE
TOTALE	PARTIELLE			
12,91	0,07	 23	 7,09 25,79	7,09 25,79
13,14	0,23	 24	 6,86 25,56	6,86 25,56
13,58	0,44	 25	 6,42 25,12	6,42 25,12
14,94	1,36	 26	<p style="text-align: center;">S.I. / N.I.</p> 5,06 23,76	5,06 23,76
15,24	0,30	 27	 4,76 23,46	4,76 23,46

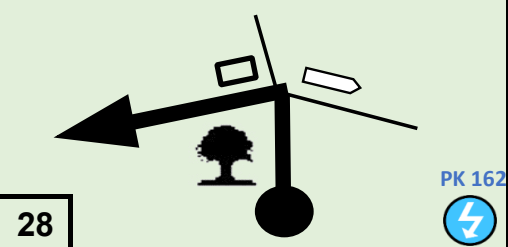
Assistance interdite sur l'ensemble du parcours / Assistance forbidden on the whole course

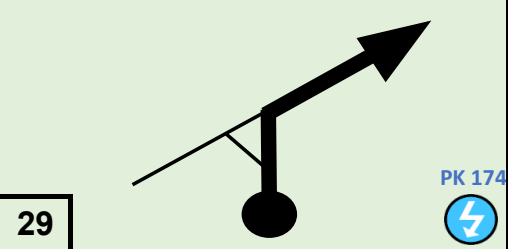
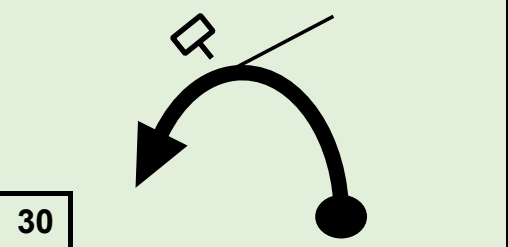
1er e-RVGE

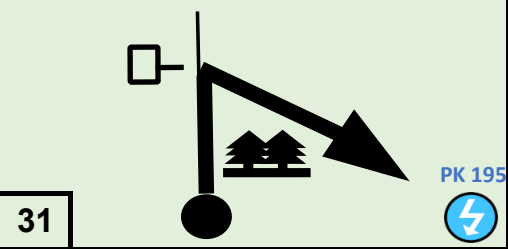
CH	e1	Avant ES e1 / Before SS e1 "Corcieux"	SECTION	DISTANCE	PAGE 22
CH	e1A	Regroupement & Recharge IN	1	38,70 km	
EPREUVE SPECIALE / SPECIAL STAGE			VITESSE MOYENNE / AVERAGE SPEED	TEMPS IMPARTI / TARGET TIME	
ES/SS	e1	"Corcieux"	20,00 km	42,39 km/h	00h55min

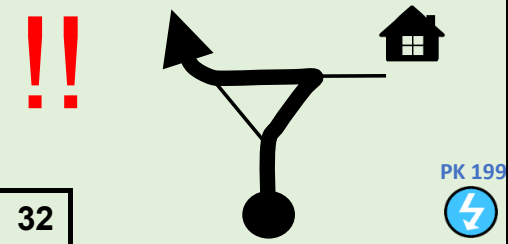
DISTANCE		DIRECTIONS	INFORMATIONS	DISTANCE DEGRESSIVE
TOTALE	PARTIELLE			
16,23	0,99			3,77
				22,47
17,39	1,16		S.I. / N.I.	
			21,31	2,61
17,97	0,58			
			20,73	2,03
19,51	1,54			
			19,19	0,49
19,94	0,43		S.I. / N.I.	
			18,76	0,06

Assistance interdite sur l'ensemble du parcours / Assistance forbidden on the whole course

1er e-RVGE



CH	e1	Avant ES e1 / Before SS e1 "Corcieux"	SECTION 1	DISTANCE 38,70 km	PAGE 23
CH	e1A	Regroupement & Recharge IN			
EPREUVE SPECIALE / SPECIAL STAGE			<small>VITESSE MOYENNE / AVERAGE SPEED</small> 42,39 km/h	<small>TEMPS IMPARTI / TARGET TIME</small> 00h55min	
ES/SS	e1	"Corcieux"	20,00 km		

DISTANCE		DIRECTIONS	INFORMATIONS	DISTANCE DEGRESSIVE
TOTALE	PARTIELLE			
20,00	0,06		<p>ARRIVEE / FINISH "CORCIEUX" ES / SS e1</p> <p>Au chemin à droite / At the path on the right</p> <div style="border: 1px solid black; padding: 5px; width: fit-content; margin: 10px auto;"> N 48° 9'12.0" E 6°52'51.6" </div>	<p style="color: red; font-weight: bold;">0,00</p> <p style="text-align: right;">18,70</p>
20,24	0,24		<p style="color: red; font-size: 2em; font-weight: bold;">!!!</p> <p style="color: red; font-weight: bold;">RALENTISSEUR / DECELERATOR</p>	<p style="text-align: right;">18,46</p>
20,69	0,45		<p>STOP POINT STOP "CORCIEUX" ES / SS e1</p> <p>Au croisement / At the crossroad</p> <div style="border: 1px solid black; padding: 5px; width: fit-content; margin: 10px auto;"> N 48° 9'29.3" E 6°52'32.8" </div> <div style="text-align: right; margin-top: 10px;"> </div>	<p style="text-align: right;">18,01</p>
21,32	0,63		<p>S.I. / N.I.</p>	<p style="text-align: right;">17,38</p>
21,53	0,21		<p>S.I. / N.I.</p>	<p style="text-align: right;">17,17</p>

Assistance interdite sur l'ensemble du parcours / Assistance forbidden on the whole course

1er e-RVGE

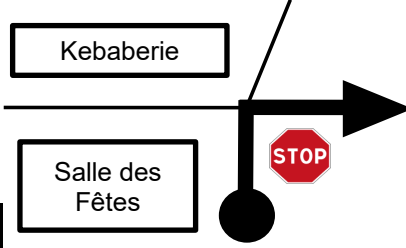
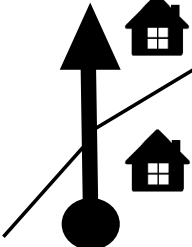
CH	e1	Avant ES e1 / Before SS e1 "Corcieux"	SECTION 1	DISTANCE 38,70 km	PAGE 24
CH	e1A	Regroupement & Recharge IN			
EPREUVE SPECIALE / SPECIAL STAGE			VITESSE MOYENNE / AVERAGE SPEED 42,39 km/h	TEMPS IMPARTI / TARGET TIME 00h55min	
ES/SS					

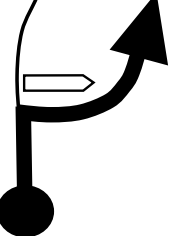
DISTANCE		DIRECTIONS	INFORMATIONS	DISTANCE DEGRESSIVE
TOTALE	PARTIELLE			
22,23	0,70		S.I. / N.I.	16,47
22,38	0,15	<div style="border: 1px solid black; padding: 2px; display: inline-block;">Kebaberie</div> 	S.I. / N.I.	16,32
		38		
22,55	0,17		S.I. / N.I.	16,15
		39		
23,39	0,84	<div style="border: 1px solid black; padding: 2px; display: inline-block; background-color: yellow;">D60</div> <div style="border: 1px solid black; padding: 5px; display: inline-block;">CORCIEUX</div> 	SRP / FMR D60	15,31
		40		
23,75	0,36	 	<div style="border: 1px solid black; padding: 2px; display: inline-block; background-color: yellow;">D86</div> <div style="border: 1px solid black; padding: 2px; display: inline-block; margin-bottom: 5px;"><i>Bellegoutte</i></div> <div style="border: 1px solid black; padding: 2px; display: inline-block;"><i>Rambaville</i></div>	14,95
		41		

1er e-RVGE

CH	e1	Avant ES e1 / Before SS e1 "Corcieux"	SECTION 1	DISTANCE 38,70 km	PAGE 25
CH	e1A	Regroupement & Recharge IN			
EPREUVE SPECIALE / SPECIAL STAGE			VITESSE MOYENNE / AVERAGE SPEED	TEMPS IMPARTI / TARGET TIME	
ES/SS			42,39 km/h	00h55min	

DISTANCE		DIRECTIONS	INFORMATIONS	DISTANCE DEGRESSIVE
TOTALE	PARTIELLE			
24,03	0,28	<div style="border: 1px solid black; padding: 5px; display: inline-block;">42</div>	S.I. et SRP / N.I. and FMR	14,67
24,13	0,10	<div style="border: 1px solid black; padding: 5px; display: inline-block;">43</div>	Rambaville	14,57
25,32	1,19	<div style="border: 1px solid black; padding: 5px; display: inline-block;">44</div>	La Moine Devant Varimont	13,38
25,88	0,56	<div style="border: 1px solid black; padding: 5px; display: inline-block;">45</div>	SRP / FMR D86	12,82
26,18	0,30	<div style="border: 1px solid black; padding: 5px; display: inline-block;">46</div>	GÉRARDMER 10 et SRP / and FMR D8	12,52

1er e-RVGE

CH	e1	Avant ES e1 / Before SS e1 "Corcieux"	SECTION 1	DISTANCE 38,70 km	PAGE 26
CH	e1A	Regroupement & Recharge IN			
EPREUVE SPECIALE / SPECIAL STAGE			VITESSE MOYENNE / AVERAGE SPEED	TEMPS IMPARTI / TARGET TIME	
ES/SS			42,39 km/h	00h55min	

DISTANCE		DIRECTIONS	INFORMATIONS	DISTANCE DEGRESSIVE
TOTALE	PARTIELLE			
34,42	8,24	<div style="border: 1px solid black; padding: 5px; display: inline-block;">47</div>	<div style="text-align: center; margin-bottom: 5px;">D417</div> <div style="border: 1px solid black; padding: 5px; margin-bottom: 5px; background-color: #90EE90; display: flex; justify-content: space-between;">ÉPINAL 44</div> <div style="border: 1px solid black; padding: 5px; margin-bottom: 5px; display: flex; justify-content: space-between;">GÉRARDMER 3</div>	4,28
35,05	0,63	<div style="border: 1px solid black; padding: 5px; display: inline-block;">48</div>	<div style="text-align: center; margin-bottom: 5px;">D417</div> <div style="border: 1px solid black; padding: 5px; margin-bottom: 5px; background-color: #90EE90; display: flex; justify-content: space-between;">ÉPINAL</div> <div style="border: 1px solid black; padding: 5px; margin-bottom: 5px; display: flex; justify-content: space-between;">GÉRARDMER - <i>CENTRE</i></div>	3,65
35,56	0,51	<div style="border: 1px solid black; padding: 5px; display: inline-block;">49</div> <div style="border: 2px solid red; padding: 5px; text-align: center; margin: 10px auto; width: 150px;">D417 GÉRARDMER</div>	SRP / FMR D417	3,14
36,30	0,74	<div style="border: 1px solid black; padding: 5px; display: inline-block;">50</div>	<div style="text-align: center; margin-bottom: 5px;">D417</div> <div style="border: 1px solid black; padding: 5px; margin-bottom: 5px; background-color: #90EE90; display: flex; justify-content: space-between;">ÉPINAL</div> <div style="border: 1px solid black; padding: 5px; margin-bottom: 5px; display: flex; justify-content: space-between;">CENTRE VILLE</div>	2,40
36,44	0,14	<div style="border: 1px solid black; padding: 5px; display: inline-block;">50</div>	<div style="text-align: center; margin-bottom: 5px;">D417</div> <div style="border: 1px solid black; padding: 5px; margin-bottom: 5px; background-color: #90EE90; display: flex; justify-content: space-between;">ÉPINAL</div> <div style="border: 1px solid black; padding: 5px; margin-bottom: 5px; display: flex; justify-content: space-between;">REMIREMONT LA BRESSE</div> <div style="border: 1px solid black; padding: 5px; margin-bottom: 5px; display: flex; justify-content: space-between;"><i>Coteau des XETTES</i> <i>Halle des Sports</i></div>	2,26

Assistance interdite sur l'ensemble du parcours / Assistance forbidden on the whole course

1er e-RVGE

CH	e1	Avant ES e1 / Before SS e1 "Corcieux"	SECTION 1	DISTANCE 38,70 km	PAGE 27
CH	e1A	Regroupement & Recharge IN			
EPREUVE SPECIALE / SPECIAL STAGE			VITESSE MOYENNE / AVERAGE SPEED	TEMPS IMPARTI / TARGET TIME	
ES/SS			42,39 km/h	00h55min	

DISTANCE		DIRECTIONS	INFORMATIONS	DISTANCE DEGRESSIVE
TOTALE	PARTIELLE			
37,91	1,47		S.I. / N.I.	0,79
38,16	0,25		<p>LA BRESSE</p> <p>CENTRE VILLE</p> <p> Hôpital</p>	0,54
38,32	0,16		S.I. / N.I.	0,38
38,40	0,08		<p>LA BRESSE</p> <p>La Rayée</p> <p>LA BRESSE</p> <p>LA RAYÉE RAMBERCHAMP</p>	0,30
38,51	0,11		<p>S.I. / N.I.</p> <p>ADAC OPEL 28 Bis</p>	0,19

Assistance interdite sur l'ensemble du parcours / Assistance forbidden on the whole course

1er e-RVGE					
CH	e1	Avant ES e1 / Before SS e1 "Corcieux"	SECTION	DISTANCE	PAGE
CH	e1A	Regroupement & Recharge IN	1	38,70 km	
EPREUVE SPECIALE / SPECIAL STAGE			VITESSE MOYENNE / AVERAGE SPEED	TEMPS IMPARTI / TARGET TIME	28
ES/SS			42,39 km/h	00h55min	
DISTANCE		DIRECTIONS	INFORMATIONS		DISTANCE DEGRESSIVE
TOTALE	PARTIELLE				
38,64	0,13				0,06
38,70	0,06		<p>CH e1A Regroupement & Recharge IN</p>		0,00
		54	N 48°04'13.1" E 6°52'07.9"		

SECTION 1 | CH e1A

C.H. e1A Regroupement & Recharge IN

N 48°04'13.1" E 6°52'07.9"

1er e-RVGE

CH	e1	Avant ES e1 / Before SS e1 "Corcieux"	SECTION 1	DISTANCE 38,77 km	PAGE 28 BIS
CH	e1A	Regroupement & Recharge IN			
EPREUVE SPECIALE / SPECIAL STAGE			VITESSE MOYENNE / AVERAGE SPEED	TEMPS IMPARTI / TARGET TIME	
ES/SS			42,29 km/h	00h55min	

DISTANCE		DIRECTIONS	INFORMATIONS	DISTANCE DEGRESSIVE
TOTALE	PARTIELLE			
38,64	0,13			0,16
38,71	0,07		S.I. / N.I.	0,09
38,80	0,09			0,00

54

C.H. e1A Regroupement & Recharge IN





N 48° 4'12.2" E 6°52'4.7"



SECTION 1 CH e1A









1er e-RVGE

CH	e1A	Regroupement & Recharge IN	SECTION 1	DISTANCE 0,00 km	PAGE 29 BIS
CH	e1B	Regroupement OUT - Assistance IN			
EPREUVE SPECIALE / SPECIAL STAGE			<small>VITESSE MOYENNE / AVERAGE SPEED</small> -	<small>TEMPS IMPARTI / TARGET TIME</small> 02h57min	
ES/SS					

DISTANCE		DIRECTIONS	INFORMATIONS	DISTANCE DEGRESSIVE
TOTALE	PARTIELLE			
0,00	0,00	PARK 	<u>Regroupement & Recharge IN</u>	0,00
0,00	0,00	 PARK 	 <u>CH e1B</u> Regroupement OUT - Assistance IN  N 48°4'20.1" E 6°52'23.6"	0,00
		1		

1er e-RVGE





CH	e1B	Regroupement OUT - Assistance IN	SECTION 2	DISTANCE 0,00 km	PAGE 30 BIS
CH	e1C	Assistance OUT			
EPREUVE SPECIALE / SPECIAL STAGE			VITESSE MOYENNE / AVERAGE SPEED	TEMPS IMPARTI / TARGET TIME	
ES/SS			-	01h15min	

DISTANCE		DIRECTIONS	INFORMATIONS	DISTANCE DEGRESSIVE
TOTALE	PARTIELLE			
0,00	0,00	 PARK 	 <u>CH e1B</u> Regroupement OUT - Assistance IN <div style="border: 1px solid black; padding: 2px; margin-top: 10px;">  N 48°4'20.1" E 6°52'23.6" </div>	0,00
0,00	0,00	 PARK 	 <u>CH e1C</u> Assistance OUT <div style="border: 1px solid black; padding: 2px; margin-top: 10px;">  N 48°4'20.1" E 6°52'23.6" </div>	0,00

1

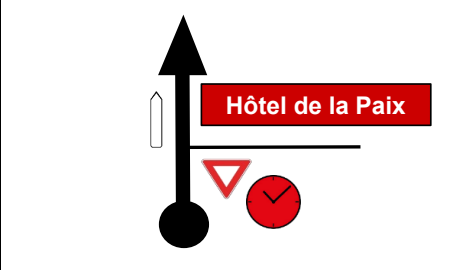
1er e-RVGE

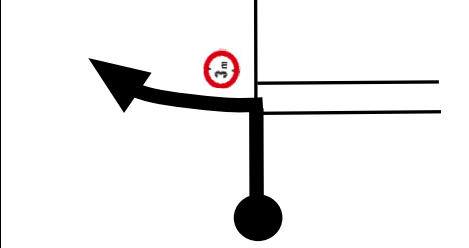

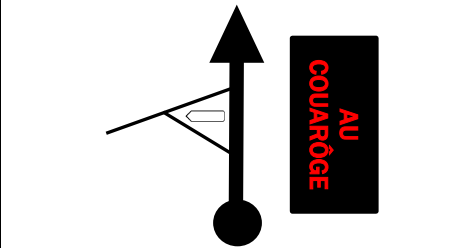
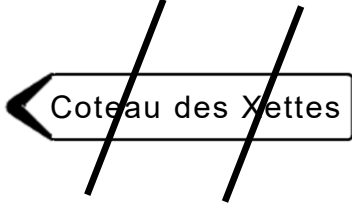
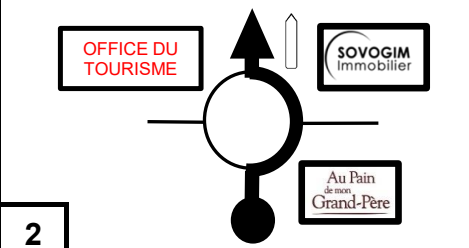
CH	e1C	Assistance OUT	SECTION	DISTANCE	PAGE
CH	3	Avant ES 3 / Before SS 3 "Corcieux"	2	24,02 km	
EPREUVE SPECIALE / SPECIAL STAGE			VITESSE MOYENNE / AVERAGE SPEED	TEMPS IMPARTI / TARGET TIME	31 BIS
ES/SS			41,18 km/h	00h35mn	

DISTANCE		DIRECTIONS	INFORMATIONS	DISTANCE
TOTALE	PARTIELLE			DEGRESSIVE
0,00	0,00		 <p style="text-align: center;"><u>CH e1C</u> Assistance OUT</p> <div style="border: 1px solid black; padding: 5px; width: fit-content; margin: 10px auto;">  N 48° 4'15.4" E 6°52'1.2" </div>	24,02
0,08	0,08		S.I. / N.I.	23,94
0,19	0,11	<div style="border: 1px solid black; padding: 2px; width: fit-content; margin: 0 auto;"> 6 Bar à Vins Restaurant </div> 	S.I. / N.I.	23,83
		1		
0,43	0,24			23,59
0,51	0,08		<p style="text-align: center;">puis reprendre / then resume</p> <p style="text-align: center; color: red; font-weight: bold;">Case 2 page 32</p> <p style="text-align: center;">à / at 0,23 km</p>	23,51
		2		

Assistance interdite sur l'ensemble du parcours / Assistance forbidden on the whole course

1er e-RVGE

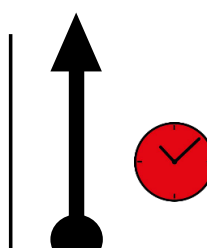
CH	e1A	Regroupement & Recharge IN	SECTION 2	DISTANCE 0,58 km	PAGE 29
CH	-	-			
EPREUVE SPECIALE / SPECIAL STAGE			VITESSE MOYENNE / AVERAGE SPEED	TEMPS IMPARTI / TARGET TIME	
ES/SS					

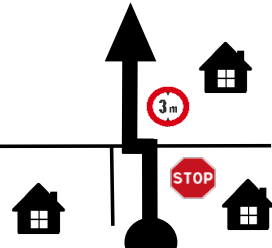
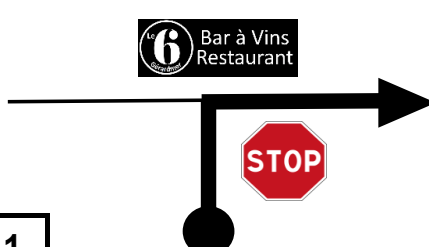
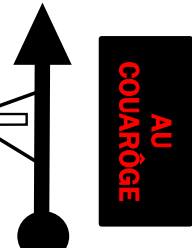
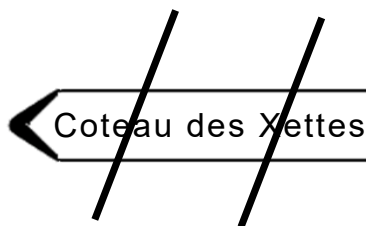
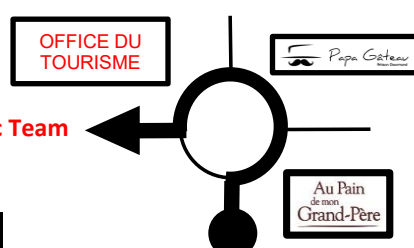



DISTANCE		DIRECTIONS	INFORMATIONS	DISTANCE DEGRESSIVE
TOTALE	PARTIELLE			
0,00	0,00		 <p>CH e1A Regroupement & Recharge IN</p> <div style="border: 1px solid black; padding: 5px; width: fit-content;">  <p>N 48°04'13.1" E 6°52'07.9"</p> </div>	0,58
0,06	0,06		S.I. / N.I.	0,52
0,17	0,11	 <div style="border: 1px solid black; padding: 2px; width: 20px; text-align: center; margin-left: 20px;">1</div>	S.I. et SRP / N.I. and FMR	0,41
0,41	0,24	 <div style="border: 1px solid black; padding: 2px; width: 20px; text-align: center; margin-left: 20px;">3</div>		0,17
0,49	0,08	 <div style="border: 1px solid black; padding: 2px; width: 20px; text-align: center; margin-left: 20px;">4</div>	S.I. / N.I.	0,09

Assistance interdite sur l'ensemble du parcours / Assistance forbidden on the whole course

1er e-RVGE						
CH	e1A	Regroupement & Recharge IN		SECTION	DISTANCE	PAGE
CH	-	-		1	0,58 km	
EPREUVE SPECIALE / SPECIAL STAGE				VITESSE MOYENNE / AVERAGE SPEED	TEMPS IMPARTI / TARGET TIME	30
ES/SS						
DISTANCE		DIRECTIONS	INFORMATIONS	DISTANCE DEGRESSIVE		
TOTALE	PARTIELLE					
0,58	0,09		<u>Regroupement & Recharge IN</u>	0,00		









1er e-RVGE

CH	-	-	SECTION 1	DISTANCE 0,00 km	PAGE 31
CH	e1B	Regroupement OUT - Assistance IN			
EPREUVE SPECIALE / SPECIAL STAGE			VITESSE MOYENNE / AVERAGE SPEED -	TEMPS IMPARTI / TARGET TIME 02h57min	
ES/SS					

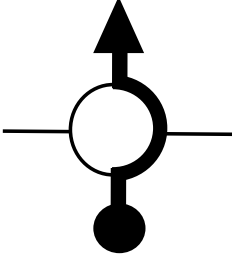
DISTANCE		DIRECTIONS	INFORMATIONS	DISTANCE DEGRESSIVE
TOTALE	PARTIELLE			
0,00	0,00	<p>PARC</p> 	<p><u>Regroupement & Recharge IN</u></p>	0,00
0,00	0,00	<p>PARC</p>  <p>1</p>	<p><u>CH e1B</u></p> <p>Regroupement OUT - Assistance IN - P. de la Prairie</p>  <div style="border: 1px solid black; padding: 5px; width: fit-content; margin-top: 10px;">  <p>N 48°4'20.1" E 6°52'23.6"</p> </div>	0,00

1er e-RVGE

CH	e1B	Regroupement OUT - Assistance IN	SECTION 2	DISTANCE 0,58 km	PAGE 32
CH	e1C	Assistance OUT			
EPREUVE SPECIALE / SPECIAL STAGE			VITESSE MOYENNE / AVERAGE SPEED -	TEMPS IMPARTI / TARGET TIME 01h15min	
ES/SS					

DISTANCE		DIRECTIONS	INFORMATIONS	DISTANCE DEGRESSIVE
TOTALE	PARTIELLE			
0,00	0,00	 <div style="border: 1px solid black; padding: 5px; margin: 10px auto; width: 150px;"> <p style="text-align: center;">PARC</p> <p style="text-align: center;">TROPHÉE</p> <h1 style="text-align: center; margin: 0;">A290</h1> <p style="text-align: center;">RALLYE</p> </div>	<p>CH e1B</p> <p>Regroupement OUT - Assistance IN - P. de la Prairie</p> <div style="border: 1px solid black; padding: 5px; margin-top: 10px; width: fit-content;"> <p>N 48°4'20.1" E 6°52'23.6"</p> </div>	0,58
0,09	0,09	 <div style="border: 1px solid black; padding: 5px; margin: 10px auto; width: 100px;"> <p style="text-align: center;">Parc P. de la Prairie</p> </div> <div style="border: 1px solid black; padding: 2px; width: 20px; text-align: center; margin-top: 10px;">1</div>	S.I. / N.I.	0,49
0,29	0,20	<div style="border: 1px solid black; padding: 5px; margin: 10px auto; width: 40px; transform: rotate(-90deg);">LINVOSGES</div>  <div style="border: 1px solid black; padding: 2px; width: 20px; text-align: center; margin-top: 10px;">2</div>	S.I. / N.I.	0,29
0,50	0,21	  <div style="border: 1px solid black; padding: 5px; margin: 10px auto; width: 80px;">  <p style="text-align: center;">CAISSE D'ÉPARGNE</p> </div>	S.I. / N.I.	0,08
0,58	0,08	<div style="border: 1px solid black; padding: 5px; margin: 10px auto; width: 40px; transform: rotate(-90deg);">Cimetière</div>    <div style="border: 1px solid black; padding: 2px; width: 20px; text-align: center; margin-top: 10px;">3</div>	<p>CH e1C</p> <p>Assistance OUT</p> <div style="border: 1px solid black; padding: 5px; margin-top: 10px; width: fit-content;"> <p>N 48°4'28.0" E 6°52'43.1"</p> </div>	0,00



Assistance interdite sur l'ensemble du parcours / Assistance forbidden on the whole course

1er e-RVGE					
CH	e1B	Regroupement OUT - Assistance IN	SECTION	DISTANCE	PAGE
CH	e1C	Assistance OUT	2	0,58 km	
EPREUVE SPECIALE / SPECIAL STAGE			VITESSE MOYENNE / AVERAGE SPEED	TEMPS IMPARTI / TARGET TIME	33
ES/SS			-	01h15min	
DISTANCE		DIRECTIONS	INFORMATIONS	DISTANCE DEGRESSIVE	
TOTALE	PARTIELLE				

SECTION 2	CH e1C
-----------	--------

C.H. e1C Assistance OUT

 N 48°4'28.0" E 6°52'43.1"

1er e-RVGE

CH	e1C	Assistance OUT	SECTION	DISTANCE	PAGE 34
CH	3	Avant ES 3 / Before SS 3 "Corcieux"	2	22,96 km	
EPREUVE SPECIALE / SPECIAL STAGE			VITESSE MOYENNE / AVERAGE SPEED	TEMPS IMPARTI / TARGET TIME	
ES/SS			39,36 km/h	00h35min	

DISTANCE		DIRECTIONS	INFORMATIONS	DISTANCE DEGRESSIVE
TOTALE	PARTIELLE			
0,00	0,00		<p>CH e1C Service OUT</p> <div style="border: 1px solid black; padding: 2px; display: inline-block;"> N 48°4'28.0" E 6°52'43.1" </div>	22,96
0,07	0,07	<div style="border: 1px solid black; padding: 2px; display: inline-block; margin-bottom: 5px;">1</div>	<div style="border: 1px solid black; padding: 5px; display: inline-block; width: 100px;"> AUTRES DIRECTIONS </div>	22,89
0,28	0,21		<div style="border: 1px solid black; padding: 5px; display: inline-block; width: 100px;"> COLMAR </div> <div style="border: 1px solid black; padding: 5px; display: inline-block; width: 100px; margin-top: 5px;"> BRUYÈRES SAINT - DIÉ </div>	22,68
0,37	0,09	<div style="border: 1px solid black; padding: 2px; display: inline-block; margin-bottom: 5px;">2</div>	<div style="border: 1px solid black; padding: 5px; display: inline-block; width: 100px; margin-bottom: 5px; background-color: #90EE90;"> COLMAR </div> <div style="border: 1px solid black; padding: 5px; display: inline-block; width: 100px; margin-bottom: 5px;"> BRUYÈRES SAINT - DIÉ </div> <div style="border: 1px solid black; padding: 5px; display: inline-block; width: 100px;"> XONRUPT - LONGEMER </div>	22,59
0,55	0,18	<div style="border: 1px solid black; padding: 2px; display: inline-block; margin-bottom: 5px;">3</div>	<div style="border: 1px solid black; padding: 5px; display: inline-block; width: 100px; margin-bottom: 5px;"> BRUYERES SAINT - DIE </div> <div style="border: 1px solid black; padding: 5px; display: inline-block; width: 100px; margin-bottom: 5px;"> XONRUPT -LONGEMER </div> <div style="border: 1px solid black; padding: 5px; display: inline-block; width: 100px;"> COLMAR </div>	22,41

Assistance interdite sur l'ensemble du parcours / Assistance forbidden on the whole course

1er e-RVGE





CH	e1C	Assistance OUT	SECTION	DISTANCE	PAGE
CH	3	Avant ES 3 / Before SS 3 "Corcieux"	2	22,96 km	
EPREUVE SPECIALE / SPECIAL STAGE			VITESSE MOYENNE / AVERAGE SPEED	TEMPS IMPARTI / TARGET TIME	35
ES/SS			39,36 km/h	00h35min	

DISTANCE		DIRECTIONS	INFORMATIONS	DISTANCE DEGRESSIVE
TOTALE	PARTIELLE			
0,76	0,21		<p>D417</p> <p>COLMAR</p> <p>XONRUPT - LONGEMER</p> <p>BRUYERES SAINT - DIÉ</p>	22,20
0,89	0,13	<p>4</p>	<p>D423</p> <p>GRANGES ^S/ V. BRUYÈRES</p> <p>KICHOMPRE LE KERTOFF</p>	22,07
1,41	0,52	<p>5</p>	SRP / FMR D423	21,55
2,39	0,98	<p>6</p>	SRP / FMR D423	20,57
3,29	0,90	<p>7</p>	SRP / FMR D423	19,67

Assistance interdite sur l'ensemble du parcours / Assistance forbidden on the whole course

1er e-RVGE

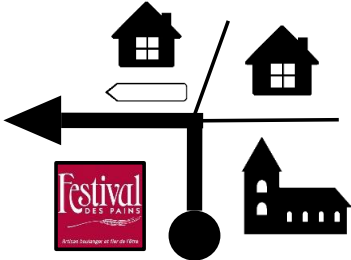







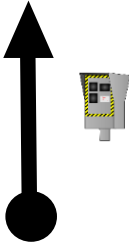

CH	e1C	Assistance OUT	SECTION 2	DISTANCE 22,96 km	PAGE 36
CH	3	Avant ES 3 / Before SS 3 "Corcieux"			
EPREUVE SPECIALE / SPECIAL STAGE			<small>VITESSE MOYENNE / AVERAGE SPEED</small> 39,36 km/h	<small>TEMPS IMPARTI / TARGET TIME</small> 00h35min	
ES/SS					

DISTANCE		DIRECTIONS	INFORMATIONS	DISTANCE DEGRESSIVE
TOTALE	PARTIELLE			
3,98	0,69	<div style="text-align: center;">  D423 <div style="border: 2px solid red; padding: 5px; display: inline-block;"> LE KERTOFF <i>Cne de GÉRARDMER</i> </div> </div>	SRP / FMR D423	18,98
		8		
4,62	0,64	<div style="text-align: center;">  D423 <div style="border: 1px solid black; padding: 5px; display: inline-block; text-decoration: line-through;"> LE KERTOFF </div> </div>	SRP / FMR D423	18,34
		9		
11,30	6,68	<div style="text-align: center;">  D423 <div style="border: 2px solid red; padding: 5px; display: inline-block;"> GRANGES ^s/ VOLOGNE <i>Cne de GRANGES-AUMONTZEY</i> </div> </div>	SRP / FMR D423	11,66
		10		
12,49	1,19	<div style="text-align: center;">  </div>	<div style="text-align: center;"> D423 <div style="border: 1px solid black; padding: 5px; display: inline-block;"> 3 AUMONTZEY 9 BRUYÈRES </div> et SRP / and FMR D423 </div>	10,47
		11		
13,68	1,19	<div style="text-align: center;">  D423 <div style="border: 1px solid black; padding: 5px; display: inline-block; text-decoration: line-through;"> GRANGES SUR VOLOGNE </div> </div>	SRP / FMR D423	9,28
		12		

Assistance interdite sur l'ensemble du parcours / Assistance forbidden on the whole course

1er e-RVGE

CH	e1C	Assistance OUT	SECTION 2	DISTANCE 22,96 km	PAGE 37
CH	3	Avant ES 3 / Before SS 3 "Corcieux"			
EPREUVE SPECIALE / SPECIAL STAGE			<small>VITESSE MOYENNE / AVERAGE SPEED</small> 39,36 km/h	<small>TEMPS IMPARTI / TARGET TIME</small> 00h35min	
ES/SS					

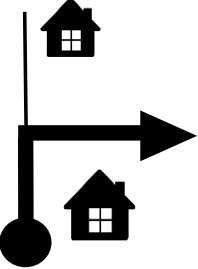
DISTANCE		DIRECTIONS	INFORMATIONS	DISTANCE DEGRESSIVE
TOTALE	PARTIELLE			
14,93	1,25	  13	SRP / FMR D423	8,03
15,19	0,26	 14	ATTENTION / WARNING RADAR SRP / FMR D423	7,77
15,71	0,52	   15	SRP / FMR D423	7,25
16,83	1,12	  16	SRP / FMR D423	6,13
17,42	0,59	    17	S.I. / N.I.	5,54

Assistance interdite sur l'ensemble du parcours / Assistance forbidden on the whole course

1er e-RVGE











CH	e1C	Assistance OUT	SECTION	DISTANCE	PAGE
CH	3	Avant ES 3 / Before SS 3 "Corcieux"	2	22,96 km	
EPREUVE SPECIALE / SPECIAL STAGE			VITESSE MOYENNE / AVERAGE SPEED	TEMPS IMPARTI / TARGET TIME	38
ES/SS			39,36 km/h	00h35min	

DISTANCE		DIRECTIONS	INFORMATIONS	DISTANCE DEGRESSIVE
TOTALE	PARTIELLE			
17,81	0,39	 18		5,15
18,11	0,30	 19		4,85
18,40	0,29	 20	S.I. / N.I.	4,56
18,82	0,42	 21		4,14
19,85	1,03	 22		3,11

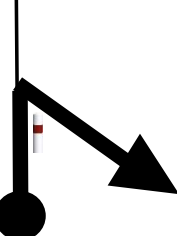
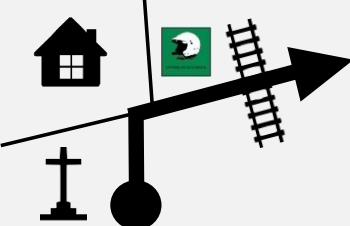
Assistance interdite sur l'ensemble du parcours / Assistance forbidden on the whole course

1er e-RVGE

CH	e1C	Assistance OUT	SECTION	DISTANCE	PAGE
CH	3	Avant ES 3 / Before SS 3 "Corcieux"	2	22,96 km	
EPREUVE SPECIALE / SPECIAL STAGE			VITESSE MOYENNE / AVERAGE SPEED	TEMPS IMPARTI / TARGET TIME	39
ES/SS			39,36 km/h	00h35min	

DISTANCE		DIRECTIONS	INFORMATIONS	DISTANCE DEGRESSIVE
TOTALE	PARTIELLE			
20,75	0,90	  23	SRP / FMR D81	2,21
21,91	1,16	  24	SRP / FMR D81	1,05
22,46	0,55	  25	S.I. / N.I.	0,50
22,94	0,48		 !!! VOIE FERREE ACTIVE / ACTIVE RAILWAY !!!	0,02
22,96	0,02	   26	 CH 3 Avant ES3 / Before SS3  N 48°12'20.5" E 6°48'25.6" 0,16 km avant Départ ES3 / before start of SS3 "Corcieux"	0,00

Assistance interdite sur l'ensemble du parcours / Assistance forbidden on the whole course

1er e-RVGE

EPREUVE SPECIALE / SPECIAL STAGE

SECTION

2

PAGE

40

ES/SS

3

"Corcieux"

20,00 km

1ère / 1st

A290

14h43

C.H. 3



N 48°12'20.5"
E 6°48'25.6"

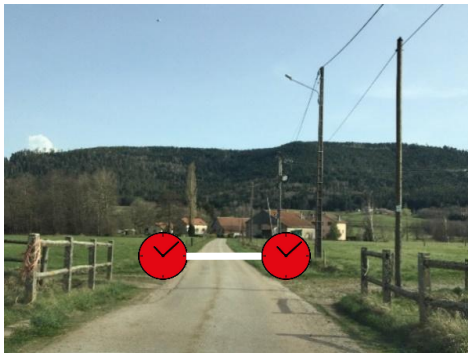

DEPART / START



N 48°12'16.3"
E 6°48'29.4"

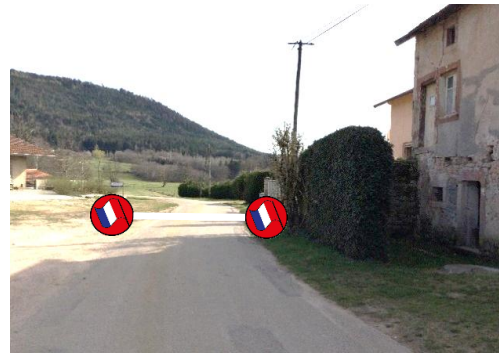

ARRIVEE / FINISH



N 48° 9'12.0"
E 6°52'51.6"



POINT STOP



N 48° 9'29.3"
E 6°52'32.8"



Fermeture de la route à / Road closure at :

1ère/1st car :

08h00 - 23h00

14h43

41



ES 3 - ES 6 Corcieux : 20 km
Samedi 13 juin 2026
 ES 3: 12h04 - ES 6: 17h28
 Horaires sous réserve de modifications.

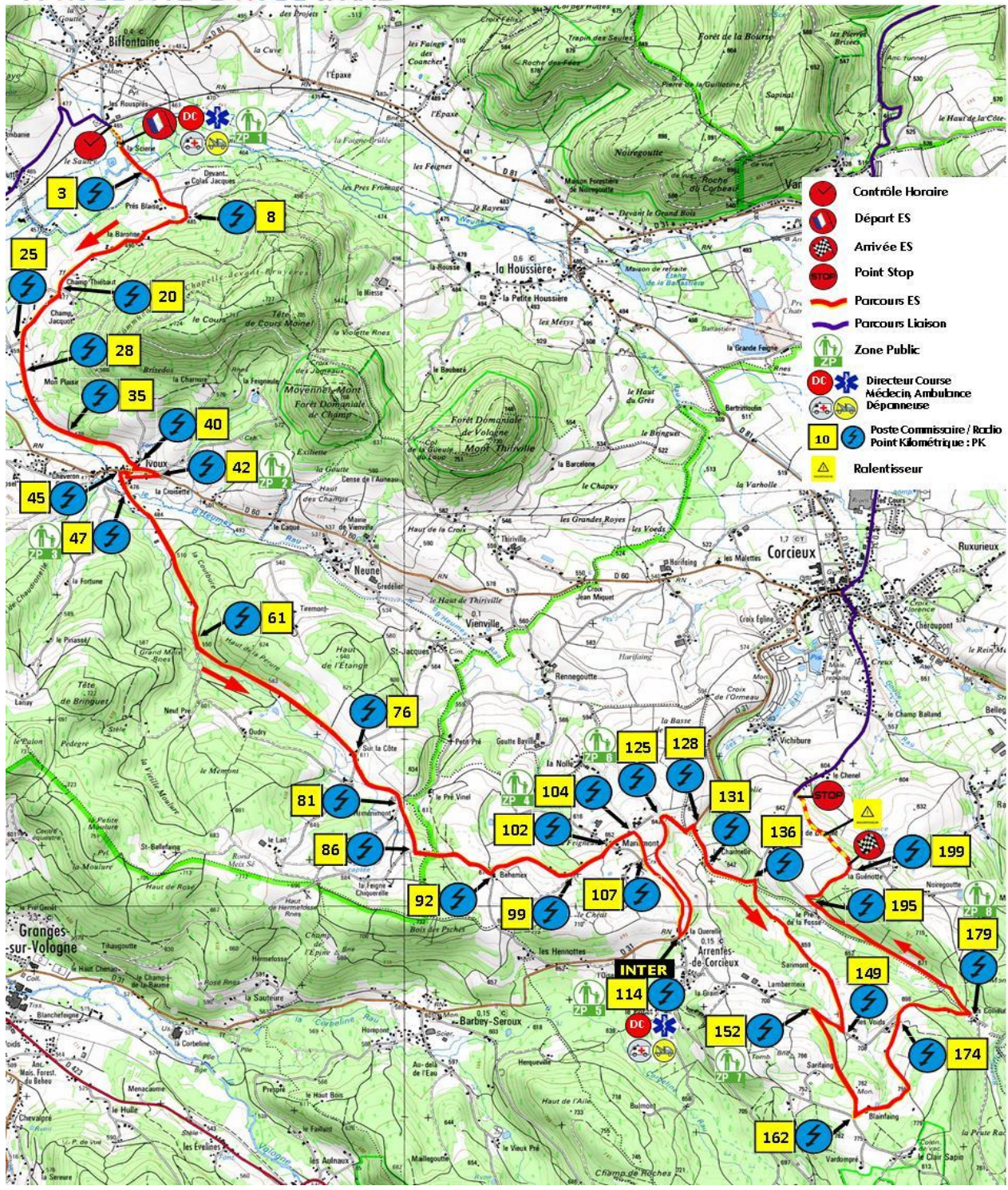

1er e-RVGE

CH	3	Avant ES 3 / Before SS 3 "Corcieux"	SECTION	DISTANCE	PAGE 42
CH	3A	Regroupement & Recharge IN	2	38,70 km	
EPREUVE SPECIALE / SPECIAL STAGE			VITESSE MOYENNE / AVERAGE SPEED	TEMPS IMPARTI / TARGET TIME	
ES/SS	3	"Corcieux"	20,00 km	42,39 km/h	00h55min

DISTANCE		DIRECTIONS	INFORMATIONS	DISTANCE DEGRESSIVE
TOTALE	PARTIELLE			
0,00	0,00	 1		20,00 38,70
0,52	0,52		S.I. / N.I.	19,48 38,18
0,58	0,06	 2	S.I. / N.I.	19,42 38,12
0,80	0,22	 3	S.I. / N.I.	19,20 37,90
1,22	0,42	 4	S.I. / N.I.	18,78 37,48

Assistance interdite sur l'ensemble du parcours / Assistance forbidden on the whole course

1er e-RVGE

CH	3	Avant ES 3 / Before SS 3 "Corcieux"	SECTION	DISTANCE	PAGE
CH	3A	Regroupement & Recharge IN	2	38,70 km	
EPREUVE SPECIALE / SPECIAL STAGE			VITESSE MOYENNE / AVERAGE SPEED	TEMPS IMPARTI / TARGET TIME	43
ES/SS	3	"Corcieux"	20,00 km	42,39 km/h	

DISTANCE		DIRECTIONS	INFORMATIONS	DISTANCE DEGRESSIVE
TOTALE	PARTIELLE			
1,87	0,65		S.I. / N.I.	18,13 36,83
2,01	0,14		S.I. / N.I.	17,99 36,69
2,53	0,52		Yvoux	17,47 36,17
2,78	0,25		ROUTE DE LA CARRIERE1266.. et SRP / and FMR	17,22 35,92
4,02	1,24		RUE DES CHAMPS THOMAS	15,98 34,68

Assistance interdite sur l'ensemble du parcours / Assistance forbidden on the whole course

1er e-RVGE

CH	3	Avant ES 3 / Before SS 3 "Corcieux"	SECTION	DISTANCE	PAGE
CH	3A	Regroupement & Recharge IN	2	38,70 km	
EPREUVE SPECIALE / SPECIAL STAGE			VITESSE MOYENNE / AVERAGE SPEED	TEMPS IMPARTI / TARGET TIME	44
ES/SS	3	"Corcieux"	20,00 km	42,39 km/h	

DISTANCE		DIRECTIONS	INFORMATIONS	DISTANCE DEGRESSIVE
TOTALE	PARTIELLE			
4,05	0,03			15,95 34,65
4,22	0,17		S.I. / N.I.	15,78 34,48
4,43	0,21		S.I. / N.I.	15,57
4,48	0,05		<p style="text-align: center;">Séparateurs devant Fontaine / Dividers in front of the fountain</p>	15,52 34,22
4,54	0,06			15,46 34,16

Assistance interdite sur l'ensemble du parcours / Assistance forbidden on the whole course

1er e-RVGE

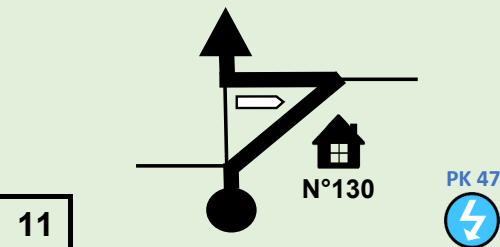
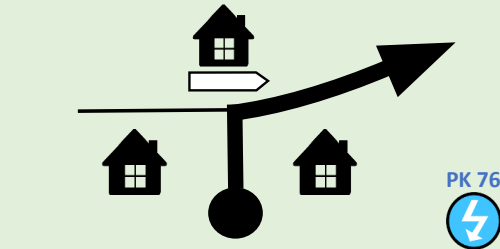
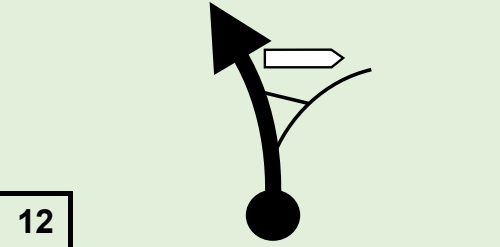
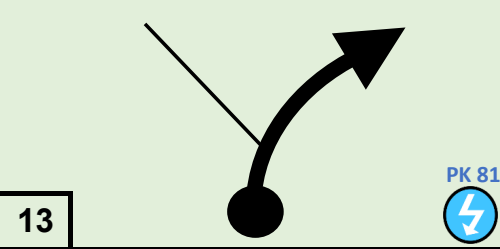
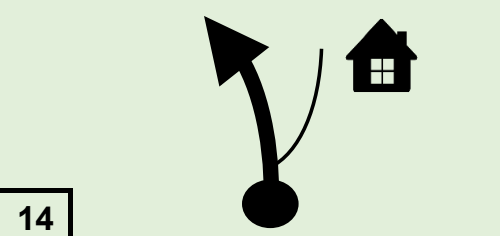

CH	3	Avant ES 3 / Before SS 3 "Corcieux"	SECTION	DISTANCE	PAGE 45
CH	3A	Regroupement & Recharge IN	2	38,70 km	
EPREUVE SPECIALE / SPECIAL STAGE			VITESSE MOYENNE / AVERAGE SPEED	TEMPS IMPARTI / TARGET TIME	
ES/SS	3	"Corcieux"	20,00 km	42,39 km/h	00h55min

DISTANCE		DIRECTIONS	INFORMATIONS	DISTANCE DEGRESSIVE
TOTALE	PARTIELLE			
4,69	0,15	<div style="border: 1px solid black; padding: 5px; display: inline-block;">11</div> 	<div style="border: 1px solid black; padding: 5px; display: inline-block; margin-bottom: 5px;">La Naye</div> <div style="border: 1px solid black; padding: 5px; display: inline-block;">La Fortune</div>	15,31 34,01
7,61	2,92	<div style="border: 1px solid black; padding: 5px; display: inline-block;">12</div> 	<div style="border: 1px solid black; padding: 5px; display: inline-block;">Le Neuf Pré</div>	12,39 31,09
7,66	0,05	<div style="border: 1px solid black; padding: 5px; display: inline-block;">12</div> 	<div style="border: 1px solid black; padding: 5px; display: inline-block; margin-bottom: 5px;">Houdry</div> <div style="border: 1px solid black; padding: 5px; display: inline-block; margin-bottom: 5px;">Monument Georges</div> <div style="border: 1px solid black; padding: 5px; display: inline-block;">Le Neuf Pré</div>	12,34 31,04
8,12	0,46	<div style="border: 1px solid black; padding: 5px; display: inline-block;">13</div> 	<div style="text-align: center; color: red; font-size: 2em;">!!!</div> <p style="text-align: center;">S.I. / N.I.</p>	11,88 30,58
8,16	0,04	<div style="border: 1px solid black; padding: 5px; display: inline-block;">14</div> 	<p style="text-align: center;">S.I. / N.I.</p>	11,84 30,54

Assistance interdite sur l'ensemble du parcours / Assistance forbidden on the whole course

1er e-RVGE

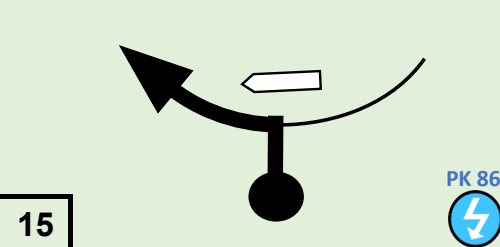
CH	3	Avant ES 3 / Before SS 3 "Corcieux"	SECTION	DISTANCE	PAGE 46
CH	3A	Regroupement & Recharge IN	2	38,70 km	
EPREUVE SPECIALE / SPECIAL STAGE			VITESSE MOYENNE / AVERAGE SPEED	TEMPS IMPARTI / TARGET TIME	
ES/SS	3	"Corcieux"	20,00 km	42,39 km/h	00h55min

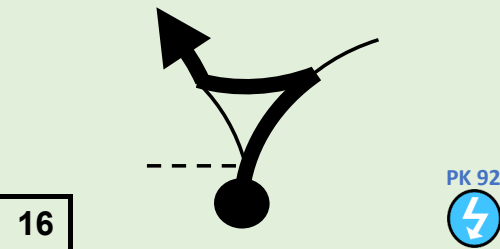
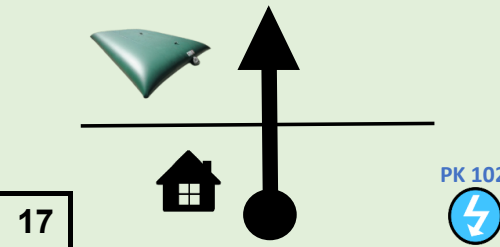
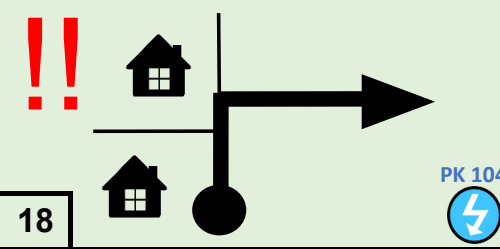
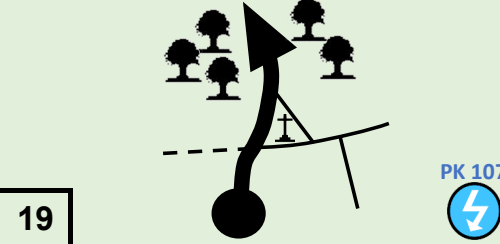
DISTANCE		DIRECTIONS	INFORMATIONS	DISTANCE DEGRESSIVE
TOTALE	PARTIELLE			
8,56	0,40			11,44 30,14
9,16	0,60		S.I. / N.I.	10,84 29,54
10,24	1,08		S.I. / N.I.	9,76 28,46
10,44	0,20		S.I. / N.I.	9,56 28,26
10,69	0,25		S.I. / N.I.	9,31 28,01

Assistance interdite sur l'ensemble du parcours / Assistance forbidden on the whole course

1er e-RVGE







CH	3	Avant ES 3 / Before SS 3 "Corcieux"	SECTION	DISTANCE	PAGE
CH	3A	Regroupement & Recharge IN	2	38,70 km	
EPREUVE SPECIALE / SPECIAL STAGE			VITESSE MOYENNE / AVERAGE SPEED	TEMPS IMPARTI / TARGET TIME	47
ES/SS	3	"Corcieux"	20,00 km	42,39 km/h	

DISTANCE		DIRECTIONS	INFORMATIONS	DISTANCE DEGRESSIVE
TOTALE	PARTIELLE			
11,44	0,75		<p>La Cuisine des Arrentès</p> <p>RESTAURANT -----BAR-----</p>	8,56 27,26
11,58	0,14	<p>D31</p> <p>ARRENTÈS-CORCIEUX</p> <p>20</p>	SRP / FMR D31	8,42 27,12
12,54	0,96		S.I. / N.I.	7,46 26,16
12,78	0,24		<p>C109</p> <p>La Charmelle 0.3</p>	7,22 25,92
12,84	0,06		<p>C109</p> <p>0.3 La Charmelle</p>	7,16 25,86

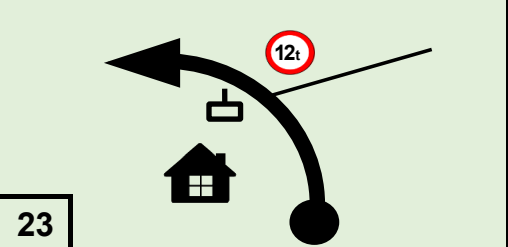
Assistance interdite sur l'ensemble du parcours / Assistance forbidden on the whole course

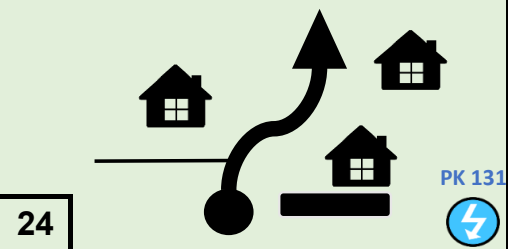
1er e-RVGE

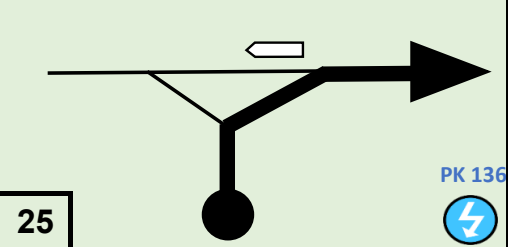

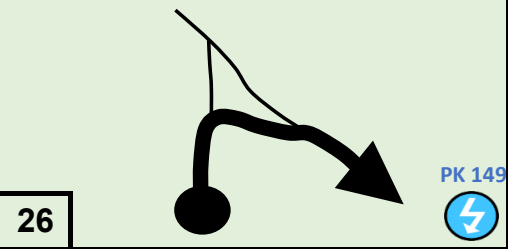
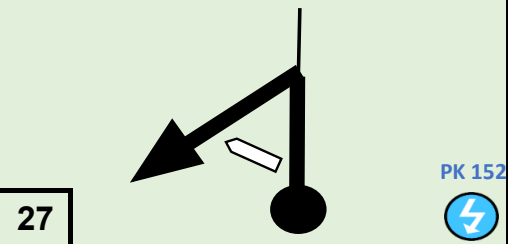
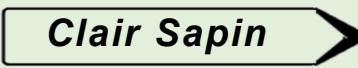



CH	3	Avant ES 3 / Before SS 3 "Corcieux"	SECTION	DISTANCE	PAGE 48
CH	3A	Regroupement & Recharge IN	2	38,70 km	
EPREUVE SPECIALE / SPECIAL STAGE			VITESSE MOYENNE / AVERAGE SPEED	TEMPS IMPARTI / TARGET TIME	
ES/SS	3	"Corcieux"	20,00 km	42,39 km/h	00h55min

DISTANCE		DIRECTIONS	INFORMATIONS	DISTANCE DEGRESSIVE
TOTALE	PARTIELLE			
12,91	0,07			<b style="color: red;">7,09 25,79
13,14	0,23			<b style="color: red;">6,86 25,56
13,58	0,44			<b style="color: red;">6,42 25,12
14,94	1,36		<p style="text-align: center;">S.I. / N.I.</p>	<b style="color: red;">5,06 23,76
15,24	0,30			<b style="color: red;">4,76 23,46

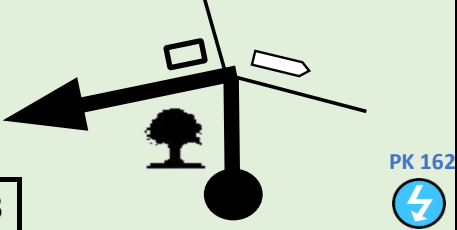
Assistance interdite sur l'ensemble du parcours / Assistance forbidden on the whole course

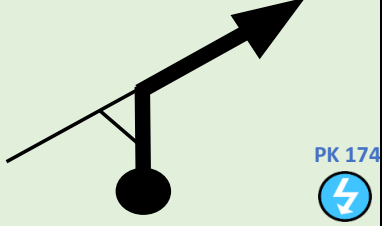
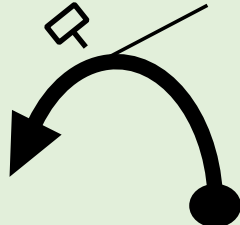
1er e-RVGE

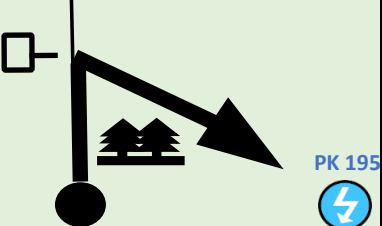
CH	3	Avant ES 3 / Before SS 3 "Corcieux"	SECTION	DISTANCE	PAGE 49
CH	3A	Regroupement & Recharge IN	2	38,70 km	
EPREUVE SPECIALE / SPECIAL STAGE			VITESSE MOYENNE / AVERAGE SPEED	TEMPS IMPARTI / TARGET TIME	
ES/SS	3	"Corcieux"	20,00 km	42,39 km/h	00h55min

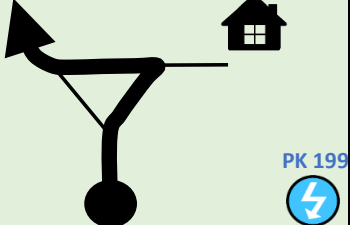
DISTANCE		DIRECTIONS	INFORMATIONS	DISTANCE DEGRESSIVE
TOTALE	PARTIELLE			
16,23	0,99	 <p style="text-align: right; font-size: small;">PK 162</p>	 	3,77 22,47
17,39	1,16	 <p style="text-align: right; font-size: small;">PK 174</p>	S.I. / N.I.	2,61 21,31
17,97	0,58	 <p style="text-align: right; font-size: small;">PK 30</p>		2,03 20,73
19,51	1,54	 <p style="text-align: right; font-size: small;">PK 195</p>		0,49 19,19
19,94	0,43	 <p style="text-align: right; font-size: small;">PK 199</p>	S.I. / N.I.	0,06 18,76

Assistance interdite sur l'ensemble du parcours / Assistance forbidden on the whole course

1er e-RVGE

CH	3	Avant ES 3 / Before SS 3 "Corcieux"	SECTION 2	DISTANCE 38,70 km	PAGE 50
CH	3A	Regroupement & Recharge IN			
EPREUVE SPECIALE / SPECIAL STAGE			VITESSE MOYENNE / AVERAGE SPEED	TEMPS IMPARTI / TARGET TIME	
ES/SS	3	"Corcieux"	20,00 km	42,39 km/h	00h55min

DISTANCE		DIRECTIONS	INFORMATIONS	DISTANCE DEGRESSIVE
TOTALE	PARTIELLE			
20,00	0,06		<p>ARRIVEE / FINISH "CORCIEUX" ES / SS 3</p> <p>Au chemin à droite / At the path on the right</p> <div style="border: 1px solid black; padding: 5px; width: fit-content;"> N 48° 9'12.0" E 6°52'51.6" </div>	0,00 18,70
20,24	0,24		<p>!!!</p> <p>RALENTISSEUR / DECELERATOR</p>	18,46
20,69	0,45		<p>STOP</p> <p>POINT STOP "CORCIEUX" ES / SS 3</p> <p>Au croisement / At the crossroad</p> <div style="border: 1px solid black; padding: 5px; width: fit-content;"> N 48° 9'29.3" E 6°52'32.8" </div>	18,01
21,32	0,63		S.I. / N.I.	17,38
21,53	0,21		S.I. / N.I.	17,17

Assistance interdite sur l'ensemble du parcours / Assistance forbidden on the whole course

1er e-RVGE

CH	3	Avant ES 3 / Before SS 3 "Corcieux"	SECTION 2	DISTANCE 38,70 km	PAGE 51
CH	3A	Regroupement & Recharge IN			
EPREUVE SPECIALE / SPECIAL STAGE			VITESSE MOYENNE / AVERAGE SPEED 42,39 km/h	TEMPS IMPARTI / TARGET TIME 00h55min	
ES/SS					

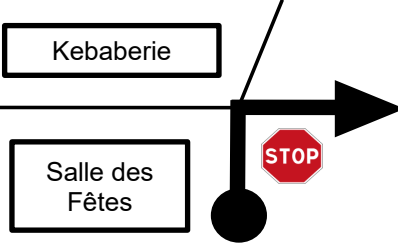
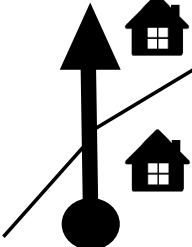
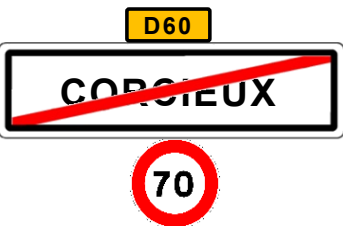
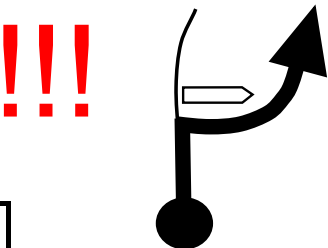
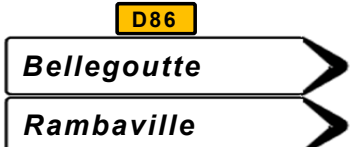
DISTANCE		DIRECTIONS	INFORMATIONS	DISTANCE DEGRESSIVE
TOTALE	PARTIELLE			
22,23	0,70		S.I. / N.I.	16,47
22,38	0,15	 38	S.I. / N.I.	16,32
22,55	0,17	 39	S.I. / N.I.	16,15
23,39	0,84	 40	SRP / FMR D60	15,31
23,75	0,36	 41		14,95

Assistance interdite sur l'ensemble du parcours / Assistance forbidden on the whole course

1er e-RVGE

CH	3	Avant ES 3 / Before SS 3 "Corcieux"	SECTION 2	DISTANCE 38,70 km	PAGE 52
CH	3A	Regroupement & Recharge IN			
EPREUVE SPECIALE / SPECIAL STAGE			<small>VITESSE MOYENNE / AVERAGE SPEED</small> 42,39 km/h	<small>TEMPS IMPARTI / TARGET TIME</small> 00h55min	
ES/SS					

DISTANCE		DIRECTIONS	INFORMATIONS	DISTANCE DEGRESSIVE
TOTALE	PARTIELLE			
24,03	0,28	<div style="text-align: center;"> </div> <div style="text-align: center; border: 1px solid black; width: 30px; margin: 5px auto;">42</div>	S.I. et SRP / N.I. and FMR	14,67
24,13	0,10	<div style="text-align: center;"> </div> <div style="text-align: center; border: 1px solid black; width: 30px; margin: 5px auto;">43</div>	<div style="border: 1px solid black; padding: 5px; display: inline-block; margin-bottom: 10px;"> Rambaville </div> et SRP / and FMR D86	14,57
25,32	1,19	<div style="text-align: center;"> </div> <div style="text-align: center; border: 1px solid black; width: 30px; margin: 5px auto;">44</div>	<div style="border: 1px solid black; padding: 5px; display: inline-block; margin-bottom: 10px;"> La Moine </div> <div style="border: 1px solid black; padding: 5px; display: inline-block;"> Devant Varimont </div>	13,38
25,88	0,56	<div style="text-align: center;"> <div style="border: 1px solid black; padding: 2px; width: 40px; margin: 0 auto;">D86</div> <div style="border: 2px solid red; padding: 5px; width: 150px; margin: 10px auto; text-align: center;"> GERBÉPAL </div> </div> <div style="text-align: center; border: 1px solid black; width: 30px; margin: 5px auto;">45</div>	SRP / FMR D86	12,82
26,18	0,30	<div style="text-align: center;"> </div> <div style="text-align: center; border: 1px solid black; width: 30px; margin: 5px auto;">46</div>	<div style="border: 1px solid black; padding: 5px; display: inline-block; margin-bottom: 10px;"> <div style="border: 1px solid black; padding: 2px; width: 40px; margin: 0 auto;">D8</div> GÉRARDMER 10 </div> et SRP / and FMR D8	12,52

1er e-RVGE

CH	3	Avant ES 3 / Before SS 3 "Corcieux"	SECTION 2	DISTANCE 38,70 km	PAGE 53
CH	3A	Regroupement & Recharge IN			
EPREUVE SPECIALE / SPECIAL STAGE			<small>VITESSE MOYENNE / AVERAGE SPEED</small> 42,39 km/h	<small>TEMPS IMPARTI / TARGET TIME</small> 00h55min	
ES/SS					

DISTANCE		DIRECTIONS	INFORMATIONS	DISTANCE DEGRESSIVE
TOTALE	PARTIELLE			
34,42	8,24	<div style="border: 1px solid black; padding: 5px; display: inline-block;">47</div>	<div style="text-align: center; margin-bottom: 5px;">D417</div> <div style="background-color: green; color: white; padding: 5px; margin-bottom: 5px; display: flex; justify-content: space-between;">ÉPINAL44</div> <div style="border: 1px solid black; padding: 5px; display: flex; justify-content: space-between;">GÉRARDMER3</div>	4,28
35,05	0,63	<div style="border: 1px solid black; padding: 5px; display: inline-block;">48</div>	<div style="text-align: center; margin-bottom: 5px;">D417</div> <div style="background-color: green; color: white; padding: 5px; margin-bottom: 5px; display: flex; justify-content: space-between;">ÉPINAL</div> <div style="border: 1px solid black; padding: 5px; display: flex; justify-content: space-between;">GÉRARDMER- CENTRE</div>	3,65
35,56	0,51	<div style="border: 1px solid black; padding: 5px; display: inline-block;">49</div> <div style="border: 2px solid red; padding: 5px; text-align: center; margin: 10px auto; width: 100px;"> D417 GÉRARDMER </div>	SRP / FMR D417	3,14
36,30	0,74	<div style="border: 1px solid black; padding: 5px; display: inline-block;">50</div>	<div style="text-align: center; margin-bottom: 5px;">D417</div> <div style="background-color: green; color: white; padding: 5px; margin-bottom: 5px; display: flex; justify-content: space-between;">ÉPINAL</div> <div style="border: 1px solid black; padding: 5px; display: flex; justify-content: space-between;">CENTRE VILLE</div>	2,40
36,44	0,14	<div style="border: 1px solid black; padding: 5px; display: inline-block;">50</div>	<div style="text-align: center; margin-bottom: 5px;">D417</div> <div style="background-color: green; color: white; padding: 5px; margin-bottom: 5px; display: flex; justify-content: space-between;">ÉPINAL</div> <div style="border: 1px solid black; padding: 5px; margin-bottom: 5px; display: flex; justify-content: space-between;">REMIREMONTLA BRESSE</div> <div style="border: 1px solid black; padding: 5px; display: flex; justify-content: space-between;">Coteau des XETTESHalle des Sports</div>	2,26

Assistance interdite sur l'ensemble du parcours / Assistance forbidden on the whole course

1er e-RVGE

CH	3	Avant ES 3 / Before SS 3 "Corcieux"	SECTION 2	DISTANCE 38,70 km	PAGE 54
CH	3A	Regroupement & Recharge IN			
EPREUVE SPECIALE / SPECIAL STAGE			<small>VITESSE MOYENNE / AVERAGE SPEED</small> 42,39 km/h	<small>TEMPS IMPARTI / TARGET TIME</small> 00h55min	
ES/SS					

DISTANCE		DIRECTIONS	INFORMATIONS	DISTANCE DEGRESSIVE
TOTALE	PARTIELLE			
37,91	1,47	<div style="text-align: center;"> </div>	S.I. / N.I.	0,79
38,16	0,25	<div style="text-align: center;"> </div>	<div style="text-align: center;"> </div>	0,54
38,32	0,16	<div style="text-align: center;"> </div>	S.I. / N.I.	0,38
38,40	0,08	<div style="text-align: center;"> </div>	<div style="text-align: center;"> </div>	0,30
38,51	0,11	<div style="text-align: center;"> </div>	<div style="text-align: center;"> </div>	0,19

Assistance interdite sur l'ensemble du parcours / Assistance forbidden on the whole course

1er e-RVGE								
CH	3	Avant ES 3 / Before SS 3 "Corcieux"	SECTION	2	DISTANCE	38,70 km	PAGE	55
CH	3A	Regroupement & Recharge IN	VITESSE MOYENNE / AVERAGE SPEED	42,39 km/h	TEMPS IMPARTI / TARGET TIME	00h55min		
EPREUVE SPECIALE / SPECIAL STAGE			ES/SS					
DISTANCE		DIRECTIONS	INFORMATIONS		DISTANCE DEGRESSIVE			
TOTALE	PARTIELLE							
38,64	0,13					0,06		
38,70	0,06		CH 3A Regroupement & Recharge IN N 48°04'13.1" E 6°52'07.9"			0,00		

SECTION 2 | CH 3A

C.H. 3A Regroupement & Recharge IN

N 48°04'13.1" E 6°52'07.9"

1er e-RVGE

CH	3	Avant ES 3 / Before SS 3 "Corcieux"	SECTION 2	DISTANCE 38,77 km	PAGE 54 BIS
CH	3A	Regroupement & Recharge IN			
EPREUVE SPECIALE / SPECIAL STAGE			VITESSE MOYENNE / AVERAGE SPEED	TEMPS IMPARTI / TARGET TIME	
ES/SS			42,29 km/h	00h55min	

DISTANCE		DIRECTIONS	INFORMATIONS	DISTANCE DEGRESSIVE
TOTALE	PARTIELLE			
38,64	0,13			0,16
38,71	0,07		S.I. / N.I.	0,09
38,80	0,09			0,00





SECTION 2 CH 3A

C.H. 3A Regroupement & Recharge IN

N 48° 4'12.2" E 6°52'4.7"









1er e-RVGE

CH	3A	Regroupement & Recharge IN	SECTION 2	DISTANCE 0,00 km	PAGE 55 BIS
CH	3B	Regroupement OUT - Assistance IN			
EPREUVE SPECIALE / SPECIAL STAGE			<small>VITESSE MOYENNE / AVERAGE SPEED</small> -	<small>TEMPS IMPARTI / TARGET TIME</small> 02h36min	
ES/SS					

DISTANCE		DIRECTIONS	INFORMATIONS	DISTANCE DEGRESSIVE
TOTALE	PARTIELLE			
0,00	0,00	PARK 	<u>Regroupement & Recharge IN</u>	0,00
0,00	0,00	 PARK 	 <u>CH 3B</u> Regroupement OUT - Assistance IN  N 48°4'20.1" E 6°52'23.6"	0,00
		1		

1er e-RVGE

CH	3B	Regroupement OUT - Assistance IN	SECTION 3	DISTANCE 0,00 km	PAGE 56 BIS
CH	3C	Assistance OUT			
EPREUVE SPECIALE / SPECIAL STAGE			VITESSE MOYENNE / AVERAGE SPEED -	TEMPS IMPARTI / TARGET TIME 01h15min	
ES/SS					

DISTANCE		DIRECTIONS	INFORMATIONS	DISTANCE DEGRESSIVE
TOTALE	PARTIELLE			
0,00	0,00	 PARK 	 <u>CH 3B</u> Regroupement OUT - Assistance IN  N 48°4'20.1" E 6°52'23.6"	0,00
0,00	0,00	 PARK 	 <u>CH 3C</u> Assistance OUT  N 48°4'20.1" E 6°52'23.6"	0,00
		1		

1er e-RVGE

CH	3C	Assistance OUT	SECTION	DISTANCE	PAGE
CH	6	Avant ES 6 / Before SS 6 "Corcieux"	3	24,02 km	
EPREUVE SPECIALE / SPECIAL STAGE			VITESSE MOYENNE / AVERAGE SPEED	TEMPS IMPARTI / TARGET TIME	57 BIS
ES/SS			41,18 km/h	00h35mn	

DISTANCE		DIRECTIONS	INFORMATIONS	DISTANCE DEGRESSIVE
TOTALE	PARTIELLE			
0,00	0,00		CH 3C Assistance OUT N 48° 4'15.4" E 6°52'1.2"	24,02
0,08	0,08		S.I. / N.I.	23,94
0,19	0,11	<div style="border: 1px solid black; padding: 2px; width: fit-content; margin-bottom: 5px;">6 Bar à Vins Restaurant</div>	S.I. / N.I.	23,83
		1		
0,43	0,24		Coteau des Xettes	23,59
0,51	0,08		puis reprendre / then resume Case 2 page 59 à / at 0,23 km	23,51
		2		

Assistance interdite sur l'ensemble du parcours / Assistance forbidden on the whole course

1er e-RVGE

CH	3A	Regroupement & Recharge IN	SECTION 2	DISTANCE 0,58 km	PAGE 56
CH	-	-			
EPREUVE SPECIALE / SPECIAL STAGE			VITESSE MOYENNE / AVERAGE SPEED	TEMPS IMPARTI / TARGET TIME	
ES/SS					





DISTANCE		DIRECTIONS	INFORMATIONS	DISTANCE DEGRESSIVE
TOTALE	PARTIELLE			
0,00	0,00		<p>CH 3A Regroupement & Recharge IN</p> <div style="border: 1px solid black; padding: 5px; width: fit-content;"> N 48°04'13.1" E 6°52'07.9" </div>	0,58
0,06	0,06		S.I. / N.I.	0,52
0,17	0,11	<div style="border: 1px solid black; padding: 2px; width: 20px; text-align: center; margin-top: 5px;">1</div>	S.I. et SRP / N.I. and FMR	0,41
0,41	0,24	<div style="border: 1px solid black; padding: 2px; width: 20px; text-align: center; margin-top: 5px;">3</div>	Coteau des Xettes	0,17
0,49	0,08	<div style="border: 1px solid black; padding: 2px; width: 20px; text-align: center; margin-top: 5px;">4</div>	S.I. / N.I.	0,09

Assistance interdite sur l'ensemble du parcours / Assistance forbidden on the whole course

1er e-RVGE						
CH	3A	Regroupement & Recharge IN		SECTION	DISTANCE	PAGE
CH	-	-		2	0,58 km	
EPREUVE SPECIALE / SPECIAL STAGE				VITESSE MOYENNE / AVERAGE SPEED	TEMPS IMPARTI / TARGET TIME	57
ES/SS						
DISTANCE		DIRECTIONS	INFORMATIONS	DISTANCE		
TOTALE	PARTIELLE			DEGRESSIVE		
0,58	0,09		<u>Regroupement & Recharge IN</u>	0,00		









1er e-RVGE

CH	-	-	SECTION 2	DISTANCE 0,00 km	PAGE 58
CH	3B	Regroupement OUT - Assistance IN			
EPREUVE SPECIALE / SPECIAL STAGE			VITESSE MOYENNE / AVERAGE SPEED -	TEMPS IMPARTI / TARGET TIME 02h36min	
ES/SS					

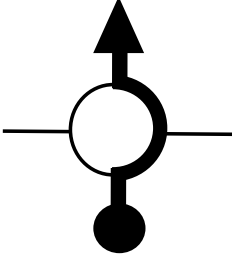
DISTANCE		DIRECTIONS	INFORMATIONS	DISTANCE DEGRESSIVE
TOTALE	PARTIELLE			
0,00	0,00	<p>PARC</p> 	<p><u>Regroupement & Recharge IN</u></p>	0,00
0,00	0,00	<p>PARC</p>  <p>1</p>	<p><u>CH 3B</u></p> <p>Regroupement OUT - Assistance IN - P. de la Prairie</p>  <div style="border: 1px solid black; padding: 5px; width: fit-content; margin-top: 10px;">  N 48°4'20.1" E 6°52'23.6" </div>	0,00

1er e-RVGE

CH	3B	Regroupement OUT - Assistance IN	SECTION 3	DISTANCE 0,58 km	PAGE 59
CH	3C	Assistance OUT			
EPREUVE SPECIALE / SPECIAL STAGE			VITESSE MOYENNE / AVERAGE SPEED -	TEMPS IMPARTI / TARGET TIME 01h15min	
ES/SS					

DISTANCE		DIRECTIONS	INFORMATIONS	DISTANCE DEGRESSIVE
TOTALE	PARTIELLE			
0,00	0,00	 <div style="border: 1px solid black; padding: 5px; margin: 10px auto; width: 150px;"> <p style="text-align: center;">PARC</p> <p style="text-align: center;">TROPHÉE</p> <h1 style="text-align: center; margin: 0;">A290</h1> <p style="text-align: center;">RALLYE</p> </div>	<p>CH 3B</p> <p>Regroupement OUT - Assistance IN - P. de la Prairie</p> <div style="border: 1px solid black; padding: 5px; margin-top: 10px; width: fit-content;"> <p>N 48°4'20.1" E 6°52'23.6"</p> </div>	0,58
0,09	0,09	 <div style="border: 1px solid black; padding: 5px; margin: 10px auto; width: 100px;"> <p style="text-align: center;">Parc P. de la Prairie</p> </div> <div style="border: 1px solid black; padding: 2px; width: 20px; text-align: center; margin-top: 10px;">1</div>	S.I. / N.I.	0,49
0,29	0,20	<div style="border: 1px solid black; padding: 5px; margin: 10px auto; width: 40px; transform: rotate(-90deg);"> <p style="text-align: center;">LINVOSGES</p> </div>  <div style="border: 1px solid black; padding: 2px; width: 20px; text-align: center; margin-top: 10px;">2</div>	S.I. / N.I.	0,29
0,50	0,21	  <div style="border: 1px solid black; padding: 5px; margin: 10px auto; width: 80px;">  <p style="text-align: center;">CAISSE D'EPARGNE</p> </div>	S.I. / N.I.	0,08
0,58	0,08	<div style="border: 1px solid black; padding: 5px; margin: 10px auto; width: 40px; transform: rotate(-90deg);"> <p style="text-align: center;">Cimetière</p> </div>  <div style="border: 1px solid black; padding: 5px; margin: 10px auto; width: 60px;"> <p style="text-align: center;">batt</p> </div>  <div style="border: 1px solid black; padding: 2px; width: 20px; text-align: center; margin-top: 10px;">3</div>	<p>CH 3C</p> <p>Assistance OUT</p> <div style="border: 1px solid black; padding: 5px; margin-top: 10px; width: fit-content;"> <p>N 48°4'28.0" E 6°52'43.1"</p> </div>	0,00

Assistance interdite sur l'ensemble du parcours / Assistance forbidden on the whole course

1er e-RVGE						
CH	3B	Regroupement OUT - Assistance IN		SECTION	DISTANCE	PAGE 60
CH	3C	Assistance OUT		3	0,58 km	
EPREUVE SPECIALE / SPECIAL STAGE				VITESSE MOYENNE / AVERAGE SPEED	TEMPS IMPARTI / TARGET TIME	
ES/SS				-	01h15min	
DISTANCE		DIRECTIONS		INFORMATIONS		DISTANCE DEGRESSIVE
TOTALE	PARTIELLE					

SECTION 3	CH 3C
-----------	-------

C.H. 3C Assistance OUT

 N 48°4'28.0" E 6°52'43.1"



1er e-RVGE

CH	3C	Assistance OUT	SECTION	DISTANCE	PAGE
CH	6	Avant ES 6 / Before SS 6 "Corcieux"	3	22,96 km	
EPREUVE SPECIALE / SPECIAL STAGE			VITESSE MOYENNE / AVERAGE SPEED	TEMPS IMPARTI / TARGET TIME	61
ES/SS			39,36 km/h	00h35min	

DISTANCE		DIRECTIONS	INFORMATIONS	DISTANCE DEGRESSIVE
TOTALE	PARTIELLE			
0,00	0,00		<p>CH 3C Service OUT</p> <div style="border: 1px solid black; padding: 2px; display: inline-block;"> N 48°4'28.0" E 6°52'43.1" </div>	22,96
0,07	0,07	<div style="border: 1px solid black; padding: 2px; display: inline-block; margin-bottom: 5px;">1</div>	<div style="border: 1px solid black; padding: 5px; display: inline-block; width: 100px;"> AUTRES DIRECTIONS </div>	22,89
0,28	0,21		<div style="border: 1px solid black; padding: 5px; display: inline-block; width: 100px; margin-bottom: 5px;"> COLMAR </div> <div style="border: 1px solid black; padding: 5px; display: inline-block; width: 100px;"> BRUYÈRES SAINT - DIÉ </div>	22,68
0,37	0,09	<div style="border: 1px solid black; padding: 2px; display: inline-block; margin-bottom: 5px;">2</div>	<div style="border: 1px solid black; padding: 5px; display: inline-block; width: 100px; margin-bottom: 5px; background-color: #90EE90;"> COLMAR </div> <div style="border: 1px solid black; padding: 5px; display: inline-block; width: 100px; margin-bottom: 5px;"> BRUYÈRES SAINT - DIÉ </div> <div style="border: 1px solid black; padding: 5px; display: inline-block; width: 100px;"> XONRUPT - LONGEMER </div>	22,59
0,55	0,18	<div style="border: 1px solid black; padding: 2px; display: inline-block; margin-bottom: 5px;">3</div>	<div style="border: 1px solid black; padding: 5px; display: inline-block; width: 100px; margin-bottom: 5px;"> BRUYERES SAINT - DIE </div> <div style="border: 1px solid black; padding: 5px; display: inline-block; width: 100px; margin-bottom: 5px;"> XONRUPT -LONGEMER </div> <div style="border: 1px solid black; padding: 5px; display: inline-block; width: 100px;"> COLMAR </div>	22,41

Assistance interdite sur l'ensemble du parcours / Assistance forbidden on the whole course

1er e-RVGE











CH	3C	Assistance OUT	SECTION	DISTANCE	PAGE
CH	6	Avant ES 6 / Before SS 6 "Corcieux"	3	22,96 km	
EPREUVE SPECIALE / SPECIAL STAGE			VITESSE MOYENNE / AVERAGE SPEED	TEMPS IMPARTI / TARGET TIME	62
ES/SS			39,36 km/h	00h35min	

DISTANCE		DIRECTIONS	INFORMATIONS	DISTANCE DEGRESSIVE
TOTALE	PARTIELLE			
0,76	0,21		D417 COLMAR XONRUPT - LONGEMER BRUYERES SAINT - DIÉ	22,20
0,89	0,13	4 	D423 GRANGES^s / V. BRUYÈRES KICHOMPRE LE KERTOFF	22,07
1,41	0,52	5 	SRP / FMR D423	21,55
2,39	0,98	6 	SRP / FMR D423	20,57
3,29	0,90	7 	SRP / FMR D423	19,67

Assistance interdite sur l'ensemble du parcours / Assistance forbidden on the whole course

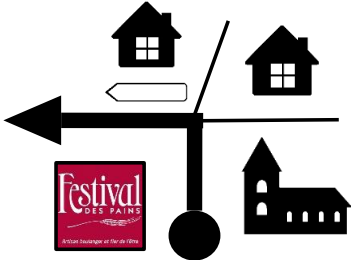
1er e-RVGE









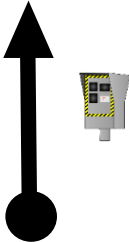

CH	3C	Assistance OUT	SECTION 3	DISTANCE 22,96 km	PAGE 63
CH	6	Avant ES 6 / Before SS 6 "Corcieux"			
EPREUVE SPECIALE / SPECIAL STAGE			VITESSE MOYENNE / AVERAGE SPEED 39,36 km/h	TEMPS IMPARTI / TARGET TIME 00h35min	
ES/SS					

DISTANCE		DIRECTIONS	INFORMATIONS	DISTANCE DEGRESSIVE
TOTALE	PARTIELLE			
3,98	0,69	 	SRP / FMR D423	18,98
		8		
4,62	0,64	 	SRP / FMR D423	18,34
		9		
11,30	6,68	 	SRP / FMR D423	11,66
		10		
12,49	1,19		  et SRP / and FMR D423	10,47
		11		
13,68	1,19	 	SRP / FMR D423	9,28
		12		

Assistance interdite sur l'ensemble du parcours / Assistance forbidden on the whole course

1er e-RVGE

CH	3C	Assistance OUT	SECTION 3	DISTANCE 22,96 km	PAGE 64
CH	6	Avant ES 6 / Before SS 6 "Corcieux"			
EPREUVE SPECIALE / SPECIAL STAGE			VITESSE MOYENNE / AVERAGE SPEED 39,36 km/h	TEMPS IMPARTI / TARGET TIME 00h35min	
ES/SS					

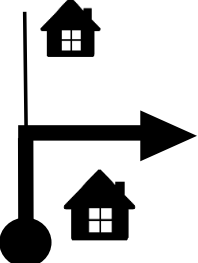
DISTANCE		DIRECTIONS	INFORMATIONS	DISTANCE DEGRESSIVE
TOTALE	PARTIELLE			
14,93	1,25	  13	SRP / FMR D423	8,03
15,19	0,26	 14	ATTENTION / WARNING RADAR SRP / FMR D423	7,77
15,71	0,52	   15	SRP / FMR D423	7,25
16,83	1,12	  16	SRP / FMR D423	6,13
17,42	0,59	    17	S.I. / N.I.	5,54

Assistance interdite sur l'ensemble du parcours / Assistance forbidden on the whole course

1er e-RVGE



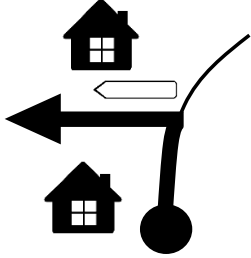
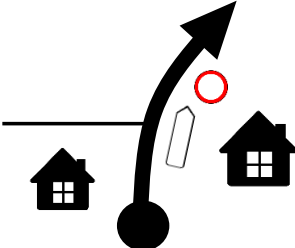
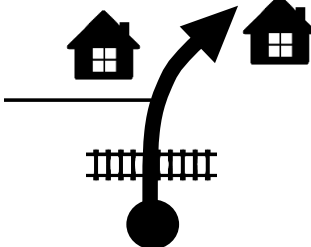
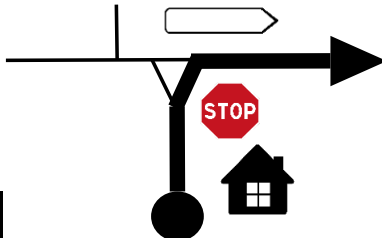
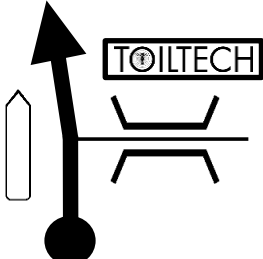







CH	3C	Assistance OUT	SECTION	DISTANCE	PAGE
CH	6	Avant ES 6 / Before SS 6 "Corcieux"	3	22,96 km	
EPREUVE SPECIALE / SPECIAL STAGE			VITESSE MOYENNE / AVERAGE SPEED	TEMPS IMPARTI / TARGET TIME	65
ES/SS			39,36 km/h	00h35min	

DISTANCE		DIRECTIONS	INFORMATIONS	DISTANCE DEGRESSIVE
TOTALE	PARTIELLE			
17,81	0,39	 <p>18</p>	<p>LA CHAPELLE par LA ROSIÈRE</p> <p>LA CHAPELLE</p>	5,15
18,11	0,30	 <p>19</p>	<p>LA CHAPELLE</p> <p>12t 100 m</p>	4,85
18,40	0,29	 <p>20</p>	S.I. / N.I.	4,56
18,82	0,42	 <p>21</p>	<p>D60</p> <p>LA CHAPELLE 2 DEVANT BRUYÈRES</p> <p>CORCIEUX 9</p>	4,14
19,85	1,03	 <p>22</p>	<p>D81</p> <p>LES POULIÈRES 1.5 BIFFONTAINE 3.5</p> <p>LA HOUSSIÈRE 7</p> <p>et SRP / and FMR D81</p>	3,11

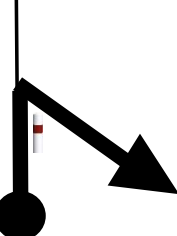
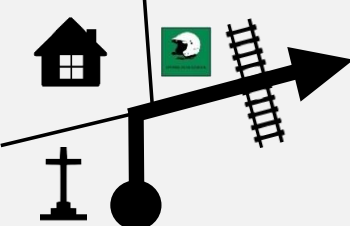
Assistance interdite sur l'ensemble du parcours / Assistance forbidden on the whole course

1er e-RVGE

CH	3C	Assistance OUT	SECTION	DISTANCE	PAGE 66
CH	6	Avant ES 6 / Before SS 6 "Corcieux"	3	22,96 km	
EPREUVE SPECIALE / SPECIAL STAGE			VITESSE MOYENNE / AVERAGE SPEED	TEMPS IMPARTI / TARGET TIME	
ES/SS			39,36 km/h	00h35min	

DISTANCE		DIRECTIONS	INFORMATIONS	DISTANCE DEGRESSIVE
TOTALE	PARTIELLE			
20,75	0,90	  23	SRP / FMR D81	2,21
21,91	1,16	  24	SRP / FMR D81	1,05
22,46	0,55	  25	S.I. / N.I.	0,50
22,94	0,48		 !!! VOIE FERREE ACTIVE / ACTIVE RAILWAY !!!	0,02
22,96	0,02	   26	 CH 6 Avant ES6 / Before SS6 <div style="border: 1px solid black; padding: 5px; margin-top: 5px;">  N 48°12'20.5" E 6°48'25.6" </div> 0,16 km avant Départ ES6 / before start of SS6 "Corcieux"	0,00

Assistance interdite sur l'ensemble du parcours / Assistance forbidden on the whole course

1er e-RVGE

EPREUVE SPECIALE / SPECIAL STAGE

SECTION

3

PAGE

67

ES/SS

6

"Corcieux"

20,00 km

1ère / 1st
A290
20h07

C.H. 6

N 48°12'20.5"
E 6°48'25.6"

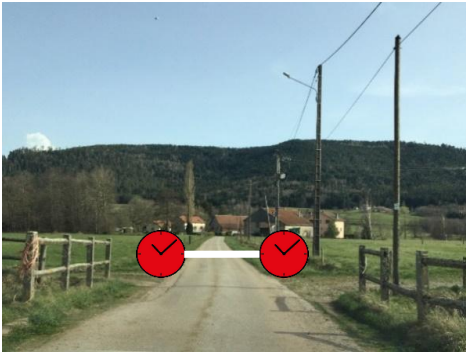

DEPART / START

N 48°12'16.3"
E 6°48'29.4"

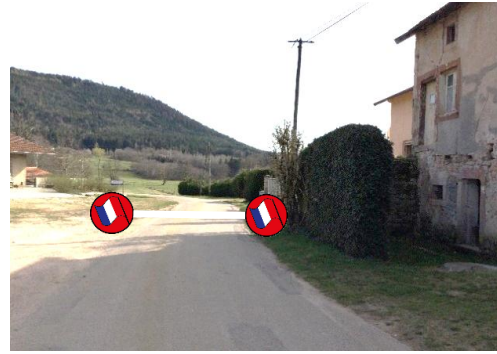

ARRIVEE / FINISH

N 48° 9'12.0"
E 6°52'51.6"



POINT STOP

N 48° 9'29.3"
E 6°52'32.8"



Fermeture de la route à / Road closure at :

1ère/1st car :

08h00 - 23h00

20h07

68



ES 3 - ES 6 Corcieux : 20 km
Samedi 13 juin 2026
 ES 3: 12h04 - ES 6: 17h28
 Horaires sous réserve de modifications.

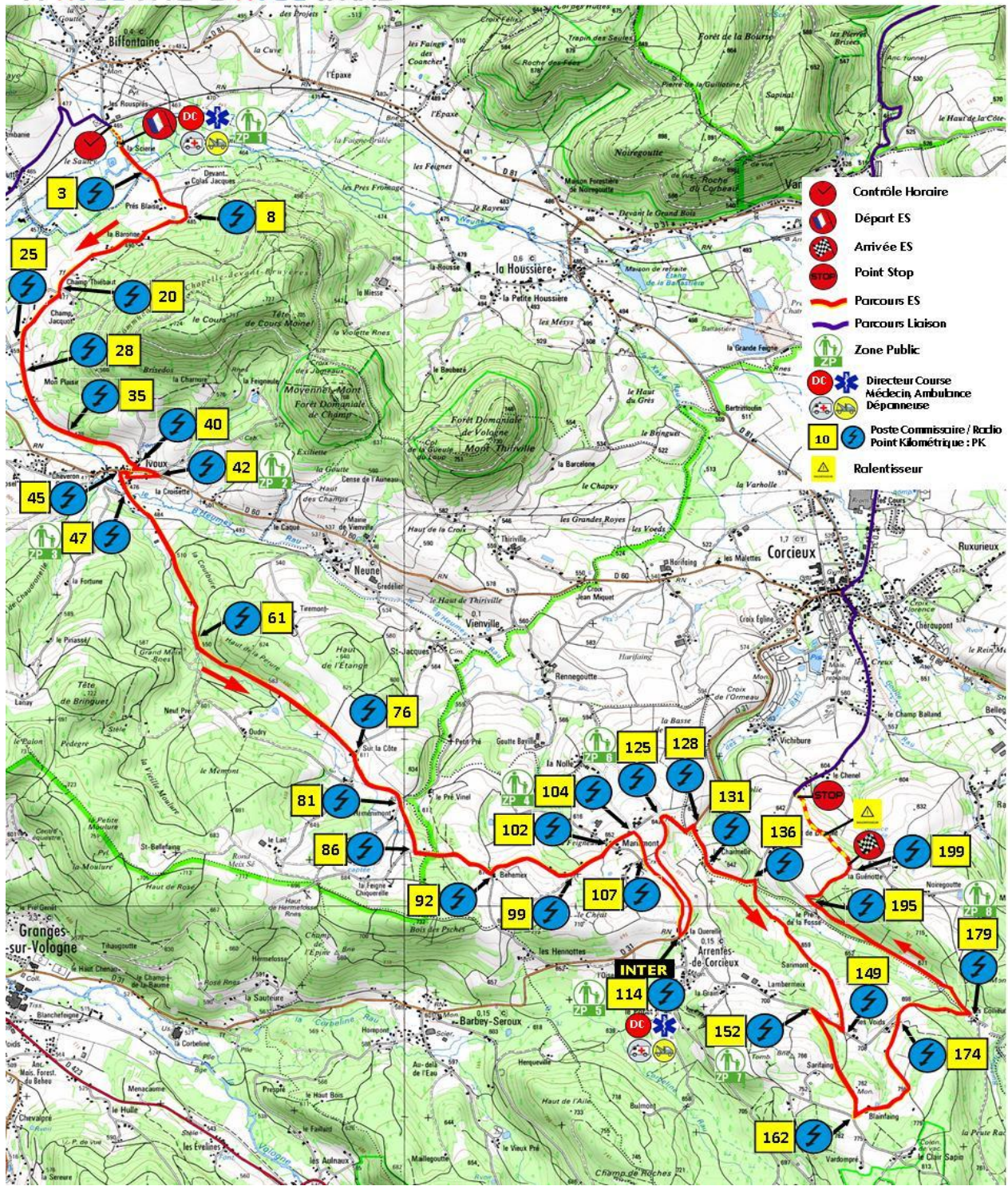

1er e-RVGE







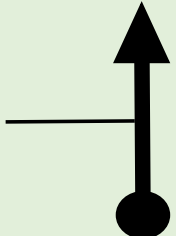
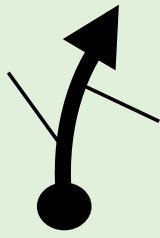

CH	6	Avant ES 6 / Before SS 6 "Corcieux"	SECTION	DISTANCE	PAGE 69
CH	6A	Assistance IN	3	38,70 km	
EPREUVE SPECIALE / SPECIAL STAGE			VITESSE MOYENNE / AVERAGE SPEED	TEMPS IMPARTI / TARGET TIME	
ES/SS	6	"Corcieux"	20,00 km	42,39 km/h	00h55min

DISTANCE		DIRECTIONS	INFORMATIONS	DISTANCE DEGRESSIVE
TOTALE	PARTIELLE			
0,00	0,00		<p>DEPART / START "CORCIEUX" ES / SS 6 Entre les maisons / Between the houses</p> <div style="border: 1px solid black; padding: 5px; width: fit-content; margin: 10px auto;"> <p>N 48°12'16.3" E 6°48'29.4"</p> </div>	20,00
0,52	0,52		S.I. / N.I.	19,48
0,58	0,06		S.I. / N.I.	19,42
0,80	0,22		S.I. / N.I.	19,20
1,22	0,42		S.I. / N.I.	18,78

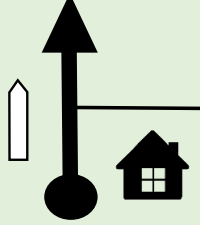
Assistance interdite sur l'ensemble du parcours / Assistance forbidden on the whole course

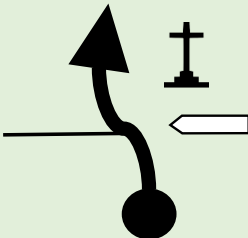
1er e-RVGE

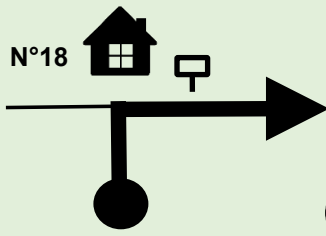
CH	6	Avant ES 6 / Before SS 6 "Corcieux"	SECTION	DISTANCE	PAGE 70
CH	6A	Assistance IN	3	38,70 km	
EPREUVE SPECIALE / SPECIAL STAGE			VITESSE MOYENNE / AVERAGE SPEED	TEMPS IMPARTI / TARGET TIME	
ES/SS	6	"Corcieux"	20,00 km	42,39 km/h	00h55min

DISTANCE		DIRECTIONS	INFORMATIONS	DISTANCE DEGRESSIVE
TOTALE	PARTIELLE			
1,87	0,65		S.I. / N.I.	18,13 36,83
2,01	0,14	<div style="border: 1px solid black; padding: 2px; display: inline-block; margin-bottom: 5px;">5</div>  <div style="text-align: right; margin-top: 5px;">  </div>	S.I. / N.I.	17,99 36,69
2,53	0,52	<div style="border: 1px solid black; padding: 2px; display: inline-block; margin-bottom: 5px;">6</div>  <div style="text-align: right; margin-top: 5px;">  </div>	<div style="border: 1px solid black; padding: 5px; display: inline-block;"> Yvoux  </div>	17,47 36,17
2,78	0,25	<div style="border: 1px solid black; padding: 2px; display: inline-block; margin-bottom: 5px;">7</div>  <div style="text-align: right; margin-top: 5px;">  </div>	 <p style="text-align: center; color: green; font-size: small;">ROUTE DE LA CARRIERE</p> <p style="text-align: center;">.....1266..</p> <p style="text-align: center;">et SRP / and FMR</p>	17,22 35,92
4,02	1,24	<div style="border: 1px solid black; padding: 2px; display: inline-block; margin-bottom: 5px;">8</div>  <div style="text-align: right; margin-top: 5px;">  </div>	<div style="border: 2px solid blue; padding: 5px; display: inline-block; background-color: white;"> <p style="text-align: center; margin: 0;">RUE DES CHAMPS THOMAS</p> </div>	15,98 34,68

Assistance interdite sur l'ensemble du parcours / Assistance forbidden on the whole course

1er e-RVGE

CH	6	Avant ES 6 / Before SS 6 "Corcieux"	SECTION	DISTANCE	PAGE 71
CH	6A	Assistance IN	3	38,70 km	
EPREUVE SPECIALE / SPECIAL STAGE			VITESSE MOYENNE / AVERAGE SPEED	TEMPS IMPARTI / TARGET TIME	
ES/SS	6	"Corcieux"	20,00 km	42,39 km/h	00h55min

DISTANCE		DIRECTIONS	INFORMATIONS	DISTANCE DEGRESSIVE
TOTALE	PARTIELLE			
4,05	0,03			15,95 34,65
4,22	0,17		S.I. / N.I.	15,78 34,48
4,43	0,21		S.I. / N.I.	15,57
4,48	0,05			15,52 34,22
4,54	0,06			15,46 34,16

Assistance interdite sur l'ensemble du parcours / Assistance forbidden on the whole course

1er e-RVGE









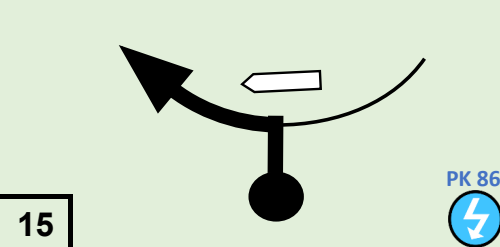

CH	6	Avant ES 6 / Before SS 6 "Corcieux"	SECTION 3	DISTANCE 38,70 km	PAGE 72
CH	6A	Assistance IN			
EPREUVE SPECIALE / SPECIAL STAGE			VITESSE MOYENNE / AVERAGE SPEED 42,39 km/h	TEMPS IMPARTI / TARGET TIME 00h55min	
ES/SS	6	"Corcieux"	20,00 km		

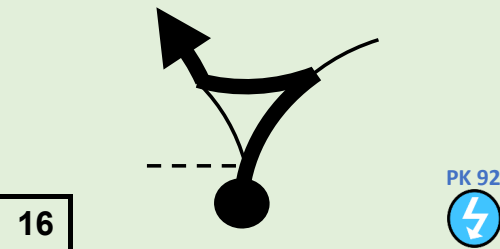
DISTANCE		DIRECTIONS	INFORMATIONS	DISTANCE DEGRESSIVE
TOTALE	PARTIELLE			
4,69	0,15		<p><i>La Naye</i></p> <p><i>La Fortune</i></p>	<p>15,31</p> <p>34,01</p>
7,61	2,92		<p><i>Le Neuf Pré</i></p>	<p>12,39</p> <p>31,09</p>
7,66	0,05		<p><i>Houdry</i></p> <p><i>Monument Georges</i></p> <p><i>Le Neuf Pré</i></p>	<p>12,34</p> <p>31,04</p>
8,12	0,46		<p>!!!</p> <p>S.I. / N.I.</p>	<p>11,88</p> <p>30,58</p>
8,16	0,04		<p>S.I. / N.I.</p>	<p>11,84</p> <p>30,54</p>

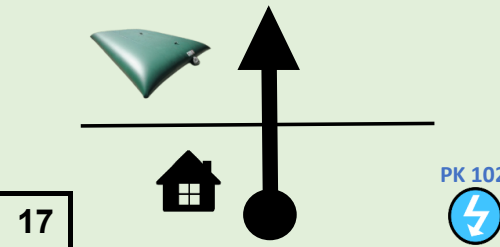
Assistance interdite sur l'ensemble du parcours / Assistance forbidden on the whole course

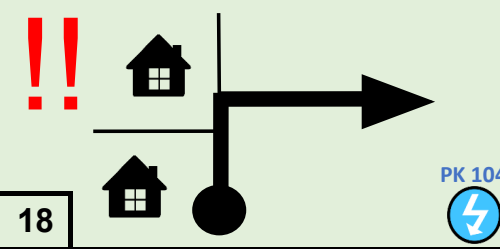
1er e-RVGE

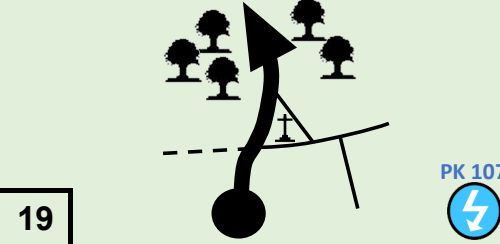
CH	6	Avant ES 6 / Before SS 6 "Corcieux"	SECTION	DISTANCE	PAGE 73
CH	6A	Assistance IN	3	38,70 km	
EPREUVE SPECIALE / SPECIAL STAGE			VITESSE MOYENNE / AVERAGE SPEED	TEMPS IMPARTI / TARGET TIME	
ES/SS	6	"Corcieux"	20,00 km	42,39 km/h	00h55min

DISTANCE		DIRECTIONS	INFORMATIONS	DISTANCE DEGRESSIVE
TOTALE	PARTIELLE			
8,56	0,40	 <p style="text-align: right; margin-right: 10px;">PK 86 </p>		11,44 30,14
9,16	0,60	 <p style="text-align: right; margin-right: 10px;">PK 92 </p>	S.I. / N.I.	10,84 29,54
10,24	1,08	 <p style="text-align: right; margin-right: 10px;">PK 102 </p>	S.I. / N.I.	9,76 28,46
10,44	0,20	 <p style="text-align: right; margin-right: 10px;">PK 104 </p>	S.I. / N.I.	9,56 28,26
10,69	0,25	 <p style="text-align: right; margin-right: 10px;">PK 107 </p>	S.I. / N.I.	9,31 28,01

Assistance interdite sur l'ensemble du parcours / Assistance forbidden on the whole course

1er e-RVGE



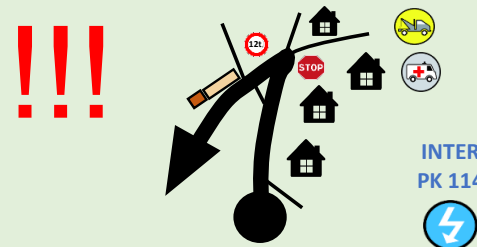
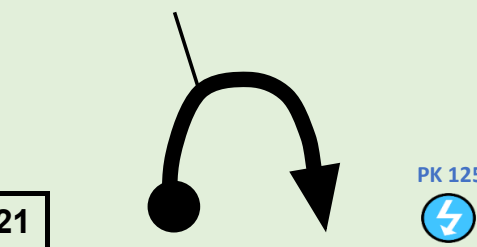
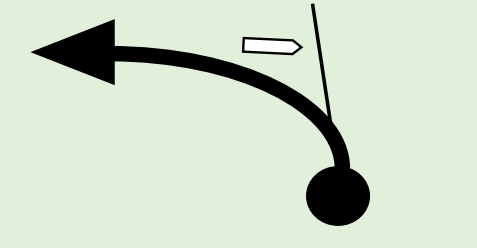
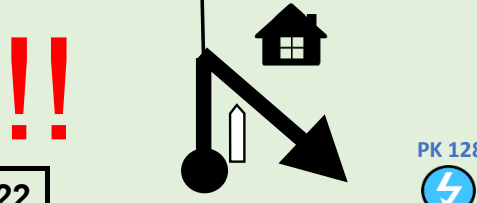



CH	6	Avant ES 6 / Before SS 6 "Corcieux"	SECTION	DISTANCE	PAGE 74
CH	6A	Assistance IN	3	38,70 km	
EPREUVE SPECIALE / SPECIAL STAGE			VITESSE MOYENNE / AVERAGE SPEED	TEMPS IMPARTI / TARGET TIME	
ES/SS	6	"Corcieux"	20,00 km	42,39 km/h	00h55min

DISTANCE		DIRECTIONS	INFORMATIONS	DISTANCE DEGRESSIVE
TOTALE	PARTIELLE			
11,44	0,75		<div style="border: 1px solid black; padding: 2px; margin-bottom: 5px;">La Cuisine des Arrentès</div> <div style="border: 2px solid brown; padding: 5px; text-align: center; margin-bottom: 5px;">RESTAURANT</div> <div style="border: 1px dashed black; padding: 2px; text-align: center;">-----BAR-----</div>	8,56
11,58	0,14	<div style="border: 1px solid black; padding: 2px; margin-bottom: 5px; text-align: center;">D31</div> <div style="border: 2px solid black; padding: 5px; text-align: center; color: red;">ARRENTÈS- LE-CORCIEUX</div> <div style="border: 1px solid black; padding: 2px; margin-top: 5px; text-align: center;">20</div>	SRP / FMR D31	8,42
12,54	0,96		S.I. / N.I.	7,46
12,78	0,24		<div style="border: 1px solid black; padding: 2px; margin-bottom: 5px; text-align: center;">C109</div> <div style="border: 1px solid black; padding: 2px; text-align: center; color: red;">La Charmelle 0.3</div>	7,22
12,84	0,06		<div style="border: 1px solid black; padding: 2px; margin-bottom: 5px; text-align: center;">C109</div> <div style="border: 1px solid black; padding: 2px; text-align: center;">0.3 La Charmelle</div>	7,16

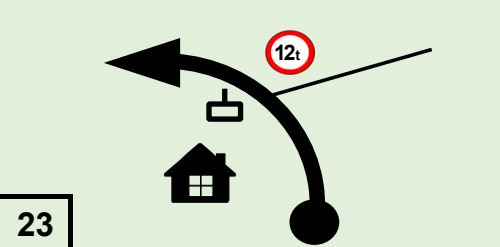
Assistance interdite sur l'ensemble du parcours / Assistance forbidden on the whole course

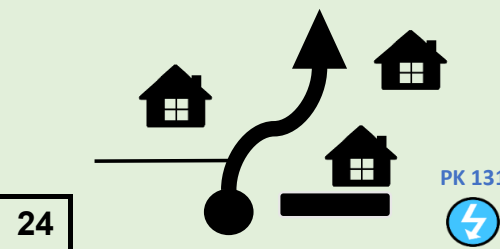
1er e-RVGE

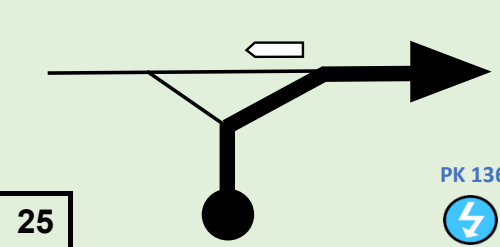

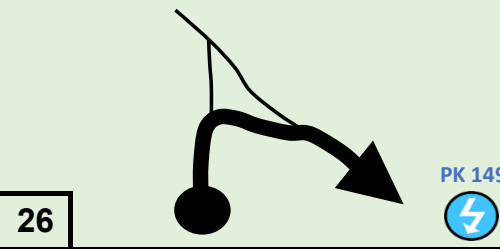
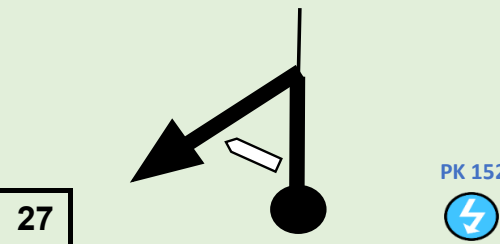
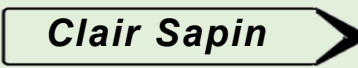



CH	6	Avant ES 6 / Before SS 6 "Corcieux"	SECTION	DISTANCE	PAGE 75
CH	6A	Assistance IN	3	38,70 km	
EPREUVE SPECIALE / SPECIAL STAGE			VITESSE MOYENNE / AVERAGE SPEED	TEMPS IMPARTI / TARGET TIME	
ES/SS	6	"Corcieux"	20,00 km	42,39 km/h	00h55min

DISTANCE		DIRECTIONS	INFORMATIONS	DISTANCE DEGRESSIVE
TOTALE	PARTIELLE			
12,91	0,07			<b style="color: red;">7,09 25,79
13,14	0,23			<b style="color: red;">6,86 25,56
13,58	0,44			<b style="color: red;">6,42 25,12
14,94	1,36		<p style="text-align: center;">S.I. / N.I.</p>	<b style="color: red;">5,06 23,76
15,24	0,30			<b style="color: red;">4,76 23,46

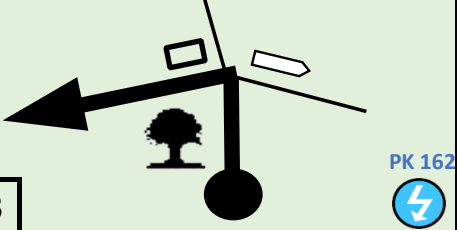
Assistance interdite sur l'ensemble du parcours / Assistance forbidden on the whole course

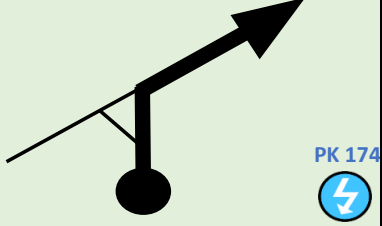
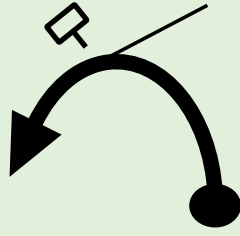
1er e-RVGE

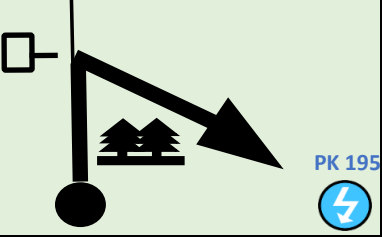
CH	6	Avant ES 6 / Before SS 6 "Corcieux"	SECTION 3	DISTANCE 38,70 km	PAGE 76
CH	6A	Assistance IN			
EPREUVE SPECIALE / SPECIAL STAGE			VITESSE MOYENNE / AVERAGE SPEED 42,39 km/h	TEMPS IMPARTI / TARGET TIME 00h55min	
ES/SS	6	"Corcieux"	20,00 km		

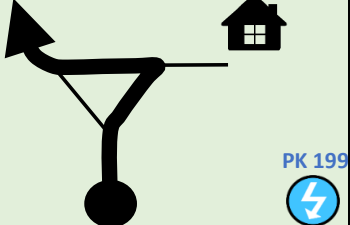
DISTANCE		DIRECTIONS	INFORMATIONS	DISTANCE DEGRESSIVE
TOTALE	PARTIELLE			
16,23	0,99		 	3,77 22,47
17,39	1,16		S.I. / N.I.	2,61 21,31
17,97	0,58			2,03 20,73
19,51	1,54			0,49 19,19
19,94	0,43		S.I. / N.I.	0,06 18,76

Assistance interdite sur l'ensemble du parcours / Assistance forbidden on the whole course

1er e-RVGE

CH	6	Avant ES 6 / Before SS 6 "Corcieux"	SECTION 3	DISTANCE 38,70 km	PAGE 77
CH	6A	Assistance IN			
EPREUVE SPECIALE / SPECIAL STAGE			VITESSE MOYENNE / AVERAGE SPEED	TEMPS IMPARTI / TARGET TIME	
ES/SS	6	"Corcieux"	20,00 km	42,39 km/h	00h55min

DISTANCE		DIRECTIONS	INFORMATIONS	DISTANCE DEGRESSIVE
TOTALE	PARTIELLE			
20,00	0,06		<p>ARRIVEE / FINISH "CORCIEUX" ES / SS 6</p> <p>Au chemin à droite / At the path on the right</p> <div style="border: 1px solid black; padding: 5px; width: fit-content;"> N 48° 9'12.0" E 6°52'51.6" </div>	0,00 18,70
20,24	0,24		<p>!!!</p> <p>RALENTISSEUR / DECELERATOR</p>	18,46
20,69	0,45		<p>STOP</p> <p>POINT STOP "CORCIEUX" ES / SS 6</p> <p>Au croisement / At the crossroad</p> <div style="border: 1px solid black; padding: 5px; width: fit-content;"> N 48° 9'29.3" E 6°52'32.8" </div>	18,01
21,32	0,63		S.I. / N.I.	17,38
21,53	0,21		S.I. / N.I.	17,17

Assistance interdite sur l'ensemble du parcours / Assistance forbidden on the whole course

1er e-RVGE

CH	6	Avant ES 6 / Before SS 6 "Corcieux"	SECTION 3	DISTANCE 38,70 km	PAGE 78
CH	6A	Assistance IN			
EPREUVE SPECIALE / SPECIAL STAGE			VITESSE MOYENNE / AVERAGE SPEED 42,39 km/h	TEMPS IMPARTI / TARGET TIME 00h55min	
ES/SS					

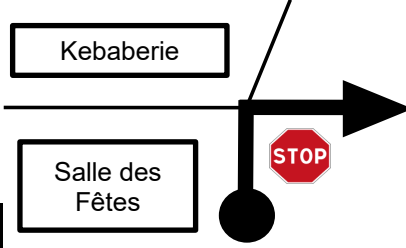
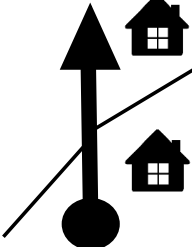
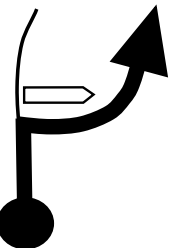
DISTANCE		DIRECTIONS	INFORMATIONS	DISTANCE DEGRESSIVE
TOTALE	PARTIELLE			
22,23	0,70		S.I. / N.I.	16,47
22,38	0,15	<div style="display: flex; flex-direction: column; align-items: center;"> <div style="border: 1px solid black; padding: 2px; margin-bottom: 5px;">Kebaberie</div> <div style="border: 1px solid black; padding: 2px; margin-bottom: 5px;">Salle des Fêtes</div>  </div>	S.I. / N.I.	16,32
		38		
22,55	0,17		S.I. / N.I.	16,15
		39		
23,39	0,84	<div style="text-align: center;"> <div style="background-color: yellow; border: 1px solid black; padding: 2px; margin-bottom: 5px;">D60</div> <div style="border: 1px solid black; padding: 5px; margin-bottom: 5px;">CORCIEUX</div> <div style="border: 1px solid red; border-radius: 50%; width: 30px; height: 30px; display: flex; align-items: center; justify-content: center; margin: 0 auto;">70</div> </div>	SRP / FMR D60	15,31
		40		
23,75	0,36	<div style="display: flex; align-items: center;"> <div style="margin-right: 10px;">!!!</div>  </div>	<div style="text-align: center;"> <div style="background-color: yellow; border: 1px solid black; padding: 2px; margin-bottom: 5px;">D86</div> <div style="border: 1px solid black; padding: 5px; margin-bottom: 5px;">Bellegoutte</div> <div style="border: 1px solid black; padding: 5px;">Rambaville</div> </div>	14,95
		41		

Assistance interdite sur l'ensemble du parcours / Assistance forbidden on the whole course

1er e-RVGE

CH	6	Avant ES 6 / Before SS 6 "Corcieux"	SECTION 3	DISTANCE 38,70 km	PAGE 79
CH	6A	Assistance IN			
EPREUVE SPECIALE / SPECIAL STAGE			VITESSE MOYENNE / AVERAGE SPEED 42,39 km/h	TEMPS IMPARTI / TARGET TIME 00h55min	
ES/SS					

DISTANCE		DIRECTIONS	INFORMATIONS	DISTANCE DEGRESSIVE
TOTALE	PARTIELLE			
24,03	0,28	<div style="text-align: center;"> </div>	S.I. et SRP / N.I. and FMR	14,67
		42		
24,13	0,10	<div style="text-align: center;"> </div>	<div style="text-align: center;"> </div>	14,57
		43	et SRP / and FMR D86	
25,32	1,19	<div style="text-align: center;"> </div>	<div style="text-align: center;"> </div>	13,38
		44		
25,88	0,56	<div style="text-align: center;"> </div>	SRP / FMR D86	12,82
		45		
26,18	0,30	<div style="text-align: center;"> </div>	<div style="text-align: center;"> </div>	12,52
		46	et SRP / and FMR D8	

Assistance interdite sur l'ensemble du parcours / Assistance forbidden on the whole course

1er e-RVGE

CH	6	Avant ES 6 / Before SS 6 "Corcieux"	SECTION 3	DISTANCE 38,70 km	PAGE 80
CH	6A	Assistance IN			
EPREUVE SPECIALE / SPECIAL STAGE			VITESSE MOYENNE / AVERAGE SPEED	TEMPS IMPARTI / TARGET TIME	
ES/SS			42,39 km/h	00h55min	

DISTANCE		DIRECTIONS	INFORMATIONS	DISTANCE DEGRESSIVE
TOTALE	PARTIELLE			
34,42	8,24	<div style="border: 1px solid black; padding: 5px; display: inline-block;">47</div>	<div style="text-align: center; margin-bottom: 5px;">D417</div> <div style="border: 1px solid black; padding: 5px; margin-bottom: 5px; background-color: #90EE90; display: flex; justify-content: space-between;">ÉPINAL 44</div> <div style="border: 1px solid black; padding: 5px; margin-bottom: 5px; display: flex; justify-content: space-between;">GÉRARDMER 3</div>	4,28
35,05	0,63	<div style="border: 1px solid black; padding: 5px; display: inline-block;">48</div>	<div style="text-align: center; margin-bottom: 5px;">D417</div> <div style="border: 1px solid black; padding: 5px; margin-bottom: 5px; background-color: #90EE90; display: flex; justify-content: space-between;">ÉPINAL</div> <div style="border: 1px solid black; padding: 5px; margin-bottom: 5px; display: flex; justify-content: space-between;">GÉRARDMER - <i>CENTRE</i></div>	3,65
35,56	0,51	<div style="border: 1px solid black; padding: 5px; display: inline-block;">49</div> <div style="border: 2px solid red; padding: 5px; text-align: center; margin: 10px auto; width: 150px;">D417 GÉRARDMER</div>	SRP / FMR D417	3,14
36,30	0,74	<div style="border: 1px solid black; padding: 5px; display: inline-block;">50</div>	<div style="text-align: center; margin-bottom: 5px;">D417</div> <div style="border: 1px solid black; padding: 5px; margin-bottom: 5px; background-color: #90EE90; display: flex; justify-content: space-between;">ÉPINAL</div> <div style="border: 1px solid black; padding: 5px; margin-bottom: 5px; display: flex; justify-content: space-between;">CENTRE VILLE</div>	2,40
36,44	0,14	<div style="border: 1px solid black; padding: 5px; display: inline-block;">50</div>	<div style="text-align: center; margin-bottom: 5px;">D417</div> <div style="border: 1px solid black; padding: 5px; margin-bottom: 5px; background-color: #90EE90; display: flex; justify-content: space-between;">ÉPINAL</div> <div style="border: 1px solid black; padding: 5px; margin-bottom: 5px; display: flex; justify-content: space-between;">REMIREMONT LA BRESSE</div> <div style="border: 1px solid black; padding: 5px; margin-bottom: 5px; display: flex; justify-content: space-between;"><i>Coteau des XETTES</i> <i>Halle des Sports</i></div>	2,26

Assistance interdite sur l'ensemble du parcours / Assistance forbidden on the whole course

1er e-RVGE

CH	6	Avant ES 6 / Before SS 6 "Corcieux"	SECTION 3	DISTANCE 38,70 km	PAGE 81
CH	6A	Assistance IN			
EPREUVE SPECIALE / SPECIAL STAGE			VITESSE MOYENNE / AVERAGE SPEED	TEMPS IMPARTI / TARGET TIME	
ES/SS			42,39 km/h	00h55min	

DISTANCE		DIRECTIONS	INFORMATIONS	DISTANCE DEGRESSIVE
TOTALE	PARTIELLE			
37,91	1,47	<div style="text-align: center;"> </div>	S.I. / N.I.	0,79
38,16	0,25	<div style="text-align: center;"> </div>	<div style="text-align: center;"> </div>	0,54
38,32	0,16	<div style="text-align: center;"> </div>	S.I. / N.I.	0,38
38,40	0,08	<div style="text-align: center;"> </div>	<div style="text-align: center;"> </div>	0,30
38,51	0,11	<div style="text-align: center;"> </div>	<div style="text-align: center;"> </div>	0,19

Assistance interdite sur l'ensemble du parcours / Assistance forbidden on the whole course

1er e-RVGE					
CH	6	Avant ES 6 / Before SS 6 "Corcieux"	SECTION	3	PAGE
CH	6A	Assistance IN	DISTANCE	38,70 km	
EPREUVE SPECIALE / SPECIAL STAGE			VITESSE MOYENNE / AVERAGE SPEED	42,39 km/h	82
ES/SS			TEMPS IMPARTI / TARGET TIME	00h55min	
DISTANCE		DIRECTIONS	INFORMATIONS	DISTANCE DEGRESSIVE	
TOTALE	PARTIELLE				
38,64	0,13			0,06	
38,70	0,06		<p>CH 6A Assistance IN</p> <p>N 48°04'13.1" E 6°52'07.9"</p>	0,00	54

SECTION 3 CH 6A

C.H. 6A Assistance IN

N 48°04'13.1" E 6°52'07.9"

1er e-RVGE

CH	6	Avant ES 6 / Before SS 6 "Corcieux"	SECTION 3	DISTANCE 38,77 km	PAGE 81 BIS
CH	6A	Assistance IN			
EPREUVE SPECIALE / SPECIAL STAGE			VITESSE MOYENNE / AVERAGE SPEED	TEMPS IMPARTI / TARGET TIME	
ES/SS			42,29 km/h	00h55min	

DISTANCE		DIRECTIONS	INFORMATIONS	DISTANCE DEGRESSIVE
TOTALE	PARTIELLE			
38,64	0,13			0,16
38,71	0,07		S.I. / N.I.	0,09
38,80	0,09			0,00

54





SECTION 3 CH 6A

C.H. 6A Assistance IN

N 48° 4'12.2" E 6°52'4.7"



1er e-RVGE

CH	-	-	SECTION 3	DISTANCE 0,00 km	PAGE 82 BIS
CH	6B	Assistance OUT & Parc Fermé & Recharge IN			
EPREUVE SPECIALE / SPECIAL STAGE			VITESSE MOYENNE / AVERAGE SPEED -	TEMPS IMPARTI / TARGET TIME 00h45min	
ES/SS					

DISTANCE		DIRECTIONS	INFORMATIONS	DISTANCE DEGRESSIVE
TOTALE	PARTIELLE			
0,00	0,00	PARK 	<u>Service IN</u>	0,00
0,00	0,00	 PARK 	 <u>CH 6B</u> Assistance OUT & Parc Fermé & Recharge IN  N 48°4'20.1" E 6°52'23.6"	0,00
		1		

1er e-RVGE

CH	6A	Assistance IN	SECTION	DISTANCE	PAGE
CH	-	-	3	0,58 km	
EPREUVE SPECIALE / SPECIAL STAGE			VITESSE MOYENNE / AVERAGE SPEED	TEMPS IMPARTI / TARGET TIME	83
ES/SS					

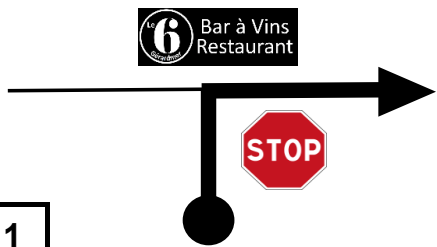
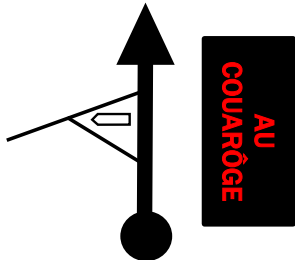
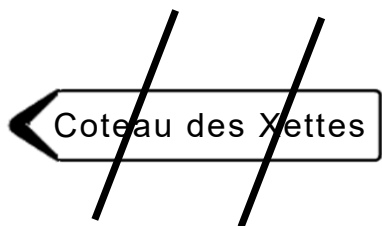
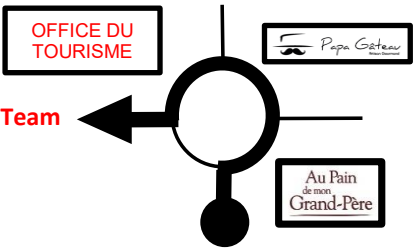



DISTANCE		DIRECTIONS	INFORMATIONS	DISTANCE DEGRESSIVE
TOTALE	PARTIELLE			
0,00	0,00		 <p>CH 6A Assistance IN</p> <div style="border: 1px solid black; padding: 5px; width: fit-content;">  <p>N 48°04'13.1" E 6°52'07.9"</p> </div>	0,58
0,06	0,06		S.I. / N.I.	0,52
0,17	0,11	 <div style="border: 1px solid black; padding: 2px; width: 20px; text-align: center; margin-left: 10px;">1</div>	S.I. et SRP / N.I. and FMR	0,41
0,41	0,24	 <div style="border: 1px solid black; padding: 2px; width: 20px; text-align: center; margin-left: 10px;">3</div>		0,17
0,49	0,08	 <div style="border: 1px solid black; padding: 2px; width: 20px; text-align: center; margin-left: 10px;">4</div>	S.I. / N.I.	0,09

Assistance interdite sur l'ensemble du parcours / Assistance forbidden on the whole course

1er e-RVGE						
CH	6A	Assistance IN		SECTION	DISTANCE	PAGE
CH	-	-		3	0,58 km	
EPREUVE SPECIALE / SPECIAL STAGE				VITESSE MOYENNE / AVERAGE SPEED	TEMPS IMPARTI / TARGET TIME	84
ES/SS						
DISTANCE		DIRECTIONS	INFORMATIONS	DISTANCE		
TOTALE	PARTIELLE			DEGRESSIVE		
0,58	0,09		<u>Service IN</u>	0,00		

1er e-RVGE

CH	-	-	SECTION 3	DISTANCE 0,00 km	PAGE 85
CH	6B	Assistance OUT & Parc Fermé & Recharge IN			
EPREUVE SPECIALE / SPECIAL STAGE			VITESSE MOYENNE / AVERAGE SPEED -	TEMPS IMPARTI / TARGET TIME 00h45min	
ES/SS					

DISTANCE		DIRECTIONS	INFORMATIONS	DISTANCE DEGRESSIVE
TOTALE	PARTIELLE			
0,00	0,00	<p>PARC</p> 	<p><u>Service IN</u></p>	0,00
0,00	0,00	<p>PARC</p>  <p>1</p>	 <p><u>CH 6B</u> Assistance OUT & Parc Fermé & Recharge IN</p>  <p>N 48°4'20.1" E 6°52'23.6"</p>	0,00

ETAPE 2 / LEG 2

1er e-RVGE

Itinéraire et Contrôles / Itinerary and Controls

PAGE
E(2)

Etape 2 - Dimanche 14 juin 2026									
CH ES	Lieux	ES Km	Liaison Km	Total Km	ES Km	Liaison Km	Total Km	Temps imparti	1 ^{er} A290
CH 6C	Départ Etape 2 - Parc Fermé OUT / Assistance IN - Gérardmer		0,66	0,00		0,29	0,29		09:39
ASSISTANCE E - Gérardmer (parking de la prairie / parking du Casino)								00:25	
CH 6D	Assistance OUT - Gérardmer		1,16	1,16		0,29	0,58		10:04
CH 7	RD 50E - Route de Jussarupt (Aumontzey)		16,56	17,72		17,62	18,20	00:25	10:29
ES 7	La Vologne I		0,10	17,82		0,10	18,30	00:03	10:32
	Arrivée ES 7	25,71		43,53	25,71		44,01		
	Point Stop ES 8		0,30	43,83		0,30	44,31		
CH 7A	Recharge IN - Gérardmer		15,46	59,29		15,53	59,84	00:50	11:22
RECHARGE - Gérardmer (parking de la prairie / parking du Casino)								00:38	
CH 7B	Recharge OUT - Gérardmer		1,16	60,45		0,00	59,84		12:00
CH 9	VC 9 - Route de la Chapelle (Gerbamont)		15,97	76,42		17,03	76,87	00:25	12:25
ES 9	Les Trois Cols I		0,06	76,48		0,06	76,93	00:03	12:28
	Arrivée ES 9	14,24		90,72	14,24		91,17		
	Point Stop ES 9		0,32	91,04		0,32	91,49		
CH 9A	Regroupement & Recharge IN - Gérardmer		19,03	110,07		19,10	110,59	00:45	13:13
REGROUPEMENT & RECHARGE - Gérardmer (parking de la prairie / parking du Casino)								02:18	
CH 9B	Regroupement OUT - Assistance IN - Gérardmer		0,58	110,65		0,00	110,59		15:31
ASSISTANCE F - Gérardmer (parking de la prairie / parking du Casino)								01:05	
CH 9C	Assistance OUT - Gérardmer		0,58	110,65		0,00	110,59		16:36
CH 11	VC 1 - Chemin de la Croix de la Houblivière (Rochesson)		12,51	123,16		13,57	124,16	00:25	17:01
ES 11	Le Haut du Tôl II		0,22	123,38		0,22	124,38	00:03	17:04
	Arrivée ES 11	10,92		134,30	10,92		135,30		
	Point Stop ES 11		0,62	134,92		0,62	135,92		
CH11A	Remote Charging AOGSERC IN, Parking Transports Steff					2,69	138,61	00:10	
CH11B	Remote Charging AOGSERC OUT, Parking Transports Steff					0,00	138,61	00:15	
CH 12	VC 9 - Route de la Chapelle (Gerbamont)		8,01	142,93		5,23	143,84	00:35	00:25
ES 12	Les Trois Cols II		0,06	142,99		0,06	143,90	00:03	17:39
	Arrivée ES 12	14,24		157,23	13,60		157,50		17:42
	Point Stop ES 12		0,32	157,55		0,96	158,46		
CH 12A	Repositionnement IN, Gérardmer, place 8 mai 1945		20,07	177,62		20,07	178,53	00:45	18:27
REPOSITIONNEMENT - Gérardmer (place du 8 mai 1945)								00:15	
Convoi en régime de parc fermé jusqu'au podium d'arrivée									
	Podium - Gérardmer, esplanade du lac		1,32	178,94		1,32	179,85		18:42
	Parc Fermé, Gérardmer, quai de Waremme		0,00	178,94		0,00	179,85		
Total Etape 2 - Trophée Alpine A290 Rallye		65,11	115,07	180,18					36%
Total Etape 2 - ADAC Opel GSE Rally Cup					64,47	115,38	179,85		36%

Section 4

Section 5

Timing détaillé Etape 2 / Detailed timing Leg 2

CH	ITINÉRAIRE	DISTANCES		TEMPS		HORAIRES													Moyenne km/h																																																																																																																																																																																																																																																																																																																																																																																																																																																																																																																																																																																																																																																																																																																																																																																																																																																																																																																																																																																																																																																																																							
		KM ES	KM partiel	Temps Imparti	KM total	Orga*	Tricolore	Autoné	VIP	Info spectat	FSSA	Observ.	Volture 000	Volture 00	Volture 00 CFR	Volture 00 CFR	Volture 00 CFR	1 ^{er} CR		150 ^{mm} CFR	Volture 0 ELEC	1 ^{er} ELEC	25 ^{mm} ELEC	Volture 0 VHC	1 ^{er} VHC	10 ^{mm} VHC	Volture 0 VMRS	1 ^{er} VMRS	15 ^{mm} VMRS	Damier																																																																																																																																																																																																																																																																																																																																																																																																																																																																																																																																																																																																																																																																																																																																																																																																																																																																																																																																																																																																																																																																												
DIMANCHE 14 JUIN 2026 : ETAPE 2 - SECTION 3																																																																																																																																																																																																																																																																																																																																																																																																																																																																																																																																																																																																																																																																																																																																																																																																																																																																																																																																																																																																																																																																																																										
CH 6D	Sortie parc fermé - Gérardmer		0.00	285.04	05:30	05:45	06:00	06:10	06:10	06:10	06:25	06:30	06:40	06:50	06:55	07:00	07:05	07:10	07:15	07:20	07:25	07:30	07:35	07:40	07:45	07:50	07:55	08:00	08:05	08:10	08:15	08:20	08:25	08:30	08:35	08:40	08:45	08:50	08:55	09:00	09:05	09:10	09:15	09:20	09:25	09:30	09:35	09:40	09:45	09:50	09:55	10:00	10:05	10:10	10:15	10:20	10:25	10:30	10:35	10:40	10:45	10:50	10:55	11:00	11:05	11:10	11:15	11:20	11:25	11:30	11:35	11:40	11:45	11:50	11:55	12:00	12:05	12:10	12:15	12:20	12:25	12:30	12:35	12:40	12:45	12:50	12:55	13:00	13:05	13:10	13:15	13:20	13:25	13:30	13:35	13:40	13:45	13:50	13:55	14:00	14:05	14:10	14:15	14:20	14:25	14:30	14:35	14:40	14:45	14:50	14:55	15:00	15:05	15:10	15:15	15:20	15:25	15:30	15:35	15:40	15:45	15:50	15:55	16:00	16:05	16:10	16:15	16:20	16:25	16:30	16:35	16:40	16:45	16:50	16:55	17:00	17:05	17:10	17:15	17:20	17:25	17:30	17:35	17:40	17:45	17:50	17:55	18:00	18:05	18:10	18:15	18:20	18:25	18:30	18:35	18:40	18:45	18:50	18:55	19:00	19:05	19:10	19:15	19:20	19:25	19:30	19:35	19:40	19:45	19:50	19:55	20:00	20:05	20:10	20:15	20:20	20:25	20:30	20:35	20:40	20:45	20:50	20:55	21:00	21:05	21:10	21:15	21:20	21:25	21:30	21:35	21:40	21:45	21:50	21:55	22:00	22:05	22:10	22:15	22:20	22:25	22:30	22:35	22:40	22:45	22:50	22:55	23:00	23:05	23:10	23:15	23:20	23:25	23:30	23:35	23:40	23:45	23:50	23:55	24:00	24:05	24:10	24:15	24:20	24:25	24:30	24:35	24:40	24:45	24:50	24:55	25:00	25:05	25:10	25:15	25:20	25:25	25:30	25:35	25:40	25:45	25:50	25:55	26:00	26:05	26:10	26:15	26:20	26:25	26:30	26:35	26:40	26:45	26:50	26:55	27:00	27:05	27:10	27:15	27:20	27:25	27:30	27:35	27:40	27:45	27:50	27:55	28:00	28:05	28:10	28:15	28:20	28:25	28:30	28:35	28:40	28:45	28:50	28:55	29:00	29:05	29:10	29:15	29:20	29:25	29:30	29:35	29:40	29:45	29:50	29:55	30:00	30:05	30:10	30:15	30:20	30:25	30:30	30:35	30:40	30:45	30:50	30:55	31:00	31:05	31:10	31:15	31:20	31:25	31:30	31:35	31:40	31:45	31:50	31:55	32:00	32:05	32:10	32:15	32:20	32:25	32:30	32:35	32:40	32:45	32:50	32:55	33:00	33:05	33:10	33:15	33:20	33:25	33:30	33:35	33:40	33:45	33:50	33:55	34:00	34:05	34:10	34:15	34:20	34:25	34:30	34:35	34:40	34:45	34:50	34:55	35:00	35:05	35:10	35:15	35:20	35:25	35:30	35:35	35:40	35:45	35:50	35:55	36:00	36:05	36:10	36:15	36:20	36:25	36:30	36:35	36:40	36:45	36:50	36:55	37:00	37:05	37:10	37:15	37:20	37:25	37:30	37:35	37:40	37:45	37:50	37:55	38:00	38:05	38:10	38:15	38:20	38:25	38:30	38:35	38:40	38:45	38:50	38:55	39:00	39:05	39:10	39:15	39:20	39:25	39:30	39:35	39:40	39:45	39:50	39:55	40:00	40:05	40:10	40:15	40:20	40:25	40:30	40:35	40:40	40:45	40:50	40:55	41:00	41:05	41:10	41:15	41:20	41:25	41:30	41:35	41:40	41:45	41:50	41:55	42:00	42:05	42:10	42:15	42:20	42:25	42:30	42:35	42:40	42:45	42:50	42:55	43:00	43:05	43:10	43:15	43:20	43:25	43:30	43:35	43:40	43:45	43:50	43:55	44:00	44:05	44:10	44:15	44:20	44:25	44:30	44:35	44:40	44:45	44:50	44:55	45:00	45:05	45:10	45:15	45:20	45:25	45:30	45:35	45:40	45:45	45:50	45:55	46:00	46:05	46:10	46:15	46:20	46:25	46:30	46:35	46:40	46:45	46:50	46:55	47:00	47:05	47:10	47:15	47:20	47:25	47:30	47:35	47:40	47:45	47:50	47:55	48:00	48:05	48:10	48:15	48:20	48:25	48:30	48:35	48:40	48:45	48:50	48:55	49:00	49:05	49:10	49:15	49:20	49:25	49:30	49:35	49:40	49:45	49:50	49:55	50:00	50:05	50:10	50:15	50:20	50:25	50:30	50:35	50:40	50:45	50:50	50:55	51:00	51:05	51:10	51:15	51:20	51:25	51:30	51:35	51:40	51:45	51:50	51:55	52:00	52:05	52:10	52:15	52:20	52:25	52:30	52:35	52:40	52:45	52:50	52:55	53:00	53:05	53:10	53:15	53:20	53:25	53:30	53:35	53:40	53:45	53:50	53:55	54:00	54:05	54:10	54:15	54:20	54:25	54:30	54:35	54:40	54:45	54:50	54:55	55:00	55:05	55:10	55:15	55:20	55:25	55:30	55:35	55:40	55:45	55:50	55:55	56:00	56:05	56:10	56:15	56:20	56:25	56:30	56:35	56:40	56:45	56:50	56:55	57:00	57:05	57:10	57:15	57:20	57:25	57:30	57:35	57:40	57:45	57:50	57:55	58:00	58:05	58:10	58:15	58:20	58:25	58:30	58:35	58:40	58:45	58:50	58:55	59:00	59:05	59:10	59:15	59:20	59:25	59:30	59:35	59:40	59:45	59:50	59:55	60:00	60:05	60:10	60:15	60:20	60:25	60:30	60:35	60:40	60:45	60:50	60:55	61:00	61:05	61:10	61:15	61:20	61:25	61:30	61:35	61:40	61:45	61:50	61:55	62:00	62:05	62:10	62:15	62:20	62:25	62:30	62:35	62:40	62:45	62:50	62:55	63:00	63:05	63:10	63:15	63:20	63:25	63:30	63:35	63:40	63:45	63:50	63:55	64:00	64:05	64:10	64:15	64:20	64:25	64:30	64:35	64:40	64:45	64:50	64:55	65:00	65:05	65:10	65:15	65:20	65:25	65:30	65:35	65:40	65:45	65:50	65:55	66:00	66:05	66:10	66:15	66:20	66:25	66:30	66:35	66:40	66:45	66:50	66:55	67:00	67:05	67:10	67:15	67:20	67:25	67:30	67:35	67:40	67:45	67:50	67:55	68:00	68:05	68:10	68:15	68:20	68:25	68:30	68:35	68:40	68:45	68:50	68:55	69:00	69:05	69:10	69:15	69:20	69:25	69:30	69:35	69:40	69:45	69:50	69:55	70:00	70:05	70:10	70:15	70:20	70:25	70:30	70:35	70:40	70:45	70:50	70:55	71:00	71:05	71:10	71:15	71:20	71:25	71:30	71:35	71:40	71:45	71:50	71:55	72:00	72:05	72:10	72:15	72:20	72:25	72:30	72:35	72:40	72:45	72:50	72:55	73:00	73:05	73:10	73:15	73:20	73:25	73:30	73:35	73:40	73:45	73:50	73:55	74:00	74:05	74:10	74:15	74:20	74:25	74:30	74:35	74:40	74:45	74:50	74:55	75:00	75:05	75:10	75:15	75:20	75:25	75:30	75:35	75:40	75:45	75:50	75:55	76:00	76:05	76:10	76:15	76:20	76:25	76:30	76:35	76:40	76:45	76:50	76:55	77:00	77:05	77:10	77:15	77:20	77:25	77:30	77:35	77:40	77:45	77:50	77:55	78:00	78:05	78:10	78:15	78:20	78:25	78:30	78:35	78:40	78:45	78:50	78:55	79:00	79:05	79:10	79:15	79:20	79:25	79:30	79:35	79:40	79:45	79:50	79:55	80:00	80:05	80:10	80:15	80:20	80:25	80:30	80:35	80:40	80:45	80:50	80:55	81:00	81:05	81:10	81:15	81:20	81:25	81:30	81:35	81:40	81:45	81:50	81:55	82:00	82:05	82:10	82:15	82:20	82:25	82:30	82:35	82:40	82:45	82:50	82:55	83:00	83:05	83:10	83:15	83:20	83:25	83:30	83:35	83:40	83:45	83:50	83:55	84:00	84:05	84:10	84:15	84:20	84:25	84:30	84:35	84:40	84:45	84:50	84:55	85:00	85:05	85:10	85:15	85:20	85:25	85:30	85:35	85:40	85:45	85:50	85:55	86:00	86:05	86:10	86:15	86:20	86:25	86:30	86:35	86:40	86:45	86:50	86:55	87:00	87:05	87:10	87:15	87:20	87:25	87:30	87:35	87:40	87:45	87:50	87:55	88:00	88:05	88:10	88:15	88:20	88:25	88:30	88:35	88:40	88:45	88:50	88:55	89:00	89:05	89:10	89:15	89:20	89:25	89:30	89:35	89:40	89:45	89:50	89:55	90:00	90:05	90:10	90:15	90:20	90:25	90:30	90:35	90:40	90:45	90:50	90:55	91:00	91:05	91:10	91:15	91:20	91:25	91:30	91:35	91:40	91:45	91:50	91:55	92:00	92:05	92:10	92:15	92:20	92:25	92:30	92:35	92:40	92:45	92:50	92:55	93:00	93:05	93:10	93:15	93:20	93:25	93:30	93:35	93:40	93:45	93:50	93:55	94:00	94:05	94:10	94:15	94:20	94:25	94:30

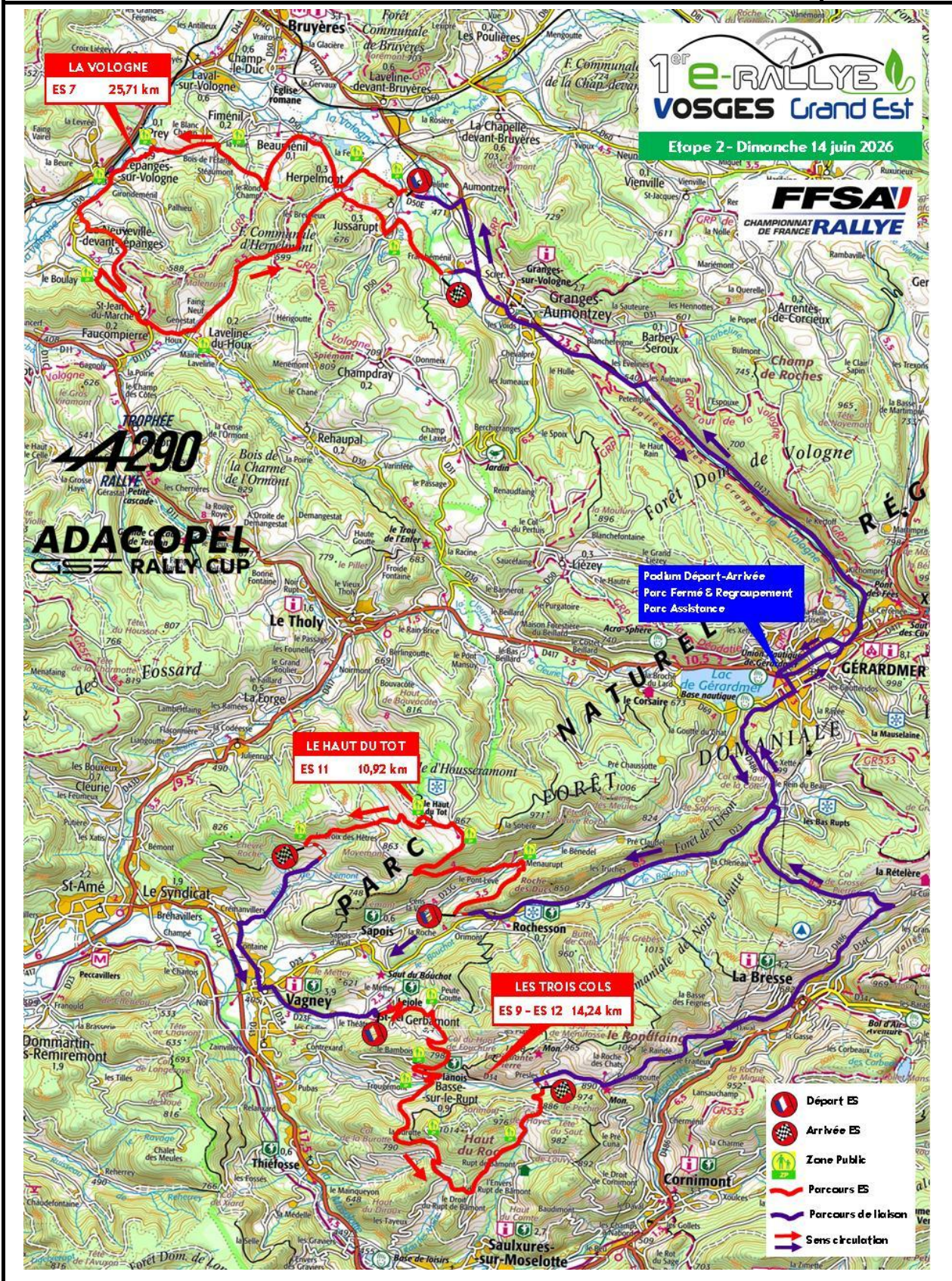





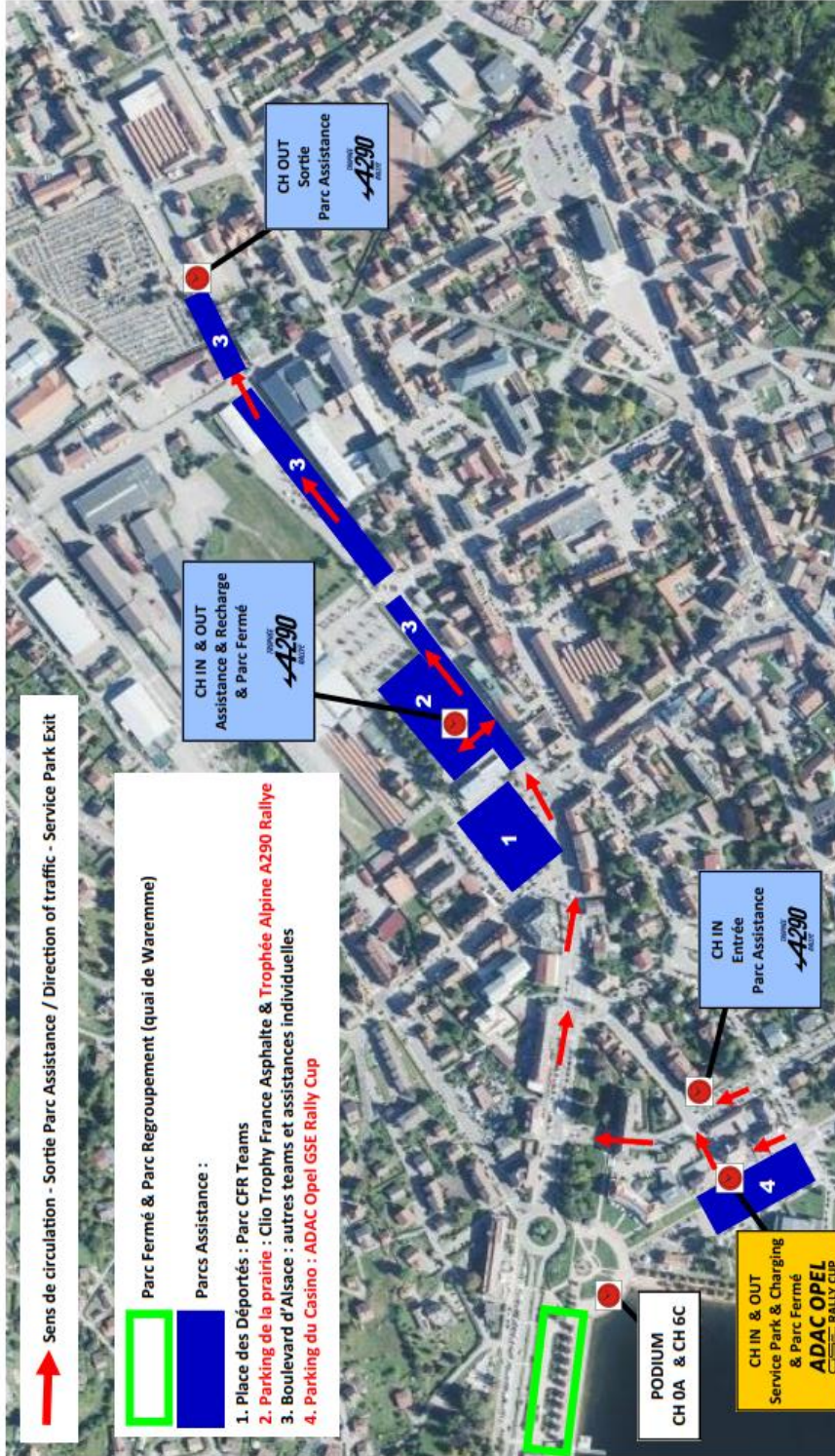

CH PARC ASSISTANCE & PARC FERME
SERVICE PARK & PARC FERME TC

Trophée Alpine A290 Rallye : Parking de la Prairie, Gérardmer
ADAC Opel GSE Rally Cup : Parking du Casino, Gérardmer

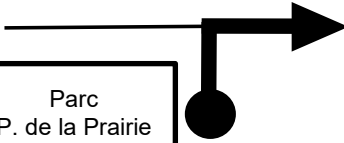

1er e-RVGE

CH	-	-	SECTION 4	DISTANCE 0,66 km	PAGE 88
CH	6C	Parc Fermé OUT / Assistance IN			
EPREUVE SPECIALE / SPECIAL STAGE			VITESSE MOYENNE / AVERAGE SPEED	TEMPS IMPARTI / TARGET TIME	
ES/SS					

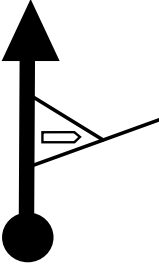
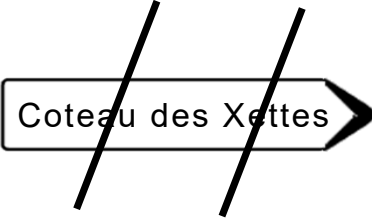
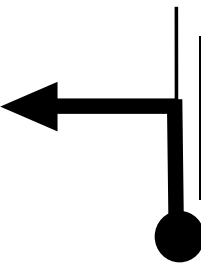
DISTANCE		DIRECTIONS	INFORMATIONS	DISTANCE DEGRESSIVE
TOTALE	PARTIELLE			
0,00	0,00	PARC 	Parc Trophée A290 Rallye  N 48°4'20.1" E 6°52'23.6"	0,66
0,09	0,09	 Parc P. de la Prairie	S.I. / N.I.	0,57
0,14	0,05	 Au Pain de mon Grand-Père Papa Gâteau Parc Team OFFICE DU TOURISME	S.I. / N.I.	0,52
0,22	0,08	 AU COURÂGE 1	 Coteau des Xettes	0,44
0,46	0,24	 6 Bar à Vins Restaurant	S.I. / N.I.	0,20
2				

Assistance interdite sur l'ensemble du parcours / Assistance forbidden on the whole course

1er e-RVGE

CH	-	-	SECTION 4	DISTANCE 0,66 km	PAGE 89
CH	6C	Parc Fermé OUT / Assistance IN			
EPREUVE SPECIALE / SPECIAL STAGE			VITESSE MOYENNE / AVERAGE SPEED	TEMPS IMPARTI / TARGET TIME	
ES/SS					

DISTANCE		DIRECTIONS	INFORMATIONS	DISTANCE DEGRESSIVE
TOTALE	PARTIELLE			
0,51	0,05		S.I. / N.I.	0,15
0,59	0,08		S.I. / N.I.	0,07
0,63	0,04		S.I. / N.I.	0,03
0,66	0,03		<p>CH 6C Parc Fermé OUT / Assistance IN</p> <div style="border: 1px solid black; padding: 2px; display: inline-block;"> N 48° 4'15.4" E 6°52'1.2" </div>	0,00

3

1er e-RVGE

CH	-	-	SECTION	DISTANCE	PAGE
CH	6C	Parc Fermé OUT / Assistance IN	4	0,29 km	
EPREUVE SPECIALE / SPECIAL STAGE			VITESSE MOYENNE / AVERAGE SPEED	TEMPS IMPARTI / TARGET TIME	89 BIS
ES/SS			-	-	

DISTANCE		DIRECTIONS	INFORMATIONS	DISTANCE
TOTALE	PARTIELLE			DEGRESSIVE
0,00	0,00		Sortie Parc Fermé / Exit from the Parc Fermé 	0,29
0,08	0,08		S.I. / N.I.	0,21
0,14	0,06		S.I. / N.I.	0,15
0,22	0,08		S.I. / N.I.	0,07
0,26	0,04		S.I. / N.I.	0,03

1

Assistance interdite sur l'ensemble du parcours / Assistance forbidden on the whole course

1er e-RVGE							
CH	-	-	SECTION	4	DISTANCE	0,29 km	PAGE
CH	6C	Parc Fermé OUT / Assistance IN					
EPREUVE SPECIALE / SPECIAL STAGE			VITESSE MOYENNE / AVERAGE SPEED	-	TEMPS IMPARTI / TARGET TIME	-	90 BIS
ES/SS							
DISTANCE		DIRECTIONS	INFORMATIONS			DISTANCE DEGRESSIVE	
TOTALE	PARTIELLE						
0,29	0,03	<p>PODIUM</p> <p>2</p>	<p>CH 6C Parc Fermé OUT / Assistance IN</p> <div style="border: 1px solid black; padding: 2px; display: inline-block;"> N 48° 4'15.4" E 6°52'1.2" </div>	0,00			







SECTION 4 CH 6C

C.H. 6C Parc Fermé OUT / Service IN

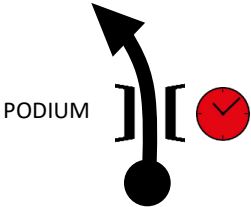
N 48° 4'15.4" E 6°52'1.2"

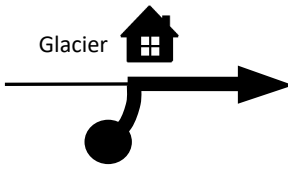
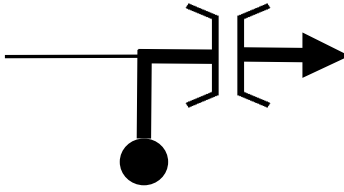
1er e-RVGE

CH	6C	Parc Fermé OUT / Assistance IN	SECTION	DISTANCE	PAGE
CH	6D	Assistance OUT	4	0,29 km	
EPREUVE SPECIALE / SPECIAL STAGE			VITESSE MOYENNE / AVERAGE SPEED	TEMPS IMPARTI / TARGET TIME	91 BIS
ES/SS			-	00h25mn	

DISTANCE		DIRECTIONS	INFORMATIONS	DISTANCE DEGRESSIVE
TOTALE	PARTIELLE			
0,00	0,00	 <p>PODIUM</p>	 <p>CH 6C Parc Fermé OUT / Assistance IN</p> <div style="border: 1px solid black; padding: 2px; width: fit-content; margin: 5px auto;">  <p>N 48° 4'15.4" E 6°52'1.2"</p> </div>	0,29
0,05	0,05	 <p>Glacier</p>	S.I. / N.I.	0,24
0,13	0,08		S.I. / N.I.	0,16
0,20	0,07	 <p style="text-align: center; color: red; font-weight: bold;">Hôtel de la PAIX</p> <p style="text-align: center; color: red; font-weight: bold; font-size: 1.2em;">STOP</p>	S.I. / N.I.	0,09
0,29	0,09	<div style="display: flex; align-items: center; justify-content: center;"> <div style="margin-right: 10px;">  <p>JOACASINO</p> </div> <div style="text-align: center;">  <p>PARK ADAC OPEL RALLY CUP</p> </div> <div style="margin-left: 10px;">  <p style="color: red; font-weight: bold;">Hôtel de la PAIX</p> </div> </div> 	<p style="text-align: center;"><u>ADAC OPEL GSE Rally Cup</u> <u>Assistance Entrance</u></p>	0,00

Assistance interdite sur l'ensemble du parcours / Assistance forbidden on the whole course

1er e-RVGE					
CH	6C	Parc Fermé OUT / Assistance IN	SECTION	DISTANCE	PAGE
CH	6D	Assistance OUT	4	0,29 km	
EPREUVE SPECIALE / SPECIAL STAGE			VITESSE MOYENNE / AVERAGE SPEED	TEMPS IMPARTI / TARGET TIME	92 BIS
ES/SS			-	00h25mn	
DISTANCE		DIRECTIONS	INFORMATIONS	DISTANCE DEGRESSIVE	
TOTALE	PARTIELLE			0,00	0,00

SECTION 1 | CH 0B

C.H. 0B Assistance OUT

N 48° 4'12.2" E 6°52'4.7"

1er e-RVGE

CH	6D	Assistance OUT	SECTION	DISTANCE	PAGE
CH	7	Avant ES 7 "Vologne" / Before SS 7 "Vologne"	4	17,62 km	
EPREUVE SPECIALE / SPECIAL STAGE			VITESSE MOYENNE / AVERAGE SPEED	TEMPS IMPARTI / TARGET TIME	93 BIS
ES/SS			42,29 km/h	00h25mn	

DISTANCE		DIRECTIONS	INFORMATIONS	DISTANCE
TOTALE	PARTIELLE			DEGRESSIVE
0,00	0,00		<p>CH 6D Assistance OUT</p> <div style="border: 1px solid black; padding: 2px; display: inline-block;"> N 48° 4'15.4" E 6°52'1.2" </div>	17,62
0,08	0,08		S.I. / N.I.	17,54
0,19	0,11	<div style="border: 1px solid black; padding: 2px; display: inline-block;">6 Bar à Vins Restaurant</div> 	S.I. / N.I.	17,43
0,43	0,24			17,19
0,51	0,08		puis reprendre / then resume Case 5 page 92 à / at 0,23 km	17,11

Assistance interdite sur l'ensemble du parcours / Assistance forbidden on the whole course



1er e-RVGE					
CH	6C	Parc Fermé OUT / Assistance IN	SECTION	DISTANCE	PAGE
CH	6D	Assistance OUT	4	1,16 km	
EPREUVE SPECIALE / SPECIAL STAGE			VITESSE MOYENNE / AVERAGE SPEED	TEMPS IMPARTI / TARGET TIME	90
ES/SS			2,78 km/h	00h25mn	

SECTION 4 CH 6C

C.H. 6C Parc Fermé OUT / Assistance IN

 N 48° 4'15.4" E 6°52'1.2"

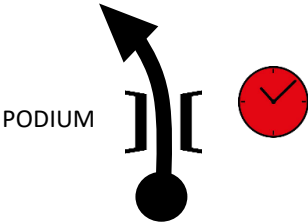

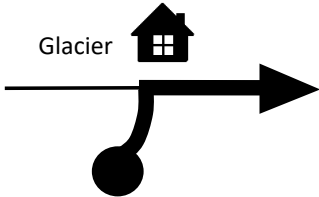
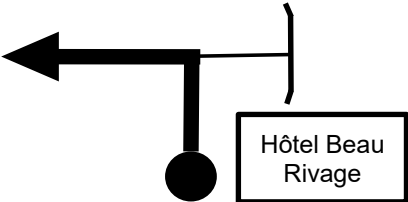
DISTANCE		DIRECTIONS	INFORMATIONS	DISTANCE DEGRESSIVE
TOTALE	PARTIELLE			
0,00	0,00		 CH 6C Parc Fermé OUT / Assistance IN  N 48° 4'15.4" E 6°52'1.2"	1,16
0,05	0,05		S.I. / N.I.	1,11
0,13	0,08		S.I. / N.I.	1,03
		1		

Assistance interdite sur l'ensemble du parcours / Assistance forbidden on the whole course

1er e-RVGE







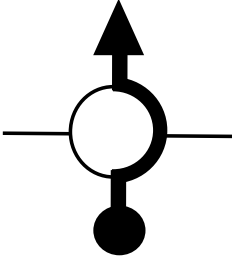

CH	6C	Parc Fermé OUT / Assistance IN	SECTION	DISTANCE	PAGE
CH	6D	Assistance OUT	4	1,16 km	
EPREUVE SPECIALE / SPECIAL STAGE			VITESSE MOYENNE / AVERAGE SPEED	TEMPS IMPARTI / TARGET TIME	91
ES/SS			2,78 km/h	00h25mn	

DISTANCE		DIRECTIONS	INFORMATIONS	DISTANCE DEGRESSIVE
TOTALE	PARTIELLE			
0,18	0,05	<div style="border: 1px solid black; padding: 5px; margin-bottom: 5px;"> Bar à Vins Restaurant </div> <div style="border: 1px solid black; padding: 5px; margin-top: 5px; width: 20px; text-align: center; float: left; margin-right: 5px;">2</div>	S.I. / N.I.	0,98
0,42	0,24	<div style="border: 1px solid black; padding: 5px; margin-top: 5px; width: 20px; text-align: center; float: left; margin-right: 5px;">3</div>		0,74
0,50	0,08		S.I. / N.I.	0,66
0,59	0,09		<p style="text-align: center;"><u>Parc Trophée A290 Rallye</u> <u>Entrée Assistance</u></p>	0,57
0,68	0,09	<div style="border: 1px solid black; padding: 5px; margin-top: 5px; width: 20px; text-align: center; float: left; margin-right: 5px;">4</div>	S.I. / N.I.	0,48

Assistance interdite sur l'ensemble du parcours / Assistance forbidden on the whole course

1er e-RVGE

CH	6C	Parc Fermé OUT / Assistance IN	SECTION 4	DISTANCE 1,16 km	PAGE 92
CH	6D	Assistance OUT			
EPREUVE SPECIALE / SPECIAL STAGE			VITESSE MOYENNE / AVERAGE SPEED 2,78 km/h	TEMPS IMPARTI / TARGET TIME 00h25mn	
ES/SS					

DISTANCE		DIRECTIONS	INFORMATIONS	DISTANCE DEGRESSIVE
TOTALE	PARTIELLE			
0,87	0,19	<div style="border: 1px solid black; padding: 2px; display: inline-block; writing-mode: vertical-rl; transform: rotate(180deg);">LINVOSGES</div> 	S.I. / N.I.	0,29
1,08	0,21	  	S.I. / N.I.	0,08
1,16	0,08	<div style="border: 1px solid black; padding: 2px; display: inline-block; writing-mode: vertical-rl; transform: rotate(180deg);">Cimetière</div>   	 <p>CH 6D Assistance OUT</p> <div style="border: 1px solid black; padding: 2px; display: inline-block;">  N 48°4'28.0" E 6°52'43.1" </div>	0,00

C.H.6D Assistance OUT

 N 48°4'28.0" E 6°52'43.1"



SECTION 4 | CH 6D

1er e-RVGE

CH	6D	Assistance OUT	SECTION	DISTANCE	PAGE
CH	7	Avant ES 7 "Vologne" / Before SS 7 "Vologne"	4	16,56 km	
EPREUVE SPECIALE / SPECIAL STAGE			VITESSE MOYENNE / AVERAGE SPEED	TEMPS IMPARTI / TARGET TIME	93
ES/SS			39,74 km/h	00h25min	

DISTANCE		DIRECTIONS	INFORMATIONS	DISTANCE DEGRESSIVE
TOTALE	PARTIELLE			
0,00	0,00		<p>CH 6D Assistance OUT</p> <p>N 48°4'28.0" E 6°52'43.1"</p>	16,56
0,10	0,10		<p>AUTRES DIRECTIONS</p>	16,46
0,32	0,22		<p>COLMAR</p> <p>BRUYÈRES SAINT - DIÉ</p>	16,24
0,43	0,11		<p>COLMAR</p> <p>BRUYÈRES SAINT - DIÉ</p> <p>XONRUPT - LONGEMER</p>	16,13
0,63	0,20		<p>BRUYERES SAINT - DIE</p> <p>XONRUPT -LONGEMER</p> <p>COLMAR</p>	15,93

Assistance interdite sur l'ensemble du parcours / Assistance forbidden on the whole course

1er e-RVGE









CH	6D	Assistance OUT	SECTION 4	DISTANCE 16,56 km	PAGE 94
CH	7	Avant ES 7 "Vologne" / Before SS 7 "Vologne"			
EPREUVE SPECIALE / SPECIAL STAGE			VITESSE MOYENNE / AVERAGE SPEED 39,74 km/h	TEMPS IMPARTI / TARGET TIME 00h25min	
ES/SS					

DISTANCE		DIRECTIONS	INFORMATIONS	DISTANCE DEGRESSIVE
TOTALE	PARTIELLE			
0,85	0,22		<p>D417</p> <p>COLMAR</p> <p>XONRUPT - LONGEMER</p> <p>SAINT - DIÉ BRUYERES</p>	15,71
0,98	0,13		<p>D423</p> <p>GRANGES ^{s/} V. BRUYÈRES</p> <p>KICHOMPRE LE KERTOFF</p>	15,58
1,10	0,12		S.I. et SRP / N.I. and FMR	15,46
1,50	0,40	<p>4</p>	SRP D423 / FMR D423	15,06
2,48	0,98	<p>5</p>	SRP D423 / FMR D423	14,08
		<p>6</p>		

Assistance interdite sur l'ensemble du parcours / Assistance forbidden on the whole course

1er e-RVGE

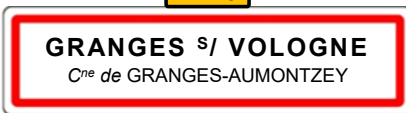
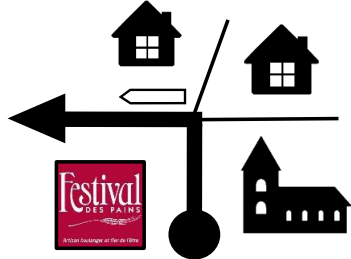
CH	6D	Assistance OUT	SECTION 4	DISTANCE 16,56 km	PAGE 95
CH	7	Avant ES 7 "Vologne" / Before SS 7 "Vologne"			
EPREUVE SPECIALE / SPECIAL STAGE			VITESSE MOYENNE / AVERAGE SPEED	TEMPS IMPARTI / TARGET TIME	
ES/SS			39,74 km/h	00h25min	

DISTANCE		DIRECTIONS	INFORMATIONS	DISTANCE DEGRESSIVE
TOTALE	PARTIELLE			
3,38	0,90	  7	SRP D423 / FMR D423	13,18
4,07	0,69	  8	SRP D423 / FMR D423	12,49
4,71	0,64	  9	SRP D423 / FMR D423	11,85
11,39	6,68	  10	SRP D423 / FMR D423	5,17
12,58	1,19	 11	  et SRP D423 / and FMR D423	3,98

Assistance interdite sur l'ensemble du parcours / Assistance forbidden on the whole course

1er e-RVGE





CH	6D	Assistance OUT	SECTION 4	DISTANCE 16,56 km	PAGE 96
CH	7	Avant ES 7 "Vologne" / Before SS 7 "Vologne"			
EPREUVE SPECIALE / SPECIAL STAGE			VITESSE MOYENNE / AVERAGE SPEED	TEMPS IMPARTI / TARGET TIME	
ES/SS			39,74 km/h	00h25min	

DISTANCE		DIRECTIONS	INFORMATIONS	DISTANCE DEGRESSIVE
TOTALE	PARTIELLE			
13,51	0,93			3,05
13,66	0,15		SRP D423 / FMR D423	2,90
14,92	1,26		SRP D423 / FMR D423	1,64
15,15	0,23		!! ATTENTION RADAR / WARNING RADAR !!	1,41
15,29	0,14			1,27

Assistance interdite sur l'ensemble du parcours / Assistance forbidden on the whole course

1er e-RVGE

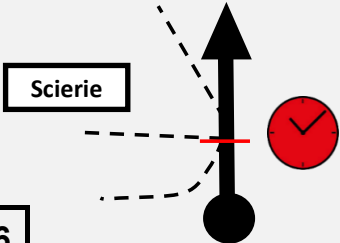
CH	6D	Assistance OUT	SECTION	DISTANCE	PAGE
CH	7	Avant ES 7 "Vologne" / Before SS 7 "Vologne"	4	16,56 km	
EPREUVE SPECIALE / SPECIAL STAGE			VITESSE MOYENNE / AVERAGE SPEED	TEMPS IMPARTI / TARGET TIME	97
ES/SS			39,74 km/h	00h25min	

DISTANCE		DIRECTIONS	INFORMATIONS	DISTANCE DEGRESSIVE
TOTALE	PARTIELLE			
15,95	0,66		SRP D50 ^E / FMR D50 ^E	0,61
		15		
16,46	0,51			0,10
16,56	0,10		<p>CH 7</p> <p>A la scierie à gauche / At the sawmill on the left</p>   <p>N 48°10'6.6" E 6°45'38.8"</p> <p><u>0,10 km avant Départ ES7 "Vologne" /</u> <u>0,10 km before SS7 "Vologne"</u></p>	0,00
		16		

1er e-RVGE

EPREUVE SPECIALE / SPECIAL STAGE

SECTION

4

PAGE

98

ES/SS

7

"VOLOGNE"

25,71 km

1ère / 1st
A290
10h32

C.H. 7



N 48°10'6.6"
E 6°45'38.8"



DEPART / START



N 48°10'8.6"
E 6°45'35.4"

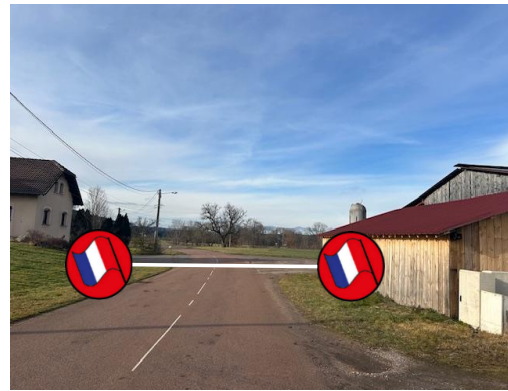

ARRIVEE / FINISH



N 48°9'8.3"
E 6°46'10.7"



POINT STOP



N 48°9'10.2"
E 6°46'25.0"



Fermeture de la route à / Road closure at :

1ère/1st car :

06h00 - 17h30

10h32

99

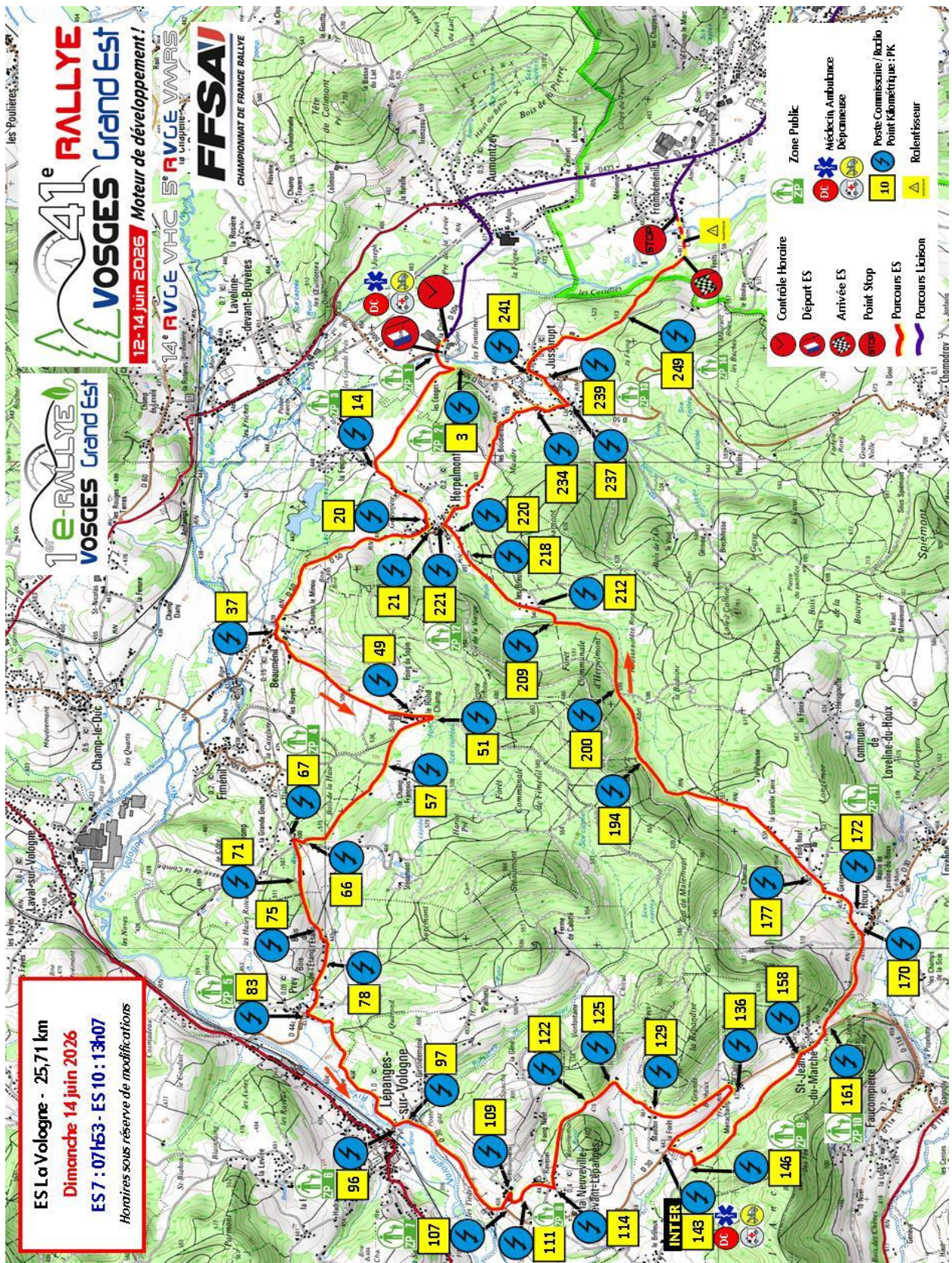

1er e-RVGE







CH	7	Avant ES 7 "Vologne" / Before SS 7 "Vologne"	SECTION	DISTANCE	PAGE
CH	7A	Recharge IN	4	41,47 km	
EPREUVE SPECIALE / SPECIAL STAGE			VITESSE MOYENNE / AVERAGE SPEED	TEMPS IMPARTI / TARGET TIME	100
ES/SS	7	"Vologne"	25,71 km	49,76 km/h	

DISTANCE		DIRECTIONS	INFORMATIONS	DISTANCE DEGRESSIVE
TOTALE	PARTIELLE			25,71
0,00	0,00		<p>DEPART / START "VOLOGNE" ES / SS 7</p> <p>Entre la maison et la ferme / Between the house and the farm</p> <div style="border: 1px solid black; padding: 2px; width: fit-content; margin: 5px auto;"> <p>N 48°10'8.6" E 6°45'35.4"</p> </div>	41,47
0,08	0,08		<div style="border: 1px solid black; padding: 5px; width: fit-content; margin: 5px auto;"> <p style="background-color: yellow; display: inline-block; padding: 2px;">D50D</p></div> <div style="border: 1px solid black; padding: 5px; width: fit-content; margin: 5px auto; text-align: center;"> <p>5 1</p> <p>CHAMPDRAY JUSSARUPT</p> </div>	41,39
0,29	0,21		<div style="border: 1px solid black; padding: 10px; width: fit-content; margin: 5px auto; text-align: center;"> <p>CHEMIN DES CONGES</p> </div>	41,18
1,36	1,07		<p style="text-align: center; font-size: 1.2em;">S.I. / N.I.</p>	40,11
2,03	0,67		<div style="border: 1px solid black; padding: 5px; width: fit-content; margin: 5px auto;"> <p style="background-color: yellow; display: inline-block; padding: 2px;">D50</p></div> <div style="border: 1px solid black; padding: 5px; width: fit-content; margin: 5px auto; text-align: center;"> <p>BEAUMÉNIL 2</p> </div>	39,44

Assistance interdite sur l'ensemble du parcours / Assistance forbidden on the whole course

1er e-RVGE

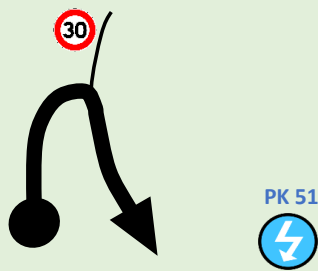
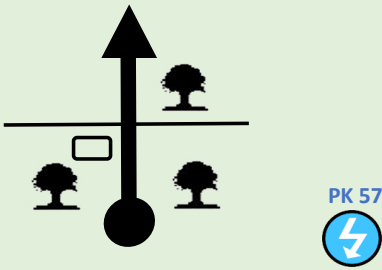
CH	7	Avant ES 7 "Vologne" / Before SS 7 "Vologne"	SECTION	DISTANCE	PAGE
CH	7A	Recharge IN	4	41,47 km	
EPREUVE SPECIALE / SPECIAL STAGE			VITESSE MOYENNE / AVERAGE SPEED	TEMPS IMPARTI / TARGET TIME	101
ES/SS	7	"Vologne"	25,71 km	49,76 km/h	

DISTANCE		DIRECTIONS	INFORMATIONS	DISTANCE DEGRESSIVE
TOTALE	PARTIELLE			
2,26	0,23	 5	SRP / FMR D50	23,45 39,21
3,48	1,22	 6	SRP / FMR D50	22,23 37,99
3,65	0,17	 7	Le Rond Champ Mairie 	22,06 37,82
5,12	1,47	 8	S.I. et SRP / N.I. and FMR	20,59 36,35
5,70	0,58	 9		20,01 35,77

Assistance interdite sur l'ensemble du parcours / Assistance forbidden on the whole course

1er e-RVGE

CH	7	Avant ES 7 "Vologne" / Before SS 7 "Vologne"	SECTION	DISTANCE	PAGE
CH	7A	Recharge IN	4	41,47 km	
EPREUVE SPECIALE / SPECIAL STAGE			VITESSE MOYENNE / AVERAGE SPEED	TEMPS IMPARTI / TARGET TIME	102
ES/SS	7	"Vologne"	25,71 km	49,76 km/h	

DISTANCE		DIRECTIONS	INFORMATIONS	DISTANCE DEGRESSIVE
TOTALE	PARTIELLE			
6,72	1,02		 	18,99 34,75
7,53	0,81		 CHICANE	18,18 33,94
7,81	0,28		 CHICANE	17,90 33,66
8,26	0,45			17,45 33,21
9,55	1,29		S.I. / N.I.	16,16 31,92

Assistance interdite sur l'ensemble du parcours / Assistance forbidden on the whole course

1er e-RVGE



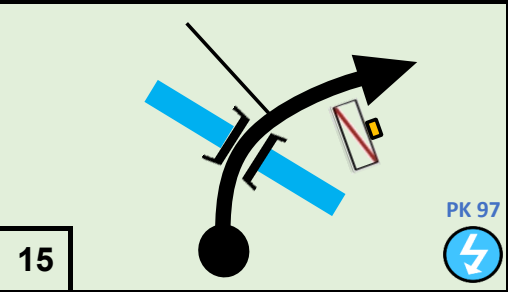
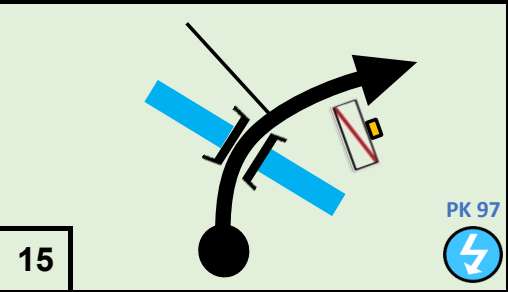
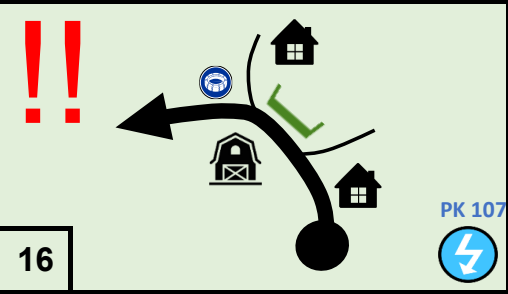
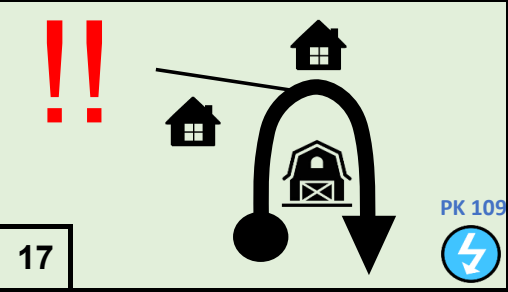
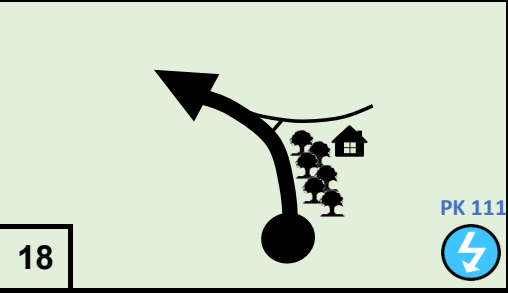
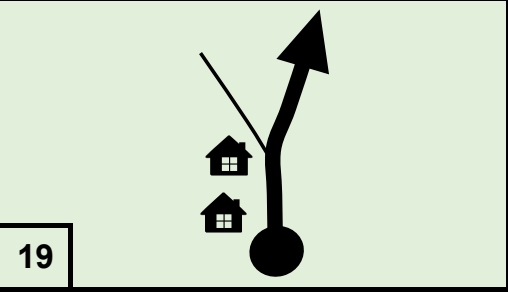

CH	7	Avant ES 7 "Vologne" / Before SS 7 "Vologne"	SECTION	DISTANCE	PAGE 103
CH	7A	Recharge IN	4	41,47 km	
EPREUVE SPECIALE / SPECIAL STAGE			VITESSE MOYENNE / AVERAGE SPEED	TEMPS IMPARTI / TARGET TIME	
ES/SS	7	"Vologne"	25,71 km	49,76 km/h	00h50min

DISTANCE		DIRECTIONS	INFORMATIONS	DISTANCE DEGRESSIVE	
TOTALE	PARTIELLE			16	17
9,65	0,10			16,06	31,82
10,74	1,09		S.I. / N.I.	14,97	30,73
10,91	0,17		S.I. / N.I.	14,80	30,56
11,09	0,18		S.I. et SRP / N.I. and FMR	14,62	30,38
11,28	0,19		S.I. / N.I.	14,43	30,19

Assistance interdite sur l'ensemble du parcours / Assistance forbidden on the whole course

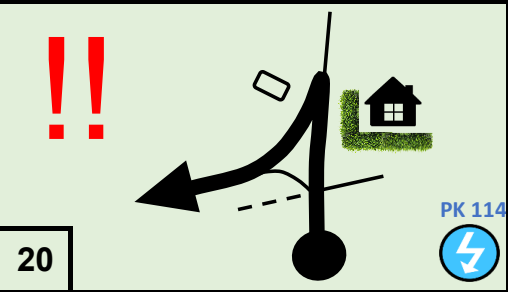
1er e-RVGE

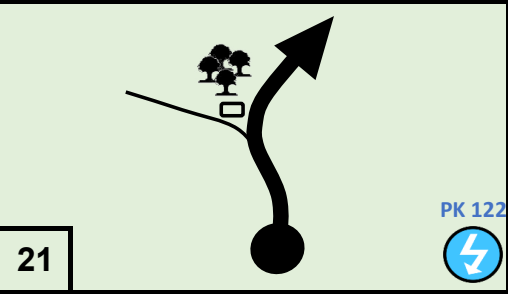
CH	7	Avant ES 7 "Vologne" / Before SS 7 "Vologne"	SECTION	DISTANCE	PAGE
CH	7A	Recharge IN	4	41,47 km	
EPREUVE SPECIALE / SPECIAL STAGE			VITESSE MOYENNE / AVERAGE SPEED	TEMPS IMPARTI / TARGET TIME	104
ES/SS	7	"Vologne"	25,71 km	49,76 km/h	

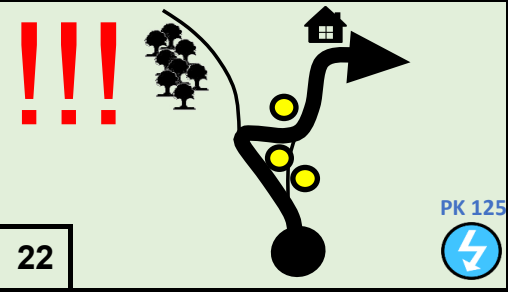
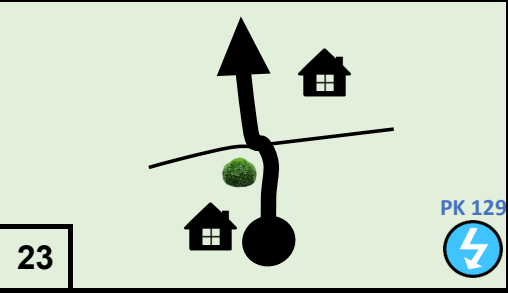
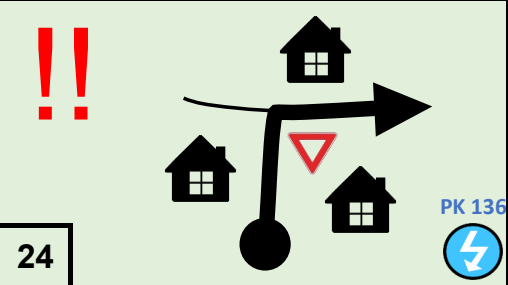
DISTANCE		DIRECTIONS	INFORMATIONS	DISTANCE DEGRESSIVE
TOTALE	PARTIELLE			14,30
11,41	0,13			30,06
12,24	0,83			29,23
12,45	0,21		S.I. / N.I.	29,02
12,90	0,45		S.I. / N.I.	28,57
13,63	0,73		S.I. et SRP / N.I. and FMR	27,84

Assistance interdite sur l'ensemble du parcours / Assistance forbidden on the whole course

1er e-RVGE





CH	7	Avant ES 7 "Vologne" / Before SS 7 "Vologne"	SECTION	DISTANCE	PAGE
CH	7A	Recharge IN	4	41,47 km	
EPREUVE SPECIALE / SPECIAL STAGE			VITESSE MOYENNE / AVERAGE SPEED	TEMPS IMPARTI / TARGET TIME	105
ES/SS	7	"Vologne"	25,71 km	49,76 km/h	

DISTANCE		DIRECTIONS	INFORMATIONS	DISTANCE DEGRESSIVE
TOTALE	PARTIELLE			
14,32	0,69			11,39 27,15
14,59	0,27			11,12 26,88
15,77	1,18		S.I. et SRP / N.I. and FMR	9,94 25,70
16,05	0,28			9,66 25,42
16,11	0,06			9,60 25,36

Assistance interdite sur l'ensemble du parcours / Assistance forbidden on the whole course

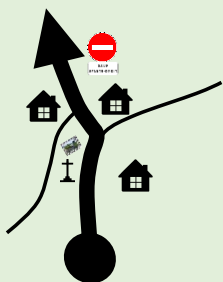
1er e-RVGE

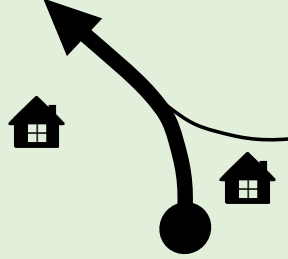
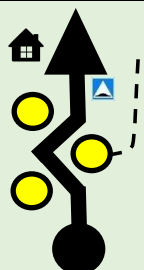
CH	7	Avant ES 7 "Vologne" / Before SS 7 "Vologne"	SECTION	DISTANCE	PAGE
CH	7A	Recharge IN	4	41,47 km	
EPREUVE SPECIALE / SPECIAL STAGE			VITESSE MOYENNE / AVERAGE SPEED	TEMPS IMPARTI / TARGET TIME	106
ES/SS	7	"Vologne"	25,71 km	49,76 km/h	

DISTANCE		DIRECTIONS	INFORMATIONS	DISTANCE DEGRESSIVE
TOTALE	PARTIELLE			
16,89	0,78	<p>D30</p> <p>HOUX Cⁿe de LAVELINE DU HOUX</p> 	SRP / FMR D30	8,82 24,58
16,96	0,07	<p>29</p>  <p>PK 170</p>	 Prendre le sens interdit	8,75 24,51
17,23	0,27	<p>30</p>  <p>PK 172</p>	S.I. et SRP / N.I. and FMR	8,48 24,24
21,10	3,87	<p>C2</p> <p>HERPELMONT</p> <p>31</p>	SRP / FMR C2	4,61 20,37
21,81	0,71	<p>32</p>  <p>PK 218</p>	 CHICANE Au chemin à droite / At the path on the right	3,90 19,66

Assistance interdite sur l'ensemble du parcours / Assistance forbidden on the whole course

1er e-RVGE

CH	7	Avant ES 7 "Vologne" / Before SS 7 "Vologne"	SECTION	DISTANCE	PAGE
CH	7A	Recharge IN	4	41,47 km	
EPREUVE SPECIALE / SPECIAL STAGE			VITESSE MOYENNE / AVERAGE SPEED	TEMPS IMPARTI / TARGET TIME	107
ES/SS	7	"Vologne"	25,71 km	49,76 km/h	

DISTANCE		DIRECTIONS	INFORMATIONS	DISTANCE DEGRESSIVE
TOTALE	PARTIELLE			
22,03	0,22		<p>!!!</p> <p>CHICANE</p> <p>Avant la maison bleue / Before the blue house</p>	3,68 19,44
22,10	0,07		<p>S.I. et SRP / N.I. and FMR</p>	3,61 19,37
22,53	0,43		<p>SRP / FMR D50</p>	3,18 18,94
23,03	0,50		<p>SRP / FMR D50</p>	2,68 18,44
23,42	0,39		<p>SRP / FMR D50</p>	2,29 18,05

Assistance interdite sur l'ensemble du parcours / Assistance forbidden on the whole course

1er e-RVGE

CH	7	Avant ES 7 "Vologne" / Before SS 7 "Vologne"	SECTION	DISTANCE	PAGE
CH	7A	Recharge IN	4	41,47 km	
EPREUVE SPECIALE / SPECIAL STAGE			VITESSE MOYENNE / AVERAGE SPEED	TEMPS IMPARTI / TARGET TIME	108
ES/SS	7	"Vologne"	25,71 km	49,76 km/h	

DISTANCE		DIRECTIONS	INFORMATIONS	DISTANCE DEGRESSIVE
TOTALE	PARTIELLE			TOTAL
23,66	0,24			2,05 17,81
23,93	0,27			1,78 17,54
24,07	0,14			1,64 17,40
24,11	0,04		<p style="text-align: center;">S.I. et SRP / N.I. and FMR</p>	1,60 17,36
24,93	0,82		<p style="text-align: center;">S.I. et SRP / N.I. and FMR</p>	0,78 16,54

Assistance interdite sur l'ensemble du parcours / Assistance forbidden on the whole course

1er e-RVGE











CH	7	Avant ES 7 "Vologne" / Before SS 7 "Vologne"	SECTION	DISTANCE	PAGE
CH	7A	Recharge IN	4	41,47 km	
EPREUVE SPECIALE / SPECIAL STAGE			VITESSE MOYENNE / AVERAGE SPEED	TEMPS IMPARTI / TARGET TIME	109
ES/SS	7	"Vologne"	25,71 km	49,76 km/h	

DISTANCE		DIRECTIONS	INFORMATIONS	DISTANCE DEGRESSIVE
TOTALE	PARTIELLE			0,00
25,71	0,78		<p>ARRIVEE / FINISH "VOLOGNE" ES / SS 7</p> <p>Au croisement à droite / At the crossroad on the right</p> <div style="border: 1px solid black; padding: 5px; width: fit-content; margin: 0 auto;"> <p>N 48°9'8.3" E 6°46'10.7"</p> </div>	15,76
25,83	0,12	<div style="border: 1px solid black; padding: 2px; width: fit-content; margin: 0 auto;">40</div>	<p style="text-align: center; font-size: 2em; color: red;">!!!</p> <p style="text-align: center; color: red;">RALENTISSEUR / DECELERATOR</p>	15,64
26,01	0,18	<div style="border: 1px solid black; padding: 2px; width: fit-content; margin: 0 auto;">41</div>	<p>POINT STOP "VOLOGNE" ES / SS 7</p> <p>Après le rétrécissement de voie / After the lane narrowing</p> <div style="border: 1px solid black; padding: 5px; width: fit-content; margin: 0 auto;"> <p>N 48°9'10.2" E 6°46'25.0"</p> </div>	15,46
26,57	0,56	<div style="border: 1px solid black; padding: 2px; width: fit-content; margin: 0 auto;">42</div>	<p>Sortie Zone Casque / Helmet Area Exit</p>	14,90
27,57	1,00	<div style="border: 1px solid black; padding: 2px; width: fit-content; margin: 0 auto;">43</div>	<div style="border: 1px solid black; padding: 5px; margin: 0 auto;"> <p style="text-align: center; background-color: yellow; display: inline-block;">D423</p></div> <div style="margin-top: 10px;"> <div style="border: 1px solid black; padding: 5px; display: inline-block; margin-right: 10px;"> LE THOLY 14 </div> <div style="border: 1px solid black; padding: 5px; display: inline-block; margin-right: 10px;"> GERARDMER 13 </div> <div style="border: 1px solid black; padding: 5px; display: inline-block;"> <i>Jardins de Berchigranges</i> </div> </div>	13,90

Assistance interdite sur l'ensemble du parcours / Assistance forbidden on the whole course

1er e-RVGE









CH	7	Avant ES 7 "Vologne" / Before SS 7 "Vologne"	SECTION 4	DISTANCE 41,47 km	PAGE 110
CH	7A	Recharge IN			
EPREUVE SPECIALE / SPECIAL STAGE			<small>VITESSE MOYENNE / AVERAGE SPEED</small> 49,76 km/h	<small>TEMPS IMPARTI / TARGET TIME</small> 00h50min	
ES/SS					

DISTANCE		DIRECTIONS	INFORMATIONS	DISTANCE DEGRESSIVE
TOTALE	PARTIELLE			
28,78	1,21	   <div style="border: 1px solid black; padding: 2px; display: inline-block;">44</div>	SRP D423	12,69
30,06	1,28	<div style="background-color: black; color: white; padding: 5px; text-align: center;"> Les Evelines <i>C^{ne} de GRANGES s/ VOLOGNE</i> </div>  <div style="border: 1px solid black; padding: 2px; display: inline-block;">45</div>	SRP D423	11,41
35,44	5,38	  <div style="border: 2px solid red; padding: 5px; text-align: center;"> LE KERTOFF <i>C^{ne} de GÉRARDMER</i> </div> <div style="border: 1px solid black; padding: 2px; display: inline-block;">46</div>	SRP D423	6,03
36,14	0,70	   <div style="border: 1px solid black; padding: 2px; display: inline-block;">47</div>	SRP D423	5,33
36,84	0,70	  <div style="border: 2px solid red; padding: 5px; text-align: center;"> KICHOMPRÉ <i>C^{ne} de GÉRARDMER</i> </div> <div style="border: 1px solid black; padding: 2px; display: inline-block;">48</div>	SRP D423	4,63

Assistance interdite sur l'ensemble du parcours / Assistance forbidden on the whole course

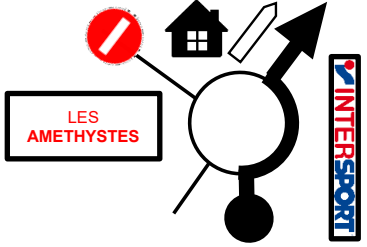
1er e-RVGE

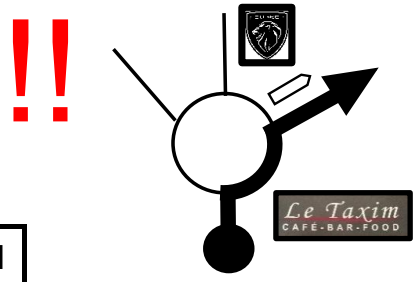

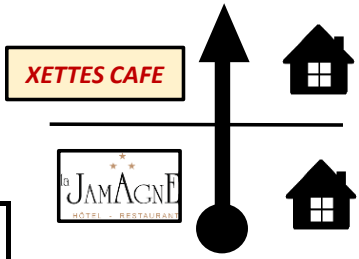

CH	7	Avant ES 7 "Vologne" / Before SS 7 "Vologne"	SECTION	DISTANCE	PAGE
CH	7A	Recharge IN	4	41,47 km	
EPREUVE SPECIALE / SPECIAL STAGE			VITESSE MOYENNE / AVERAGE SPEED	TEMPS IMPARTI / TARGET TIME	111
ES/SS			49,76 km/h	00h50min	

DISTANCE		DIRECTIONS	INFORMATIONS	DISTANCE DEGRESSIVE
TOTALE	PARTIELLE			
37,67	0,83	  49	SRP D423	3,80
38,65	0,98	  50	SRP D423	2,82
39,06	0,41		 D417	2,41
39,20	0,14		 D417	2,27
40,67	1,47		S.I.	0,80

Assistance interdite sur l'ensemble du parcours / Assistance forbidden on the whole course

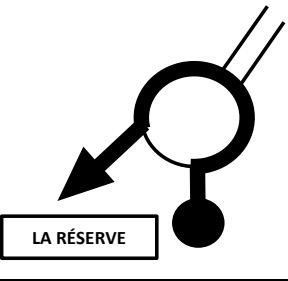
1er e-RVGE

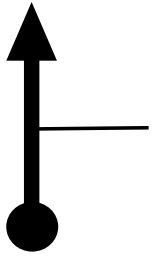
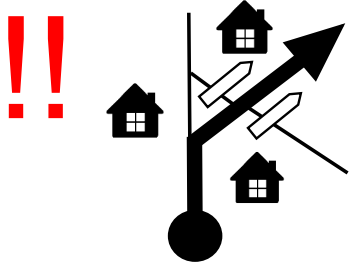
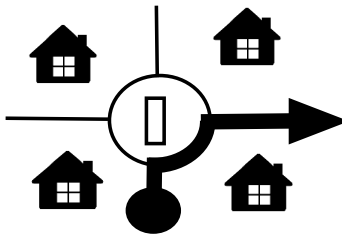
CH	7	Avant ES 7 "Vologne" / Before SS 7 "Vologne"	SECTION	DISTANCE	PAGE 112
CH	7A	Recharge IN	4	41,47 km	
EPREUVE SPECIALE / SPECIAL STAGE			VITESSE MOYENNE / AVERAGE SPEED	TEMPS IMPARTI / TARGET TIME	
ES/SS			49,76 km/h	00h50min	

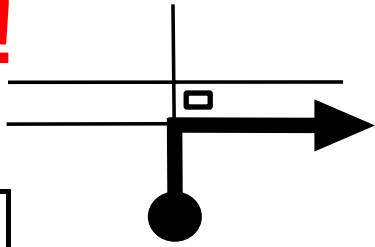
DISTANCE		DIRECTIONS	INFORMATIONS	DISTANCE DEGRESSIVE
TOTALE	PARTIELLE			
40,92	0,25	 <p>53</p>	<p>LA BRESSE</p> <p>CENTRE VILLE</p> <p> Hôpital</p>	0,55
41,08	0,16		S.I.	0,39
41,16	0,08	<p>!!!</p> 	<p>LA BRESSE</p> <p>La Rayée</p> <p>LA BRESSE</p> <p>LA RAYÉE RAMBERCHAMP</p>	0,31
41,27	0,11		<p>S.I. / N.I.</p> <p>ADAC OPEL  112 Bis CSE RALLY CUP</p>	0,20
41,40	0,13	<p>!!!</p>  <p>54</p>	<p>AVENUE DE LATTRE DE TASSIGNY</p>	0,07

Assistance interdite sur l'ensemble du parcours / Assistance forbidden on the whole course

1er e-RVGE						
CH	7	Avant ES 7 "Vologne" / Before SS 7 "Vologne"		SECTION	DISTANCE	PAGE 113
CH	7A	Recharge IN		4	41,47 km	
EPREUVE SPECIALE / SPECIAL STAGE				VITESSE MOYENNE / AVERAGE SPEED	TEMPS IMPARTI / TARGET TIME	
ES/SS				49,76 km/h	00h50min	
DISTANCE		DIRECTIONS		INFORMATIONS		DISTANCE DEGRESSIVE
TOTALE	PARTIELLE					
41,47	0,07			CH 7A Recharge IN N 48°04'13.1" E 6°52'07.9"		0,00
		55				

SECTION 4 CH 7A

C.H. 7A Recharge IN

N 48°04'13.1" E 6°52'07.9"

1er e-RVGE

CH	7	Avant ES 7 "Vologne" / Before SS 7 "Vologne"	SECTION	DISTANCE	PAGE 112BIS
CH	7A	Recharge IN	4	41,54 km	
EPREUVE SPECIALE / SPECIAL STAGE			VITESSE MOYENNE / AVERAGE SPEED	TEMPS IMPARTI / TARGET TIME	
ES/SS			49,85 km/h	00h50min	

DISTANCE		DIRECTIONS	INFORMATIONS	DISTANCE DEGRESSIVE
TOTALE	PARTIELLE			
38,64	0,13			0,16
38,71	0,07		S.I. / N.I.	0,09
38,80	0,09			0,00

54









SECTION 4 CH 7A

C.H. 7A Recharge IN

N 48° 4'12.2" E 6°52'4.7"

1er e-RVGE





CH	7A	Recharge IN	SECTION 4	DISTANCE 0,00 km	PAGE 113BIS
CH	7B	Recharge OUT			
EPREUVE SPECIALE / SPECIAL STAGE			VITESSE MOYENNE / AVERAGE SPEED	TEMPS IMPARTI / TARGET TIME	
ES/SS			-	00h38min	

DISTANCE		DIRECTIONS	INFORMATIONS	DISTANCE DEGRESSIVE
TOTALE	PARTIELLE			
0,00	0,00	 PARK 	 <u>CH 7A</u> Recharge IN  N 48°4'20.1" E 6°52'23.6"	0,00
0,00	0,00	 PARK 	 <u>CH 7B</u> Recharge OUT  N 48°4'20.1" E 6°52'23.6"	0,00

1

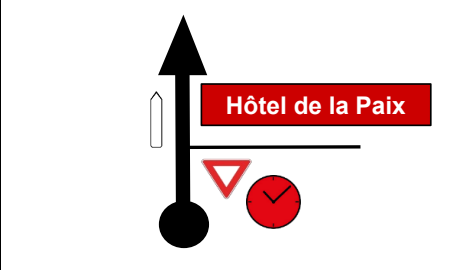
1er e-RVGE

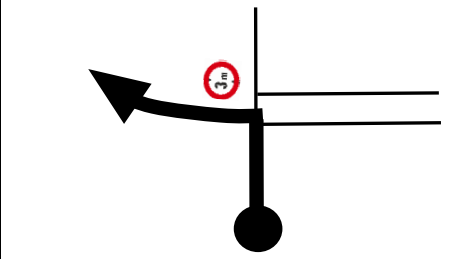
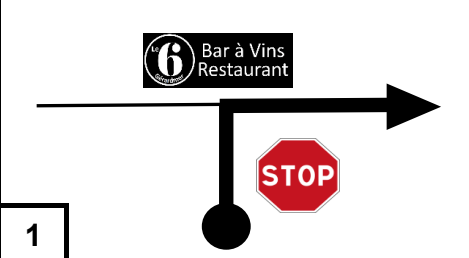
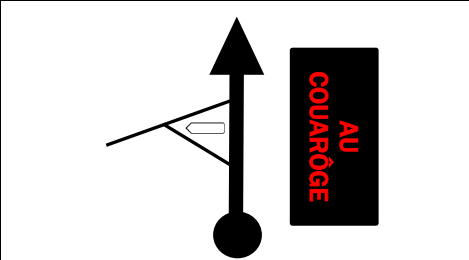
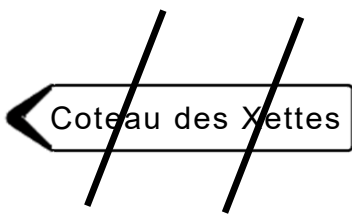

CH	7B	Recharge OUT	SECTION	DISTANCE	PAGE
CH	9	Avant ES9 / Before SS9 "Les Trois Cols"	4	17,03 km	
EPREUVE SPECIALE / SPECIAL STAGE			<small>VITESSE MOYENNE / AVERAGE SPEED</small>	<small>TEMPS IMPARTI / TARGET TIME</small>	114BIS
ES/SS			40,87 km/h	00h25mn	

DISTANCE		DIRECTIONS	INFORMATIONS	DISTANCE DEGRESSIVE
TOTALE	PARTIELLE			
0,00	0,00		 <p style="text-align: center;"><u>CH 7B</u> Recharge OUT</p> <div style="border: 1px solid black; padding: 5px; width: fit-content; margin: 10px auto;">  N 48° 4'15.4" E 6°52'1.2" </div>	17,03
0,08	0,08		S.I. / N.I.	16,95
0,19	0,11	<div style="border: 1px solid black; padding: 2px; width: 20px; margin: 0 auto 10px auto;">1</div> 	S.I. / N.I.	16,84
0,43	0,24			16,60
0,51	0,08	<div style="border: 1px solid black; padding: 2px; width: 20px; margin: 0 auto 10px auto;">2</div> 	<p style="text-align: center;">puis reprendre / then resume</p> <p style="text-align: center; color: red;">Case 2 page 115</p> <p style="text-align: center;">à / at 0,23 km</p>	16,52

Assistance interdite sur l'ensemble du parcours / Assistance forbidden on the whole course

1er e-RVGE

CH	7A	Recharge IN	SECTION 4	DISTANCE 1,16 km	PAGE 114
CH	7B	Recharge OUT			
EPREUVE SPECIALE / SPECIAL STAGE			VITESSE MOYENNE / AVERAGE SPEED -	TEMPS IMPARTI / TARGET TIME 00h38min	
ES/SS					

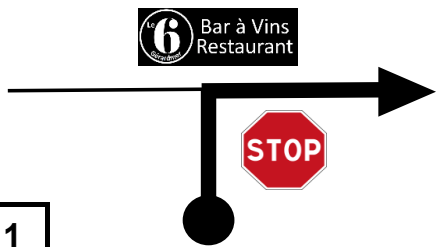
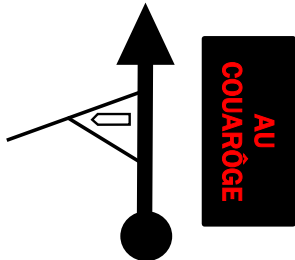
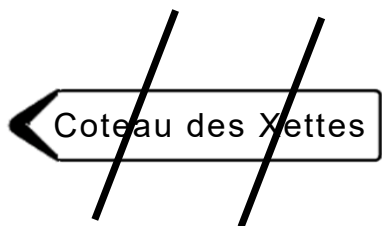
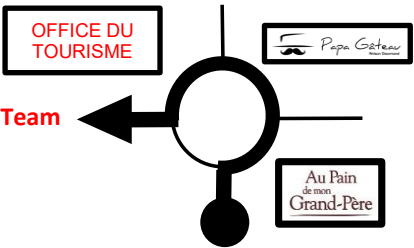
DISTANCE		DIRECTIONS	INFORMATIONS	DISTANCE DEGRESSIVE
TOTALE	PARTIELLE			
0,00	0,00		 <p><u>CH 7A</u> Recharge IN</p> <div style="border: 1px solid black; padding: 2px; width: fit-content;">  N 48°04'13.1" E 6°52'07.9" </div>	1,16
0,06	0,06		S.I. / N.I.	1,10
0,17	0,11	 <div style="border: 1px solid black; padding: 2px; width: 20px; text-align: center; margin-left: 10px;">1</div>	S.I. et SRP / N.I. and FMR	0,99
0,41	0,24	 <div style="border: 1px solid black; padding: 2px; width: 20px; text-align: center; margin-left: 10px;">3</div>		0,75
0,49	0,08	 <div style="border: 1px solid black; padding: 2px; width: 20px; text-align: center; margin-left: 10px;">4</div>	S.I. / N.I.	0,67

Assistance interdite sur l'ensemble du parcours / Assistance forbidden on the whole course

1er e-RVGE

CH	7A	Recharge IN	SECTION 4	DISTANCE 1,16 km	PAGE 115
CH	7B	Recharge OUT			
EPREUVE SPECIALE / SPECIAL STAGE			VITESSE MOYENNE / AVERAGE SPEED -	TEMPS IMPARTI / TARGET TIME 00h38min	
ES/SS					

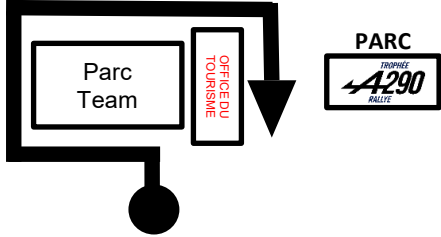
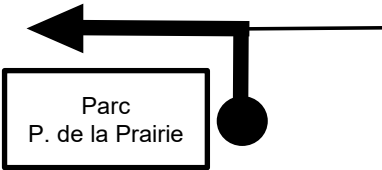
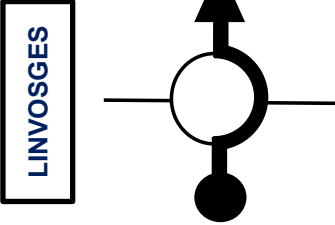
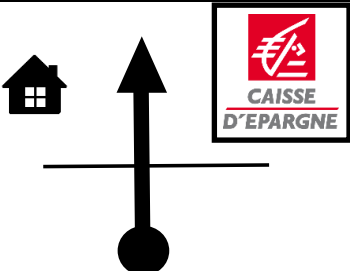
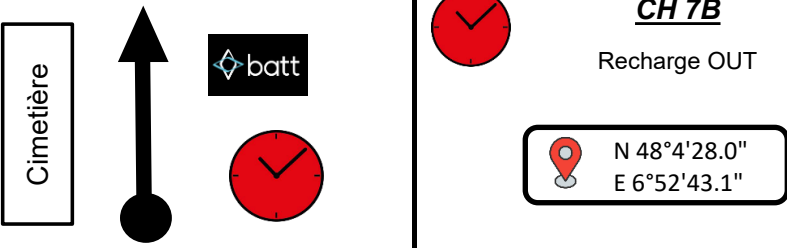
DISTANCE		DIRECTIONS	INFORMATIONS	DISTANCE DEGRESSIVE
TOTALE	PARTIELLE			
0,58	0,09		<u>Charging IN</u>	0,58
0,67	0,09		S.I. / N.I.	0,49
0,87	0,20		S.I. / N.I.	0,29
1,08	0,21		S.I. / N.I.	0,08
1,16	0,08		CH 7B Recharge OUT N 48°4'28.0" E 6°52'43.1"	0,00



Assistance interdite sur l'ensemble du parcours / Assistance forbidden on the whole course

1er e-RVGE					
CH	7A	Recharge IN	SECTION 4	DISTANCE 1,16 km	PAGE 116
CH	7B	Recharge OUT			
EPREUVE SPECIALE / SPECIAL STAGE			VITESSE MOYENNE / AVERAGE SPEED	TEMPS IMPARTI / TARGET TIME	
ES/SS			-	00h38min	
DISTANCE		DIRECTIONS	INFORMATIONS	DISTANCE DEGRESSIVE	
TOTALE	PARTIELLE				

SECTION 4	CH 7B
-----------	-------

C.H. 7B Recharge OUT

 N 48°4'28.0" E 6°52'43.1"

1er e-RVGE

CH	7B	Recharge OUT	SECTION	DISTANCE	PAGE
CH	9	Avant ES9 / Before SS9 "Les Trois Cols"	4	15,97 km	
EPREUVE SPECIALE / SPECIAL STAGE			VITESSE MOYENNE / AVERAGE SPEED	TEMPS IMPARTI / TARGET TIME	117
ES/SS			38,33 km/h	00h25min	

DISTANCE		DIRECTIONS	INFORMATIONS	DISTANCE DEGRESSIVE
TOTALE	PARTIELLE			
0,00	0,00		<p>CH 7B Charging OUT</p> <div style="border: 1px solid black; padding: 2px; display: inline-block;"> N 48°4'28.0" E 6°52'43.1" </div>	15,97
0,07	0,07		<div style="border: 1px solid black; padding: 2px; display: inline-block; margin-bottom: 5px;"> <i>Maison de la Culture et des Loisirs</i> </div> <div style="border: 1px solid black; padding: 2px; display: inline-block; margin-bottom: 5px;"> <i>Gymnase Didier</i> </div> <div style="border: 1px solid black; padding: 2px; display: inline-block;"> <i>Maison de la Musique</i> </div>	15,90
0,18	0,11		<div style="border: 1px solid black; padding: 2px; display: inline-block; margin-bottom: 5px;"> <i>Hôpital</i> <i>Maisons de Retraite</i> </div> <div style="border: 1px solid black; padding: 2px; display: inline-block;"> <i>La Poste</i> </div>	15,79
0,35	0,17		S.I. / N.I.	15,62
0,60	0,25		S.I. / N.I.	15,37

Assistance interdite sur l'ensemble du parcours / Assistance forbidden on the whole course

1er e-RVGE

CH	7B	Recharge OUT	SECTION	DISTANCE	PAGE 118
CH	9	Avant ES9 / Before SS9 "Les Trois Cols"	4	15,97 km	
EPREUVE SPECIALE / SPECIAL STAGE			VITESSE MOYENNE / AVERAGE SPEED	TEMPS IMPARTI / TARGET TIME	
ES/SS			38,33 km/h	00h25min	

DISTANCE		DIRECTIONS	INFORMATIONS	DISTANCE DEGRESSIVE
TOTALE	PARTIELLE			
0,82	0,22	<p>4</p>	<p>Centre Médico-Social</p> <p><i>Finances Publiques</i> <i>Trésorerie</i></p> <p>P <i>Casino - Pl. du Tilleul</i></p>	15,15
0,99	0,17	<p>5</p>	<p>LA BRESSE</p> <p><i>Gendarmerie</i></p> <p>LA RAYÉE RAMBERCHAMP</p> <p> <i>Campings</i></p>	14,98
1,27	0,28	<p>6</p>	<p>D486</p> <p>LA BRESSE</p> <p>RAMBERCHAMP LES BAS RUPTS</p> <p><i>Casino</i> <i>Gendarmerie</i></p>	14,70
1,89	0,62	<p>7</p>	<p>D486</p> <p>12 LA BRESSE</p> <p>9 ROCHESSON 16 VAGNEY</p> <p>2 LES BAS RUPTS</p>	14,08
2,06	0,17	<p>8</p>	SRP / FMR D486	13,91

Assistance interdite sur l'ensemble du parcours / Assistance forbidden on the whole course

1er e-RVGE







CH	7B	Recharge OUT	SECTION 4	DISTANCE 15,97 km	PAGE 119
CH	9	Avant ES9 / Before SS9 "Les Trois Cols"			
EPREUVE SPECIALE / SPECIAL STAGE			<small>VITESSE MOYENNE / AVERAGE SPEED</small> 38,33 km/h	<small>TEMPS IMPARTI / TARGET TIME</small> 00h25min	
ES/SS					

DISTANCE		DIRECTIONS	INFORMATIONS	DISTANCE DEGRESSIVE
TOTALE	PARTIELLE			
3,29	1,23	<div style="background-color: black; color: white; padding: 5px; text-align: center;"> Les Bas Rupts <i>C^{ne} de GÉRARDMER</i> </div> <div style="border: 1px solid black; width: 20px; height: 20px; margin: 5px auto; text-align: center; line-height: 20px;">9</div>	SRP D486 / FMR D486	12,68
5,00	1,71	<div style="text-align: center;"> </div> <div style="border: 1px solid black; width: 20px; height: 20px; margin: 5px auto; text-align: center; line-height: 20px;">10</div>	<div style="text-align: center;"> <div style="background-color: yellow; border: 1px solid black; padding: 2px; display: inline-block;">D23</div> <div style="border: 1px solid black; padding: 5px; display: inline-block;"> ROCHESSON 6 VAGNEY 13 </div> </div>	10,97
7,96	2,96	<div style="background-color: black; color: white; padding: 5px; text-align: center;"> Les Truches <i>C^{ne} de ROCHESSON</i> </div> <div style="text-align: center; margin: 5px;"> </div> <div style="border: 1px solid black; width: 20px; height: 20px; margin: 5px auto; text-align: center; line-height: 20px;">11</div>	SRP D23 / FMR D23	8,01
10,38	2,42	<div style="background-color: black; color: white; padding: 5px; text-align: center;"> Le Bas des Truches <i>C^{ne} de ROCHESSON</i> </div> <div style="border: 1px solid black; width: 20px; height: 20px; margin: 5px auto; text-align: center; line-height: 20px;">12</div>	SRP D23 / FMR D23	5,59
10,99	0,61	<div style="text-align: center;"> <div style="background-color: yellow; border: 1px solid black; padding: 2px; display: inline-block;">D23</div> <div style="border: 2px solid red; padding: 5px; display: inline-block; color: red; font-weight: bold;">ROCHESSON</div> </div> <div style="border: 1px solid black; width: 20px; height: 20px; margin: 5px auto; text-align: center; line-height: 20px;">13</div>	SRP D23 / FMR D23	4,98

Assistance interdite sur l'ensemble du parcours / Assistance forbidden on the whole course

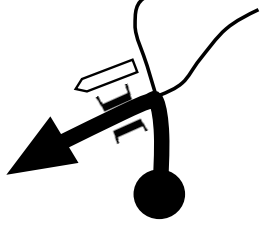
1er e-RVGE





CH	7B	Recharge OUT	SECTION 4	DISTANCE 15,97 km	PAGE 120
CH	9	Avant ES9 / Before SS9 "Les Trois Cols"			
EPREUVE SPECIALE / SPECIAL STAGE			<small>VITESSE MOYENNE / AVERAGE SPEED</small> 38,33 km/h	<small>TEMPS IMPARTI / TARGET TIME</small> 00h25min	
ES/SS					

DISTANCE		DIRECTIONS	INFORMATIONS	DISTANCE DEGRESSIVE
TOTALE	PARTIELLE			
12,55	1,56	<div style="border: 1px solid black; padding: 5px; display: inline-block;"> D23  </div>	SRP D23 / FMR D23	3,42
		14		
14,74	2,19	 	<div style="border: 1px solid black; padding: 5px; display: inline-block;"> D23^F <div style="border: 1px solid black; padding: 2px; margin: 2px;">1.5 GERBAMONT</div> <div style="border: 1px solid black; padding: 2px; margin: 2px;">6 BASSE S/ LE RUPT</div> <div style="border: 1px solid black; padding: 2px; margin: 2px;">0.3  Saut du Bouchot</div> </div>	1,23
		15		
14,95	0,21	 Saut du Bouchot	SRP D23 ^F / FMR D23 ^F	1,02
		16		
15,22	0,27	<div style="border: 1px solid black; padding: 5px; display: inline-block;"> D23^F <div style="border: 2px solid red; padding: 5px; display: inline-block; font-weight: bold;">GERBAMONT</div> </div>	SRP D23 ^F / FMR D23 ^F	0,75
		17		
15,44	0,22	 	<div style="border: 1px solid black; padding: 5px; display: inline-block;"> C9 <div style="border: 1px solid black; padding: 2px; margin-left: 5px;">GERBAMONT -Mairie</div> </div>	0,53
		18		

Assistance interdite sur l'ensemble du parcours / Assistance forbidden on the whole course

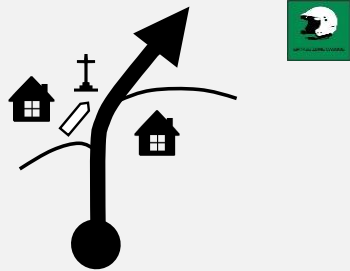
1er e-RVGE

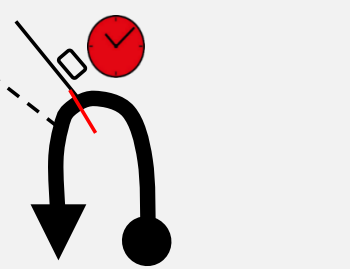
CH	7B	Recharge OUT	SECTION	DISTANCE	PAGE
CH	9	Avant ES9 / Before SS9 "Les Trois Cols"	4	15,97 km	
EPREUVE SPECIALE / SPECIAL STAGE			VITESSE MOYENNE / AVERAGE SPEED	TEMPS IMPARTI / TARGET TIME	121
ES/SS			38,33 km/h	00h25min	

DISTANCE		DIRECTIONS	INFORMATIONS	DISTANCE DEGRESSIVE
TOTALE	PARTIELLE			
15,89	0,45		 Les Plateaux La Cantonne ferme Les Plateaux	0,08
15,97	0,08	 <div style="border: 1px solid black; padding: 2px; display: inline-block;">19</div>	 CH 9 A la route à droite / At the road on the right "IMPASSE DE L'ENVERS" <div style="border: 1px solid black; padding: 5px; display: inline-block;">  N 48°0'9.9" E 6°45'1.9" </div> <small>0,06 km avant Départ ES9 "Les Trois Cols" / 0,06 km before the start of SS9 "Les Trois Cols"</small>	0,00

1er e-RVGE

EPREUVE SPECIALE / SPECIAL STAGE

SECTION

4

PAGE

122

ES/SS

9

"Les Trois Cols"

14,24 km

1ère / 1st
A290

12h28

C.H. 9

N 48°0'9.9"
E 6°45'1.9"



DEPART / START

N 48°0'10.9"
E 6°45'4.6"

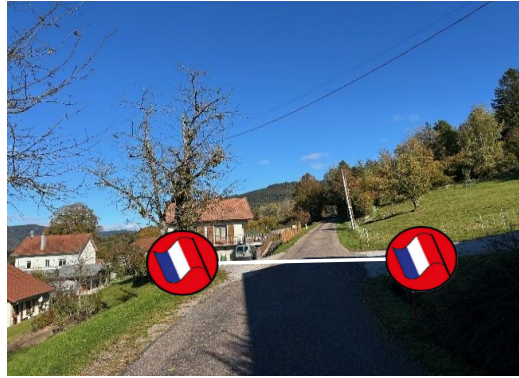

ARRIVEE / FINISH

N 47°59'9.4"
E 6°47'59.7"



POINT STOP

N 47°59'16.9"
E 6°47'51.3"



Fermeture de la route à :

1ère/1st car :

de 08h00 à 20h00

12h28

123

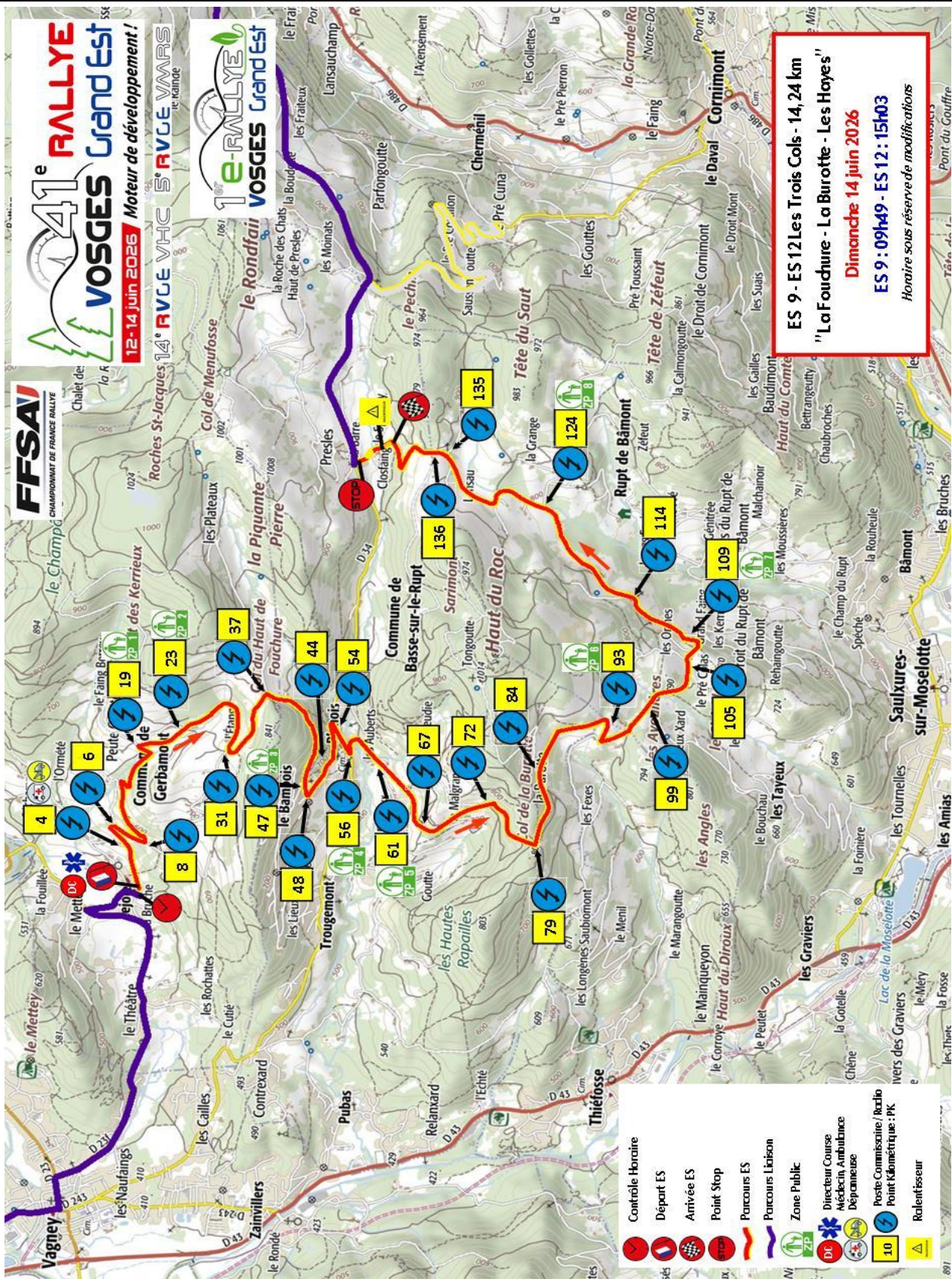

1er e-RVGE









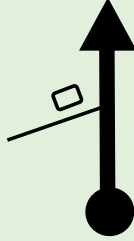

CH	9	Avant ES9 / Before SS9 "Les Trois Cols"	SECTION	DISTANCE	PAGE 124
CH	9A	Regroupement & Recharge IN	4	33,59 km	
EPREUVE SPECIALE / SPECIAL STAGE			VITESSE MOYENNE / AVERAGE SPEED	TEMPS IMPARTI / TARGET TIME	
ES/SS	9	"Les Trois Cols"	14,24 km	44,87 km/h	00h45min

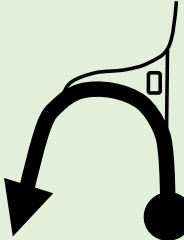
DISTANCE		DIRECTIONS	INFORMATIONS	DISTANCE DEGRESSIVE
TOTALE	PARTIELLE			
0,00	0,00	 1		14,24 33,59
0,38	0,38	 2		13,86 33,21
0,56	0,18	 3		13,68 33,03
0,84	0,28	 4		13,40 32,75
1,87	1,03	 5		12,37 31,72

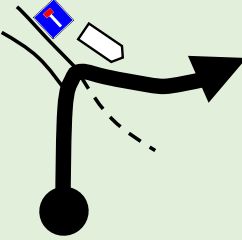
Assistance interdite sur l'ensemble du parcours

1er e-RVGE

CH	9	Avant ES9 / Before SS9 "Les Trois Cols"	SECTION	DISTANCE	PAGE 125
CH	9A	Regroupement & Recharge IN	4	33,59 km	
EPREUVE SPECIALE / SPECIAL STAGE			VITESSE MOYENNE / AVERAGE SPEED	TEMPS IMPARTI / TARGET TIME	
ES/SS	9	"Les Trois Cols"	14,24 km	44,87 km/h	00h45min

DISTANCE		DIRECTIONS	INFORMATIONS	DISTANCE DEGRESSIVE
TOTALE	PARTIELLE			50
2,26	0,39	 <div style="display: flex; justify-content: space-between; align-items: center;"> 6 PK 23 ⚡ </div>	 	11,98 31,33
3,08	0,82	 <div style="display: flex; justify-content: space-between; align-items: center;"> 7 PK 31 ⚡ </div>	 	11,16 30,51
3,71	0,63	 <div style="display: flex; justify-content: space-between; align-items: center;"> 8 PK 37 ⚡ </div>	 	10,53 29,88
3,89	0,18	 <div style="display: flex; justify-content: space-between; align-items: center;"> 9 </div>	 S.I. et SRP / N.I. and FMR	10,35 29,70
4,68	0,79	 <div style="display: flex; justify-content: space-between; align-items: center;"> 10 PK 47 ⚡ </div>	 S.I. et SRP / N.I. and FMR	9,56 28,91

Assistance interdite sur l'ensemble du parcours

1er e-RVGE











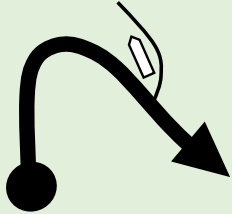



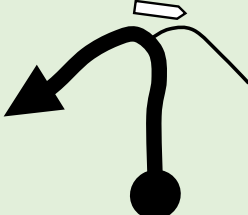





CH	9	Avant ES9 / Before SS9 "Les Trois Cols"	SECTION 4	DISTANCE 33,59 km	PAGE 126
CH	9A	Regroupement & Recharge IN			
EPREUVE SPECIALE / SPECIAL STAGE			VITESSE MOYENNE / AVERAGE SPEED 44,87 km/h	TEMPS IMPARTI / TARGET TIME 00h45min	
ES/SS	9	"Les Trois Cols"	14,24 km		

DISTANCE		DIRECTIONS	INFORMATIONS	DISTANCE DEGRESSIVE
TOTALE	PARTIELLE			
4,76	0,08	 11	 S.I. et SRP / N.I. and FMR	9,48 28,83
5,39	0,63	 12	 S.I. et SRP / N.I. and FMR	8,85 28,20
5,63	0,24	 13	 <div style="border: 1px solid black; padding: 2px; display: inline-block;">La Burotte</div> <div style="border: 1px solid black; padding: 2px; display: inline-block;">La Burotte</div> <div style="border: 1px solid black; padding: 2px; display: inline-block; background-color: #800000; color: white;">étang du Moulin</div>	8,61 27,96
6,11	0,48	 14	 S.I. et SRP / N.I. and FMR	8,13 27,48
7,88	1,77	 15	 <div style="border: 1px solid black; padding: 2px; display: inline-block;">La Burotte</div>	6,36 25,71

Assistance interdite sur l'ensemble du parcours

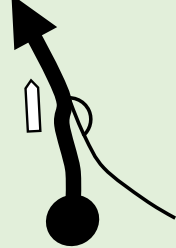
1er e-RVGE

CH	9	Avant ES9 / Before SS9 "Les Trois Cols"	SECTION	DISTANCE	PAGE 127
CH	9A	Regroupement & Recharge IN	4	33,59 km	
EPREUVE SPECIALE / SPECIAL STAGE			VITESSE MOYENNE / AVERAGE SPEED	TEMPS IMPARTI / TARGET TIME	
ES/SS	9	"Les Trois Cols"	14,24 km	44,87 km/h	00h45min

DISTANCE		DIRECTIONS	INFORMATIONS	DISTANCE
TOTALE	PARTIELLE			DEGRESSIVE
9,30	1,42	 <div style="display: flex; justify-content: flex-end; align-items: center; gap: 10px;"> PK 93  </div>	<div style="display: flex; align-items: center; justify-content: center;">  <div style="margin-left: 20px;">  </div> </div>	4,94 24,29
9,42	0,12	 <div style="display: flex; justify-content: flex-end; align-items: center; gap: 10px;"> 16 PK 99  </div>	<div style="display: flex; align-items: center; justify-content: center;">  <div style="margin-left: 20px;">  </div> </div> <div style="margin-top: 10px; font-size: x-small;"> DÉBUT DE ZONE À VITESSE LIMITÉE CONTRÔLÉE </div>	4,82 24,17
9,87	0,45	 <div style="display: flex; justify-content: flex-end; align-items: center; gap: 10px;"> 17 PK 99  </div>	<div style="display: flex; align-items: center; justify-content: center;">  <div style="margin-left: 20px;">  <div style="margin-top: 5px;">  </div> <div style="margin-top: 5px;">  </div> </div> </div> <div style="margin-top: 10px; font-size: x-small;"> DÉBUT DE ZONE À VITESSE LIMITÉE CONTRÔLÉE </div>	4,37 23,72
10,50	0,63	 <div style="display: flex; justify-content: flex-end; align-items: center; gap: 10px;"> 18 PK 105  </div>	<div style="display: flex; align-items: center; justify-content: center;">  <div style="margin-left: 20px;"> S.I. et SRP / N.I. and FMR </div> </div>	3,74 23,09
10,88	0,38	 <div style="display: flex; justify-content: flex-end; align-items: center; gap: 10px;"> 19 PK 109  </div>	<div style="display: flex; align-items: center; justify-content: center;">  <div style="margin-left: 20px;">  <div style="margin-top: 5px;">  </div> </div> </div> <div style="margin-top: 10px; font-size: x-small;"> DÉBUT DE ZONE À VITESSE LIMITÉE CONTRÔLÉE </div>	3,36 22,71

Assistance interdite sur l'ensemble du parcours

1er e-RVGE





CH	9	Avant ES9 / Before SS9 "Les Trois Cols"	SECTION 4	DISTANCE 33,59 km	PAGE 128
CH	9A	Regroupement & Recharge IN			
EPREUVE SPECIALE / SPECIAL STAGE			VITESSE MOYENNE / AVERAGE SPEED 44,87 km/h	TEMPS IMPARTI / TARGET TIME 00h45min	
ES/SS	9	"Les Trois Cols"	14,24 km		

DISTANCE		DIRECTIONS	INFORMATIONS	DISTANCE DEGRESSIVE
TOTALE	PARTIELLE			
12,38	1,50	<p>PK 124</p>	<p>ROUTE DE LANSAU</p> <p>Col de Lansau</p> <p>Col des Hayes</p> <p>Basse sur le Rupt</p>	1,86 21,21
13,50	1,12	<p>PK 135</p>	<p>S.I. et SRP / N.I. and FMR</p>	0,74 20,09
13,60	0,10	<p>PK 136</p>	<p>Haut du Roc</p>	0,64 19,99
14,24	0,64	<p>AES</p>	<p>ARRIVEE / FINISH "LES TROIS COLS" ES 9</p> <p>N 47°59'16.9" E 6°47'51.3"</p>	0,00 19,35
14,36	0,12		<p>RALENTISSEUR / DECELERATOR</p>	19,23

Assistance interdite sur l'ensemble du parcours

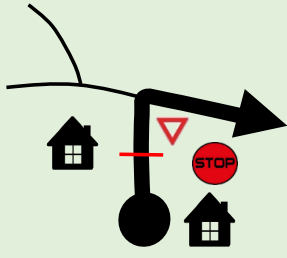
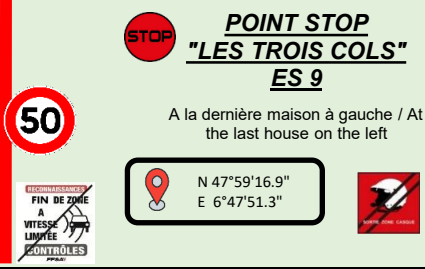
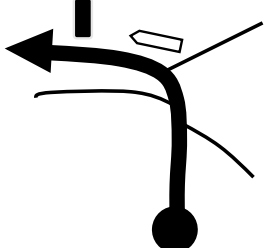









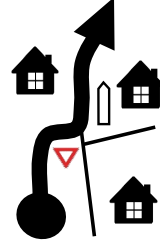

1er e-RVGE

CH	9	Avant ES9 / Before SS9 "Les Trois Cols"	SECTION 4	DISTANCE 33,59 km	PAGE 129
CH	9A	Regroupement & Recharge IN			
EPREUVE SPECIALE / SPECIAL STAGE			VITESSE MOYENNE / AVERAGE SPEED	TEMPS IMPARTI / TARGET TIME	
ES/SS	9	"Les Trois Cols"	14,24 km	44,87 km/h	00h45min

DISTANCE		DIRECTIONS	INFORMATIONS	DISTANCE DEGRESSIVE
TOTALE	PARTIELLE			
14,60	0,24	 25	 18,99	
16,22	1,62	 26	 17,37	
18,43	2,21	 27	SRP / FMR D34 15,16	
19,98	1,55	 28	SRP / FMR D34 13,61	
21,01	1,03	 29	SRP / FMR D34 12,58	

1er e-RVGE

CH	9	Avant ES9 / Before SS9 "Les Trois Cols"	SECTION 4	DISTANCE 33,59 km	PAGE 130
CH	9A	Regroupement & Recharge IN			
EPREUVE SPECIALE / SPECIAL STAGE			VITESSE MOYENNE / AVERAGE SPEED	TEMPS IMPARTI / TARGET TIME	
ES/SS			44,87 km/h	00h45min	

DISTANCE		DIRECTIONS	INFORMATIONS	DISTANCE DEGRESSIVE
TOTALE	PARTIELLE			
21,38	0,37	 	  	12,21
		30		
21,83	0,45	 	SRP / FMR D486	11,76
		31		
26,13	4,30		SRP / FMR D486	7,46
		32		
29,44	3,31		 	4,15
		33		
32,37	2,93	 	SRP / FMR D486	1,22
		34		

Assistance interdite sur l'ensemble du parcours

1er e-RVGE

CH	9	Avant ES9 / Before SS9 "Les Trois Cols"	SECTION 4	DISTANCE 33,59 km	PAGE 131
CH	9A	Regroupement & Recharge IN			
EPREUVE SPECIALE / SPECIAL STAGE			VITESSE MOYENNE / AVERAGE SPEED	TEMPS IMPARTI / TARGET TIME	
ES/SS			44,87 km/h	00h45min	

DISTANCE		DIRECTIONS	INFORMATIONS	DISTANCE DEGRESSIVE
TOTALE	PARTIELLE			
33,16	0,79			0,43
33,40	0,24		<p>S.I. / N.I.</p>	0,19
33,53	0,13			0,06
33,59	0,06			0,00

1er e-RVGE

CH	9	Avant ES9 / Before SS9 "Les Trois Cols"	SECTION 4	DISTANCE 33,59 km	PAGE 132
CH	9A	Regroupement & Recharge IN			
EPREUVE SPECIALE / SPECIAL STAGE			VITESSE MOYENNE / AVERAGE SPEED	TEMPS IMPARTI / TARGET TIME	
ES/SS			44,87 km/h	00h45min	

DISTANCE		DIRECTIONS	INFORMATIONS	DISTANCE DEGRESSIVE
TOTALE	PARTIELLE			

SECTION 4 | CH 9A

C.H. 9A Regroupement & Recharge IN

 N 48°04'13.1" E 6°52'07.9"



1er e-RVGE

CH	9	Avant ES9 / Before SS9 "Les Trois Cols"	SECTION 4	DISTANCE 33,66 km	PAGE 131BIS
CH	9A	Regroupement & Recharge IN			
EPREUVE SPECIALE / SPECIAL STAGE			VITESSE MOYENNE / AVERAGE SPEED	TEMPS IMPARTI / TARGET TIME	
ES/SS			44,87 km/h	00h45min	

DISTANCE		DIRECTIONS	INFORMATIONS	DISTANCE DEGRESSIVE
TOTALE	PARTIELLE			
38,64	0,13			0,16
38,71	0,07		S.I. / N.I.	0,09
38,80	0,09			0,00

54

C.H. 9A Regroupement & Recharge IN





N 48° 4'12.2" E 6°52'4.7"



SECTION 4 CH 9A









1er e-RVGE

CH	9A	Regroupement & Recharge IN	SECTION 4	DISTANCE 0,00 km	PAGE 132BIS
CH	9B	Regroupement OUT - Assistance IN			
EPREUVE SPECIALE / SPECIAL STAGE			<small>VITESSE MOYENNE / AVERAGE SPEED</small> -	<small>TEMPS IMPARTI / TARGET TIME</small> 02h18min	
ES/SS					

DISTANCE		DIRECTIONS	INFORMATIONS	DISTANCE DEGRESSIVE
TOTALE	PARTIELLE			
0,00	0,00	PARK 	<u>Regroupement & Recharge IN</u>	0,00
0,00	0,00	 PARK 	 <u>CH 9B</u> Regroupement OUT - Assistance IN  N 48°4'20.1" E 6°52'23.6"	0,00
		1		





1er e-RVGE

CH	9B	Regroupement OUT - Assistance IN	SECTION 5	DISTANCE 0,00 km	PAGE 133BIS
CH	9C	Assistance OUT			
EPREUVE SPECIALE / SPECIAL STAGE			VITESSE MOYENNE / AVERAGE SPEED -	TEMPS IMPARTI / TARGET TIME 01h05min	
ES/SS					

DISTANCE		DIRECTIONS	INFORMATIONS	DISTANCE DEGRESSIVE
TOTALE	PARTIELLE			
0,00	0,00	 PARK 	 <u>CH 9B</u> Regroupement OUT - Assistance IN  N 48°4'20.1" E 6°52'23.6"	0,00
0,00	0,00	 PARK 	 <u>CH 9C</u> Assistance OUT  N 48°4'20.1" E 6°52'23.6"	0,00
		1		

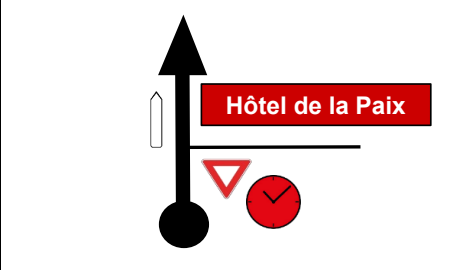
1er e-RVGE

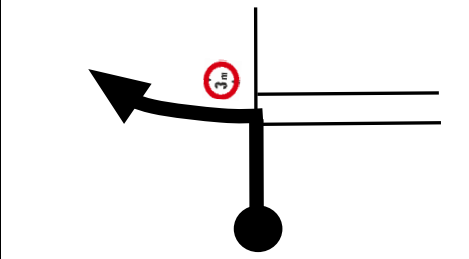
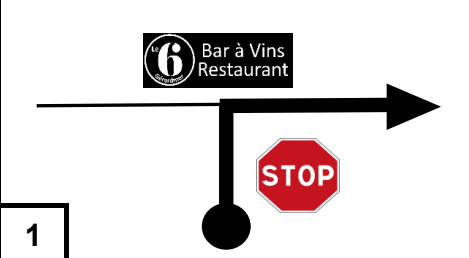
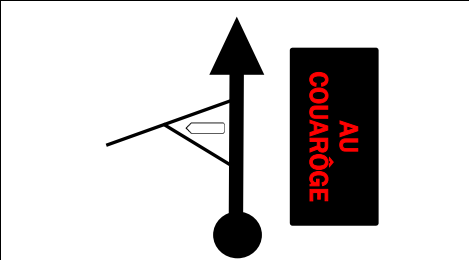

CH	9C	Assistance OUT	SECTION	DISTANCE	PAGE
CH	11	Avant ES 11 / Before SS 11 "Le Haut du Tô't"	5	13,57 km	
EPREUVE SPECIALE / SPECIAL STAGE			VITESSE MOYENNE / AVERAGE SPEED	TEMPS IMPARTI / TARGET TIME	134BIS
ES/SS			-	00h25mn	

DISTANCE		DIRECTIONS	INFORMATIONS	DISTANCE DEGRESSIVE
TOTALE	PARTIELLE			
0,00	0,00		 <p style="text-align: center;"><u>CH 9C</u> Assistance OUT</p> <div style="border: 1px solid black; padding: 5px; width: fit-content; margin: 10px auto;">  N 48° 4'15.4" E 6°52'1.2" </div>	13,57
0,08	0,08		S.I. / N.I.	13,49
0,19	0,11	<div style="border: 1px solid black; padding: 2px; width: fit-content; margin: 0 auto;"> 6 Bar à Vins Restaurant </div> 	S.I. / N.I.	13,38
		1		
0,43	0,24		<div style="border: 1px solid black; padding: 5px; width: fit-content; margin: 0 auto;"> Coteau des Xettes </div>	13,14
0,51	0,08		<p style="text-align: center;">puis reprendre / then resume</p> <p style="text-align: center; color: red; font-weight: bold;">Case 2 page 136</p> <p style="text-align: center;">à / at 0,23 km</p>	13,06
		2		

Assistance interdite sur l'ensemble du parcours / Assistance forbidden on the whole course

1er e-RVGE

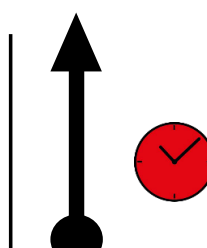
CH	9A	Regroupement & Recharge IN	SECTION	DISTANCE	PAGE 133
CH	-	-	4	0,58 km	
EPREUVE SPECIALE / SPECIAL STAGE			<small>VITESSE MOYENNE / AVERAGE SPEED</small>	<small>TEMPS IMPARTI / TARGET TIME</small>	
ES/SS			-	-	

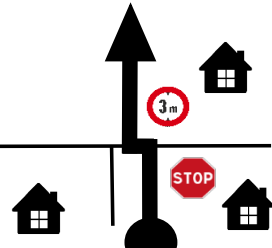
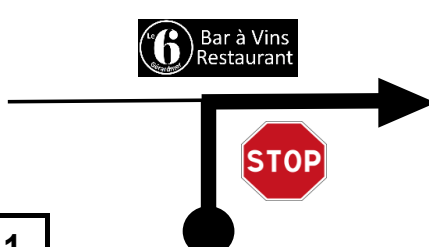
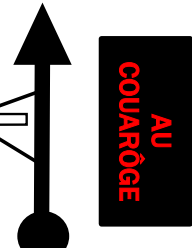
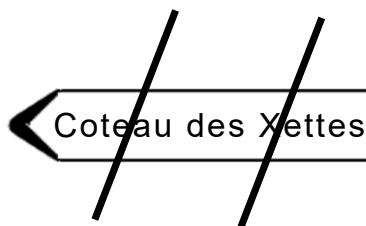
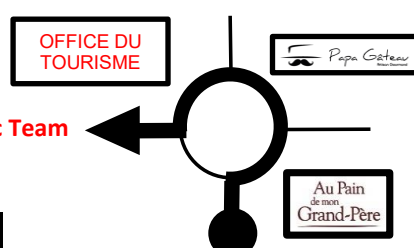



DISTANCE		DIRECTIONS	INFORMATIONS	DISTANCE DEGRESSIVE
TOTALE	PARTIELLE			
0,00	0,00		 <p style="text-align: center;"><u>CH 9A</u> Regroupement & Recharge IN</p> <div style="border: 1px solid black; padding: 5px; width: fit-content; margin: 10px auto;">  N 48°04'13.1" E 6°52'07.9" </div>	0,58
0,06	0,06		S.I. / N.I.	0,52
0,17	0,11	<div style="border: 1px solid black; padding: 2px; width: fit-content; margin: 0 auto;"> 6 Bar à Vins Restaurant </div> 	S.I. et SRP / N.I. and FMR	0,41
0,41	0,24			0,17
0,49	0,08		S.I. / N.I.	0,09

Assistance interdite sur l'ensemble du parcours

1er e-RVGE						
CH	9A	Regroupement & Recharge IN		SECTION	DISTANCE	PAGE
CH	-	-		4	0,58 km	
EPREUVE SPECIALE / SPECIAL STAGE				VITESSE MOYENNE / AVERAGE SPEED	TEMPS IMPARTI / TARGET TIME	134
ES/SS				-	-	
DISTANCE		DIRECTIONS	INFORMATIONS	DISTANCE		
TOTALE	PARTIELLE			DEGRESSIVE		
0,58	0,09		<u>Regroupement & Recharge IN</u>	0,00		







1er e-RVGE

CH	-	-	SECTION 4	DISTANCE 0,00 km	PAGE 135
CH	9B	Regroupement OUT - Assistance IN			
EPREUVE SPECIALE / SPECIAL STAGE			VITESSE MOYENNE / AVERAGE SPEED -	TEMPS IMPARTI / TARGET TIME 02h18min	
ES/SS					

DISTANCE		DIRECTIONS	INFORMATIONS	DISTANCE DEGRESSIVE
TOTALE	PARTIELLE			
0,00	0,00	<p>PARC</p> 	<p><u>Regroupement & Recharge IN</u></p>	0,00
0,00	0,00	<p>PARC</p>  <p>1</p>	<p><u>CH 9B</u></p> <p>Regroupement OUT - Assistance IN - P. de la Prairie</p>   <p>N 48°4'20.1" E 6°52'23.6"</p>	0,00

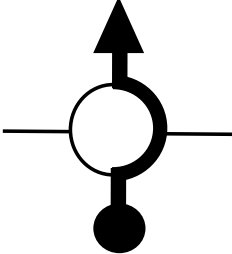
1er e-RVGE

CH	9B	Regroupement OUT - Assistance IN	SECTION 5	DISTANCE 0,58 km	PAGE 136
CH	9C	Assistance OUT			
EPREUVE SPECIALE / SPECIAL STAGE			VITESSE MOYENNE / AVERAGE SPEED -	TEMPS IMPARTI / TARGET TIME 01h05min	
ES/SS					

DISTANCE		DIRECTIONS	INFORMATIONS	DISTANCE DEGRESSIVE
TOTALE	PARTIELLE			
0,00	0,00	 <div style="border: 1px solid black; padding: 5px; margin: 10px auto; width: 150px;"> <p style="text-align: center;">PARC</p> <p style="text-align: center;">TROPHÉE</p> <p style="text-align: center; font-size: 2em; font-weight: bold;">A290</p> <p style="text-align: center;">RALLYE</p> </div>	<p>CH 9B</p> <p>Regroupement OUT - Assistance IN - P. de la Prairie</p> <div style="border: 1px solid black; padding: 5px; margin-top: 10px; width: fit-content;"> <p>N 48°4'20.1" E 6°52'23.6"</p> </div>	0,58
0,09	0,09	 <div style="border: 1px solid black; padding: 5px; margin: 10px auto; width: 100px;"> <p style="text-align: center;">Parc P. de la Prairie</p> </div> <div style="border: 1px solid black; padding: 2px; width: 20px; text-align: center; margin-top: 5px;">1</div>	S.I. / N.I.	0,49
0,29	0,20	<div style="border: 1px solid black; padding: 5px; margin: 10px auto; width: 40px; transform: rotate(-90deg);"> <p style="text-align: center;">LINVOSGES</p> </div>  <div style="border: 1px solid black; padding: 2px; width: 20px; text-align: center; margin-top: 5px;">2</div>	S.I. / N.I.	0,29
0,50	0,21	  <div style="border: 1px solid black; padding: 5px; margin: 10px auto; width: 80px;"> <p style="text-align: center;">CAISSE D'EPARGNE</p> </div>	S.I. / N.I.	0,08
0,58	0,08	<div style="border: 1px solid black; padding: 5px; margin: 10px auto; width: 40px; transform: rotate(-90deg);"> <p style="text-align: center;">Cimetière</p> </div>  <div style="border: 1px solid black; padding: 5px; margin: 10px auto; width: 60px;"> <p style="text-align: center;">batt</p> </div>  <div style="border: 1px solid black; padding: 2px; width: 20px; text-align: center; margin-top: 5px;">3</div>	<p>CH 9C</p> <p>Assistance OUT</p> <div style="border: 1px solid black; padding: 5px; margin-top: 10px; width: fit-content;"> <p>N 48°4'28.0" E 6°52'43.1"</p> </div>	0,00

Assistance interdite sur l'ensemble du parcours

1er e-RVGE					
CH	9B	Regroupement OUT - Assistance IN	SECTION 5	DISTANCE 0,58 km	PAGE 137
CH	9C	Assistance OUT			
EPREUVE SPECIALE / SPECIAL STAGE			VITESSE MOYENNE / AVERAGE SPEED	TEMPS IMPARTI / TARGET TIME	
ES/SS			-	01h05min	
DISTANCE		DIRECTIONS	INFORMATIONS	DISTANCE DEGRESSIVE	
TOTALE	PARTIELLE				

SECTION 5	CH 9C
-----------	-------

C.H. 9C Assistance OUT

 N 48°4'28.0" E 6°52'43.1"



1er e-RVGE

CH	9C	Assistance OUT	SECTION	DISTANCE	PAGE 138
CH	11	Avant ES11 / Before SS11 "Le Haut du Tô't"	5	12,51 km	
EPREUVE SPECIALE / SPECIAL STAGE			VITESSE MOYENNE / AVERAGE SPEED	TEMPS IMPARTI / TARGET TIME	
ES/SS			30,02 km/h	00h25min	

DISTANCE		DIRECTIONS	INFORMATIONS	DISTANCE DEGRESSIVE
TOTALE	PARTIELLE			
0,00	0,00		<p style="text-align: center;">CH 9C Assistance OUT</p> <div style="border: 1px solid black; padding: 5px; width: fit-content; margin: 0 auto;"> N 48°4'28.0" E 6°52'43.1" </div>	12,51
0,07	0,07		<div style="border: 1px solid black; padding: 5px; margin-bottom: 5px;"> <p style="margin: 0;"><i>Maison de la Culture et des Loisirs</i></p> </div> <div style="border: 1px solid black; padding: 5px; margin-bottom: 5px;"> <p style="margin: 0;"><i>Gymnase Didier</i></p> </div> <div style="border: 1px solid black; padding: 5px;"> <p style="margin: 0;"><i>Maison de la Musique</i></p> </div>	12,44
0,18	0,11		<div style="border: 1px solid black; padding: 5px; margin-bottom: 5px;"> <p style="margin: 0;"> <i>Hôpital</i> <i>Maisons de Retraite</i></p> </div> <div style="border: 1px solid black; padding: 5px;"> <p style="margin: 0;"> <i>La Poste</i></p> </div>	12,33
0,35	0,17		S.I. / N.I.	12,16
0,60	0,25		S.I. / N.I.	11,91

Assistance interdite sur l'ensemble du parcours / Assistance forbidden on the whole course

1er e-RVGE



CH	9C	Assistance OUT	SECTION	DISTANCE	PAGE 139
CH	11	Avant ES11 / Before SS11 "Le Haut du Tô't"	5	12,51 km	
EPREUVE SPECIALE / SPECIAL STAGE			VITESSE MOYENNE / AVERAGE SPEED	TEMPS IMPARTI / TARGET TIME	
ES/SS			30,02 km/h	00h25min	

DISTANCE		DIRECTIONS	INFORMATIONS	DISTANCE DEGRESSIVE
TOTALE	PARTIELLE			
0,82	0,22	<p>4</p>	<p>Centre Médico-Social</p> <p>Finances Publiques Trésorerie</p> <p>P Casino - Pl. du Tilleul</p>	11,69
0,99	0,17	<p>5</p>	<p>LA BRESSE</p> <p>Gendarmerie</p> <p>LA RAYÉE RAMBERCHAMP</p> <p>Campings</p>	11,52
1,27	0,28	<p>6</p>	<p>D486</p> <p>LA BRESSE</p> <p>RAMBERCHAMP LES BAS RUPTS</p> <p>Casino Gendarmerie</p>	11,24
1,89	0,62	<p>7</p>	<p>D486</p> <p>12 LA BRESSE</p> <p>9 ROCHESSEON 16 VAGNEY</p> <p>2 LES BAS RUPTS</p>	10,62
2,06	0,17	<p>8</p>	SRP / FMR D486	10,45

Assistance interdite sur l'ensemble du parcours / Assistance forbidden on the whole course

1er e-RVGE

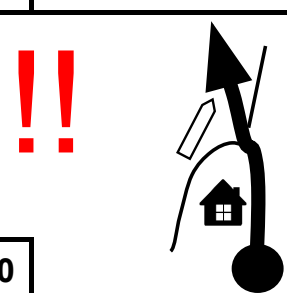
CH	9C	Assistance OUT	SECTION	DISTANCE	PAGE
CH	11	Avant ES11 / Before SS11 "Le Haut du Tô't"	5	12,51 km	
EPREUVE SPECIALE / SPECIAL STAGE			VITESSE MOYENNE / AVERAGE SPEED	TEMPS IMPARTI / TARGET TIME	140
ES/SS			30,02 km/h	00h25min	

DISTANCE		DIRECTIONS	INFORMATIONS	DISTANCE DEGRESSIVE
TOTALE	PARTIELLE			
3,29	1,23	<div style="background-color: black; color: white; padding: 5px; border-radius: 10px; display: inline-block;"> Les Bas Rupts <i>C^{n°} de GÉRARDMER</i> </div>	SRP D486 / FMR D486	9,22
		<div style="border: 1px solid black; padding: 2px; display: inline-block; margin-bottom: 5px;">9</div>		
5,00	1,71		<div style="text-align: center; margin-bottom: 5px;">D23</div> <div style="border: 1px solid black; padding: 5px; display: inline-block;"> ROCHESSON 6 VAGNEY 13 </div>	7,51
		<div style="border: 1px solid black; padding: 2px; display: inline-block; margin-bottom: 5px;">10</div>		
7,96	2,96	<div style="background-color: black; color: white; padding: 5px; border-radius: 10px; display: inline-block;"> Les Truches <i>C^{n°} de ROCHESSON</i> </div> <div style="text-align: center; margin-top: 10px;">  </div>	SRP D23 / FMR D23	4,55
		<div style="border: 1px solid black; padding: 2px; display: inline-block; margin-bottom: 5px;">11</div>		
10,38	2,42	<div style="background-color: black; color: white; padding: 5px; border-radius: 10px; display: inline-block;"> Le Bas des Truches <i>C^{n°} de ROCHESSON</i> </div>	SRP D23 / FMR D23	2,13
		<div style="border: 1px solid black; padding: 2px; display: inline-block; margin-bottom: 5px;">12</div>		
10,99	0,61	<div style="text-align: center; margin-bottom: 5px;">D23</div> <div style="border: 2px solid red; padding: 5px; display: inline-block;"> ROCHESSON </div>	SRP D23 / FMR D23	1,52
		<div style="border: 1px solid black; padding: 2px; display: inline-block; margin-bottom: 5px;">13</div>		

Assistance interdite sur l'ensemble du parcours / Assistance forbidden on the whole course

1er e-RVGE

CH	9C	Assistance OUT	SECTION	DISTANCE	PAGE
CH	11	Avant ES11 / Before SS11 "Le Haut du Tô't"	5	12,51 km	
EPREUVE SPECIALE / SPECIAL STAGE			VITESSE MOYENNE / AVERAGE SPEED	TEMPS IMPARTI / TARGET TIME	141
ES/SS			30,02 km/h	00h25min	

DISTANCE		DIRECTIONS	INFORMATIONS	DISTANCE DEGRESSIVE
TOTALE	PARTIELLE			
12,00	1,01	 14		0,51
12,25	0,25	 15	S.I. et SRP / N.I. and FMR	0,26
12,51	0,26	 16	<p>CH 11</p> <p>Au croisement avec le chemin de la Fesnel / At the intersection with the "Chemin de la Fesnel"</p> <div style="border: 1px solid black; padding: 5px; display: inline-block;"> N 48°1'23.2" E 6°46'59.1" </div> <p><u>0,22 km avant Départ ES11 "Le Haut du Tô't" / 0,22 km before start of ES11 "Le Haut du Tô't"</u></p>	0,00

1er e-RVGE

EPREUVE SPECIALE / SPECIAL STAGE

SECTION

5

PAGE

142

ES/SS

11

"Le Haut du Tô't"

10,92 km

1ère / 1st
A290
17h04

C.H. 11

N 48°1'23.2"
E 6°46'59.1"



DEPART / START

N 48°1'22.5"
E 6°46'24.3"

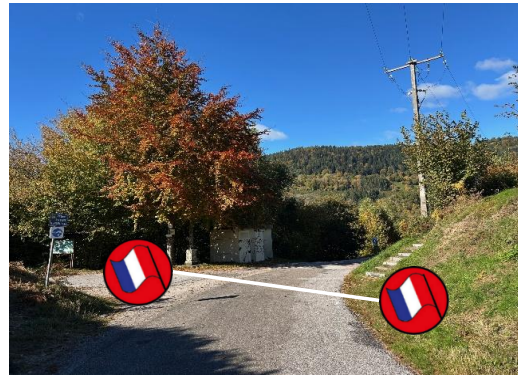

ARRIVEE / FINISH

N 48°2'13.5"
E 6°43'46.2"



POINT STOP

N 48°2'3.7"
E 6°44'3.2"



Fermeture de la route à / Road closure at :

1ère/1st car :

de 07h15 à 19h30

17h04

143

ES 8 - ES 11 Le Haut du Tôt - 10,92 km
Dimanche 14 juin 2026
 ES 8 : 09h11 - ES 11 : 14h25
 Horaire sous réserve de modifications

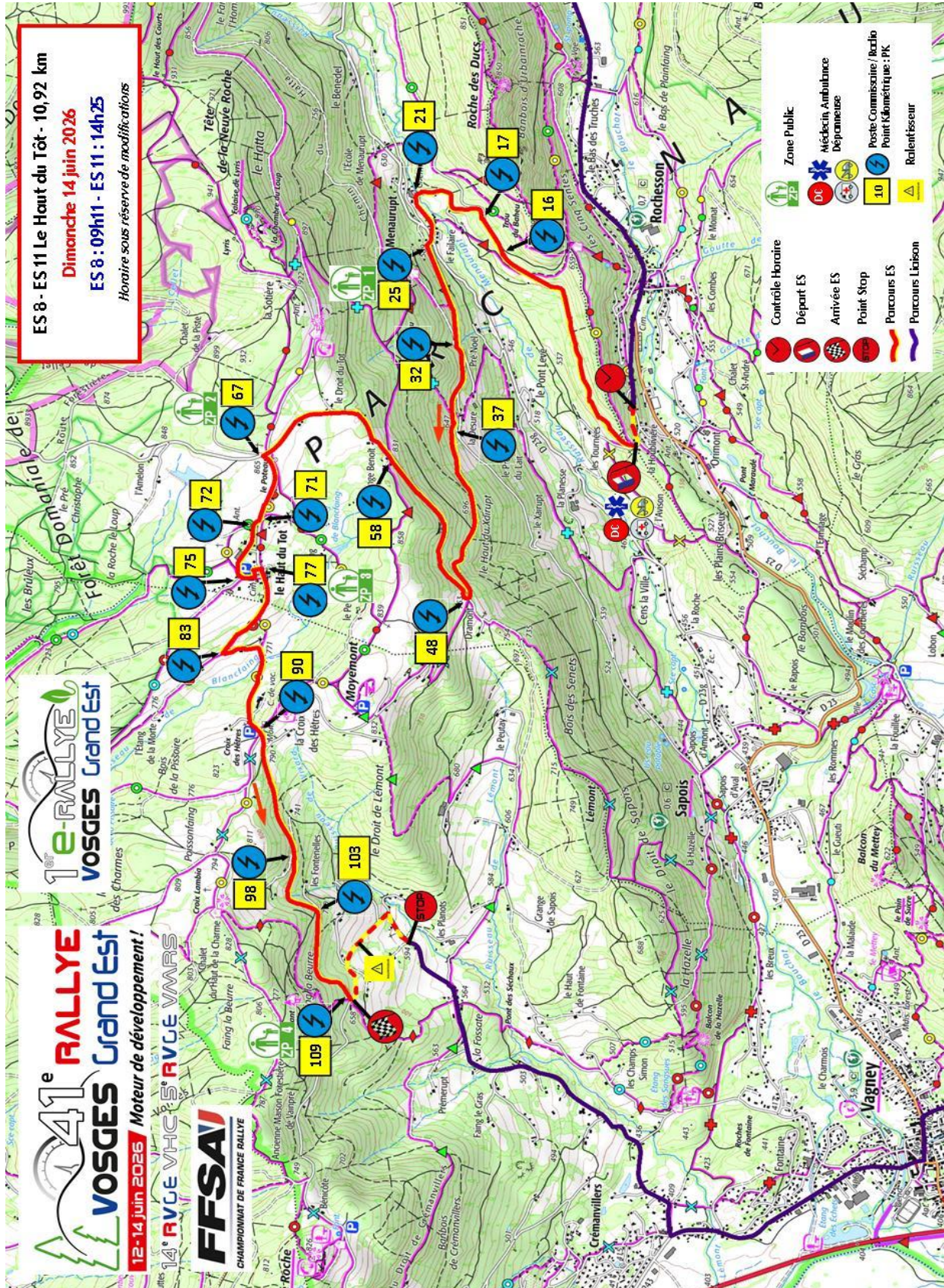

1er e-RVGE

CH	11	Avant ES11 / Before SS11 "Le Haut du Tôt"	SECTION 5	DISTANCE 19,55 km	PAGE 144
CH	12	Avant ES12 / Before SS12 "Les Trois Cols"			
EPREUVE SPECIALE / SPECIAL STAGE			VITESSE MOYENNE / AVERAGE SPEED	TEMPS IMPARTI / TARGET TIME	
ES/SS	11	"Le Haut du Tôt"	10,92 km	33,89 km/h	00h35min

DISTANCE		DIRECTIONS	INFORMATIONS	DISTANCE DEGRESSIVE
TOTALE	PARTIELLE			
0,00	0,00	<p>1</p>	<p>DEPART / START "LE HAUT DU TÔT" ES / SS 11</p> <p>Avant la route à gauche / Before the road on the left</p> <p>N 48°1'22.5" E 6°46'24.3"</p>	10,92 19,55
1,70	1,70	<p>2</p>	<p>CHEMIN du TREIX</p>	9,22 17,85
1,94	0,24	<p>3</p>	<p>CHEMIN du FAILLAIRE</p>	8,98 17,61
2,52	0,58	<p>4</p>	<p>C10</p> <p>5 Le Haut du Tôt</p>	8,40 17,03
3,19	0,67	<p>5</p>	<p>S.I. et SRP / N.I. and FMR</p>	7,73 16,36

Assistance interdite sur l'ensemble du parcours / Assistance forbidden on the whole course

1er e-RVGE

CH	11	Avant ES11 / Before SS11 "Le Haut du Tô't"	SECTION 5	DISTANCE 19,55 km	PAGE 145
CH	12	Avant ES12 / Before SS12 "Les Trois Cols"			
EPREUVE SPECIALE / SPECIAL STAGE			VITESSE MOYENNE / AVERAGE SPEED	TEMPS IMPARTI / TARGET TIME	
ES/SS	11	"Le Haut du Tô't"	10,92 km	33,89 km/h	00h35min

DISTANCE		DIRECTIONS	INFORMATIONS	DISTANCE DEGRESSIVE
TOTALE	PARTIELLE			
3,69	0,50	<p>6</p>		7,23 15,86
4,77	1,08	<p>7</p>	S.I. et SRP / N.I. and FMR	6,15 14,78
6,74	1,97	<p>8</p>		4,18 12,81
6,98	0,24	<p>9</p>	SRP / FMR	3,94 12,57
7,14	0,16	<p>10</p>	<p>Après la 2^e maison à gauche / After the second house on the left</p>	3,78 12,41

Assistance interdite sur l'ensemble du parcours / Assistance forbidden on the whole course

1er e-RVGE







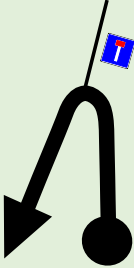

CH	11	Avant ES11 / Before SS11 "Le Haut du Tô't"	SECTION 5	DISTANCE 19,55 km	PAGE 146
CH	12	Avant ES12 / Before SS12 "Les Trois Cols"			
EPREUVE SPECIALE / SPECIAL STAGE			VITESSE MOYENNE / AVERAGE SPEED 33,89 km/h	TEMPS IMPARTI / TARGET TIME 00h35min	
ES/SS	11	"Le Haut du Tô't"	10,92 km		

DISTANCE		DIRECTIONS	INFORMATIONS	DISTANCE DEGRESSIVE
TOTALE	PARTIELLE			
7,21	0,07			3,71 12,34
7,54	0,33			3,38 12,01
7,62	0,08		S.I. / N.I.	3,30 11,93
7,67	0,05		S.I. / N.I.	3,25 11,88
7,78	0,11			3,14 11,77

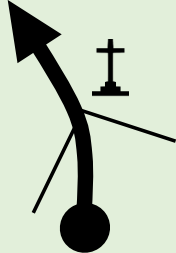
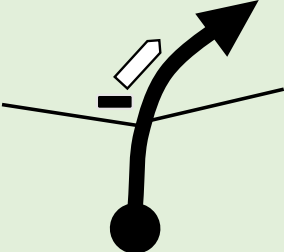
Assistance interdite sur l'ensemble du parcours / Assistance forbidden on the whole course

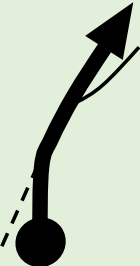
1er e-RVGE

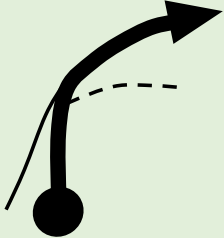
CH	11	Avant ES11 / Before SS11 "Le Haut du Tô't"	SECTION 5	DISTANCE 19,55 km	PAGE 147
CH	12	Avant ES12 / Before SS12 "Les Trois Cols"			
EPREUVE SPECIALE / SPECIAL STAGE			VITESSE MOYENNE / AVERAGE SPEED	TEMPS IMPARTI / TARGET TIME	
ES/SS	11	"Le Haut du Tô't"	10,92 km	33,89 km/h	00h35min

DISTANCE		DIRECTIONS	INFORMATIONS	DISTANCE DEGRESSIVE
TOTALE	PARTIELLE			
8,31	0,53	<div style="border: 1px solid black; padding: 2px; display: inline-block;">13</div>  <p style="text-align: right; margin-right: 20px;">PK 83 </p>	S.I. et SRP / N.I. and FMR	2,61 11,24
8,96	0,65		S.I. et SRP / N.I. and FMR	1,96 10,59
9,04	0,08	<div style="border: 1px solid black; padding: 2px; display: inline-block;">14</div>  <p style="text-align: right; margin-right: 20px;">PK 90 </p>	<div style="border: 1px solid black; padding: 5px; margin-bottom: 10px;"> La Croix des Hêtres <i>C^{ne} de VAGNEY</i> <i>Altitude 820m</i> </div> <div style="border: 1px solid black; padding: 5px; display: inline-block;"> VAGNEY 6  </div>	1,88 10,51
9,77	0,73	<div style="border: 1px solid black; padding: 2px; display: inline-block;">15</div>  <p style="text-align: right; margin-right: 20px;">PK 98 </p>	S.I. et SRP / N.I. and FMR	1,15 9,78
10,24	0,47	<div style="border: 1px solid black; padding: 2px; display: inline-block;">16</div>  <p style="text-align: right; margin-right: 20px;">PK 102 </p>	S.I. et SRP / N.I. and FMR	0,68 9,31

Assistance interdite sur l'ensemble du parcours / Assistance forbidden on the whole course

1er e-RVGE



CH	11	Avant ES11 / Before SS11 "Le Haut du Tô't"	SECTION 5	DISTANCE 19,55 km	PAGE 148
CH	12	Avant ES12 / Before SS12 "Les Trois Cols"			
EPREUVE SPECIALE / SPECIAL STAGE			VITESSE MOYENNE / AVERAGE SPEED	TEMPS IMPARTI / TARGET TIME	
ES/SS	11	"Le Haut du Tô't"	10,92 km	33,89 km/h	00h35min

DISTANCE		DIRECTIONS	INFORMATIONS	DISTANCE DEGRESSIVE
TOTALE	PARTIELLE			
10,92	0,68		<p>ARRIVEE / FINISH "LE HAUT DU TÔT" ES / SS 11</p> <p>Au croisement / At the crossroad</p> <p> N 48°2'13.5" E 6°43'46.2"</p>	0,00 8,63
11,23	0,31		<p>!!!</p> <p>RALENTISSEUR / DECELERATOR</p>	8,32
11,73	0,50		<p>POINT STOP "LE HAUT DU TÔT" ES / SS 11</p> <p>Au chemin à gauche / At the path on the left</p> <p> N 48°2'3.7" E 6°44'3.2"</p>	7,82
12,09	0,36		<p>Sortie Zone Casque / Helmet Area Exit</p> <p></p>	7,46
12,75	0,66		<p>Route de BLANCHE PIERRE</p>	6,80

Assistance interdite sur l'ensemble du parcours / Assistance forbidden on the whole course

1er e-RVGE

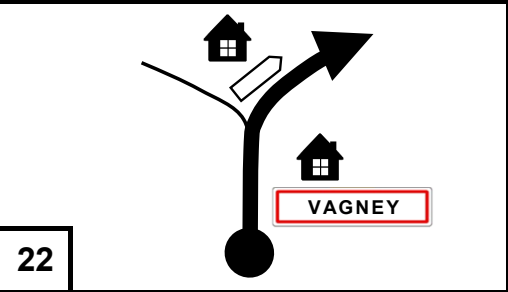
CH	11	Avant ES11 / Before SS11 "Le Haut du Tô't"	SECTION 5	DISTANCE 19,55 km	PAGE 149
CH	12	Avant ES12 / Before SS12 "Les Trois Cols"			
EPREUVE SPECIALE / SPECIAL STAGE			VITESSE MOYENNE / AVERAGE SPEED	TEMPS IMPARTI / TARGET TIME	
ES/SS			33,89 km/h	00h35min	

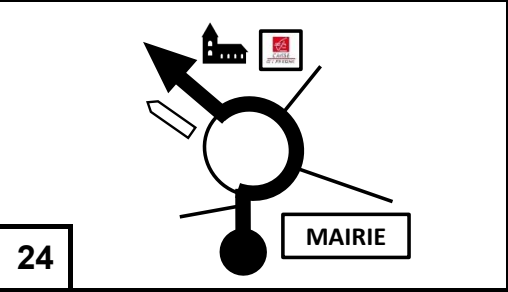
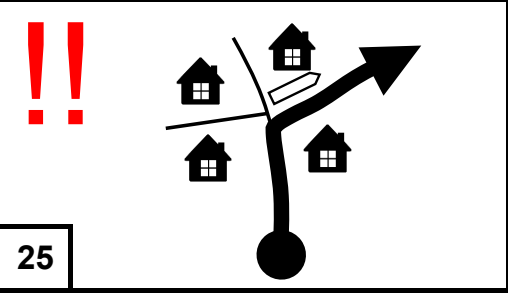
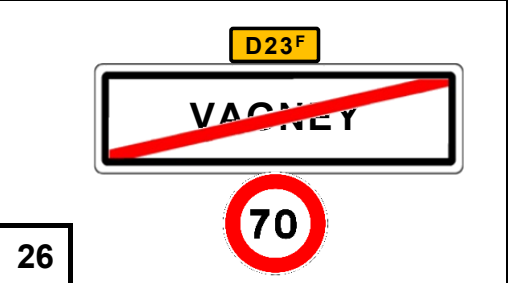
DISTANCE		DIRECTIONS	INFORMATIONS	DISTANCE DEGRESSIVE
TOTALE	PARTIELLE			
13,71	0,96		<p>VAGNEY-CENTRE</p> <p>AUTRES DIRECTIONS</p> <p>ADAC OPEL RALLY CUP → 149 Bis</p>	5,84
14,34	0,63		<p>D243</p> <p>2 VAGNEY 16 CORNIMONT</p>	5,21
15,91	1,57		<p>D23</p> <p>ROCHESSON 6</p> <p>GÉRARDMER 17</p> <p>SAPOIS 2</p> <p>GERBAMONT 3</p>	3,64
16,21	0,30		<p>D23^F</p> <p>GERBAMONT 3</p> <p>Saut du Bouchot 4</p>	3,34
16,77	0,56		SRP / FMR D23 ^F	2,78

Assistance interdite sur l'ensemble du parcours / Assistance forbidden on the whole course

1er e-RVGE

CH	11	Avant ES11 / Before SS11 "Le Haut du Tô't"	SECTION 5	DISTANCE 14,37 km	PAGE 149BIS
CH	11A	Remote Charging IN			
EPREUVE SPECIALE / SPECIAL STAGE			VITESSE MOYENNE / AVERAGE SPEED	TEMPS IMPARTI / TARGET TIME	
ES/SS			-	00h10min	

DISTANCE		DIRECTIONS	INFORMATIONS	DISTANCE DEGRESSIVE
TOTALE	PARTIELLE			
14,34	0,00			0,05
14,39	0,05		<p>CH 11A Remote Charging IN</p>	0,00











Remote Charging Truck location

Parking Transports STEFF

11, route de Remiremont - 88120 VAGNEY



1er e-RVGE					
CH	11A	Remote Charging IN	SECTION	DISTANCE	PAGE
CH	11B	Remote Charging OUT	5	0,00 km	
EPREUVE SPECIALE / SPECIAL STAGE			VITESSE MOYENNE / AVERAGE SPEED	TEMPS IMPARTI / TARGET TIME	151BIS
ES/SS			-	00h15min	
DISTANCE		DIRECTIONS	INFORMATIONS		DISTANCE DEGRESSIVE
TOTALE	PARTIELLE				
0,00	0,00	 REMOTE CHARGING 	 <u>CH 11A</u> Remote Charging IN  N 48°1'16.6" E 6°42'36.6"	0,00	
0,00	0,00	 REMOTE CHARGING  1	 <u>CH 11B</u> Remote Charging OUT  N 48°1'16.6" E 6°42'36.6"	0,00	

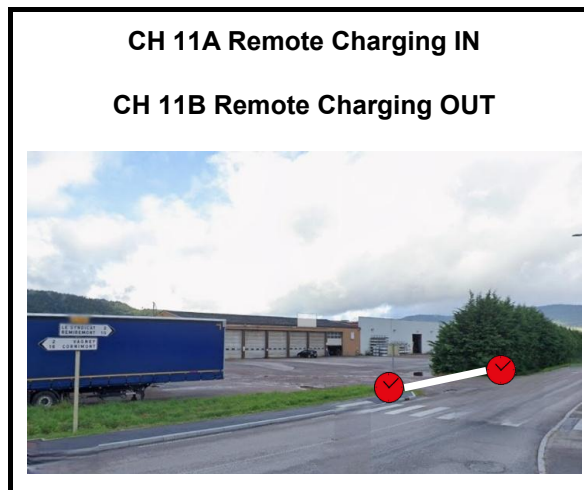

SECTION 5 CH 11A

SECTION 5 CH 11B

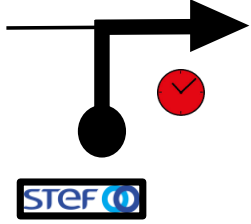

1er e-RVGE

CH	11B	Remote Charging OUT	SECTION 5	DISTANCE 5,28 km	PAGE 152BIS
CH	12	Avant ES12 / Before SS12 "Les Trois Cols"			
EPREUVE SPECIALE / SPECIAL STAGE			VITESSE MOYENNE / AVERAGE SPEED	TEMPS IMPARTI / TARGET TIME	
ES/SS			-	00h25min	

DISTANCE		DIRECTIONS	INFORMATIONS	DISTANCE DEGRESSIVE
TOTALE	PARTIELLE			
0,00	0,00		 CH 11B Remote Charging OUT  N 48°1'16.6" E 6°42'36.6"	5,28

puis reprendre / then
resume

Case 24 page 149

à / at 1,58 km

1er e-RVGE

CH	11	Avant ES11 / Before SS11 "Le Haut du Tô't"	SECTION	DISTANCE	PAGE 150
CH	12	Avant ES12 / Before SS12 "Les Trois Cols"	5	19,55 km	
EPREUVE SPECIALE / SPECIAL STAGE			VITESSE MOYENNE / AVERAGE SPEED	TEMPS IMPARTI / TARGET TIME	
ES/SS			33,89 km/h	00h35min	

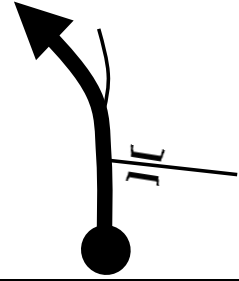
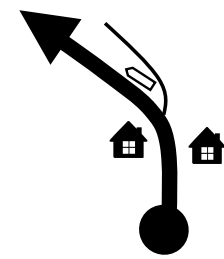
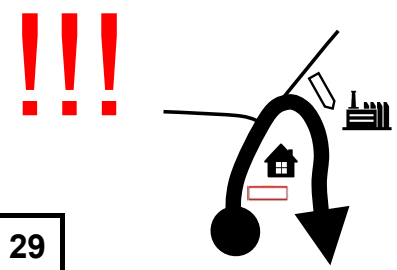
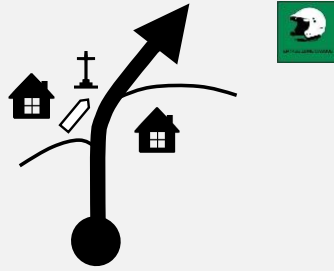
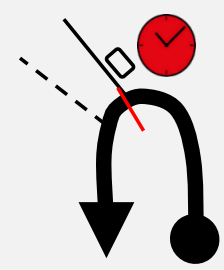
DISTANCE		DIRECTIONS	INFORMATIONS	DISTANCE DEGRESSIVE
TOTALE	PARTIELLE			
17,89	1,12	<div style="border: 1px solid black; padding: 2px; display: inline-block;">27</div> 	SRP / FMR D23 ^F	1,66
18,55	0,66	<div style="border: 1px solid black; padding: 2px; display: inline-block;">28</div> 	<div style="border: 1px solid black; padding: 5px; display: inline-block;"> D23^F 1 GERBAMONT <i>Saut du Bouchot</i> </div>	1,00
19,02	0,47	<div style="border: 1px solid black; padding: 2px; display: inline-block;">29</div> 	<div style="border: 1px solid black; padding: 5px; display: inline-block;"> D23^F <div style="border: 2px solid red; padding: 2px; display: inline-block; margin: 5px;">GERBAMONT</div> <div style="border: 1px solid black; padding: 2px; display: inline-block; margin: 5px;">C9</div> <div style="border: 1px solid black; padding: 2px; display: inline-block; margin: 5px;">GERBAMONT -Mairie</div> </div>	0,53
19,47	0,45	<div style="border: 1px solid black; padding: 2px; display: inline-block;">30</div> 	<div style="border: 1px solid black; padding: 5px; display: inline-block;"> Entrée Zone Casque / Helmet Area Entry <div style="border: 1px solid black; padding: 2px; display: inline-block; margin: 5px;">Les Plateaux</div> <div style="border: 1px solid black; padding: 2px; display: inline-block; margin: 5px;">La Cantonne</div> <div style="border: 1px solid black; padding: 2px; display: inline-block; margin: 5px;">ferme</div> <div style="border: 1px solid black; padding: 2px; display: inline-block; margin: 5px;">Les Plateaux</div> </div>	0,08
19,55	0,08	<div style="border: 1px solid black; padding: 2px; display: inline-block;">30</div> 	<div style="border: 1px solid black; padding: 5px; display: inline-block;"> CH 12 A la route à droite / At the road on the right "IMPASSE DE L'ENVERS" <div style="border: 1px solid black; padding: 5px; display: inline-block; margin: 5px;"> N 48°0'9.9" E 6°45'1.9" </div> </div>	0,00

0,06 km avant Départ ES12 "Les Trois Cols" / 0,06 km before the start of SS12 "Les Trois Cols"

1er e-RVGE

EPREUVE SPECIALE / SPECIAL STAGE

SECTION

5

PAGE

151

ES/SS

12

"Les Trois Cols"

14,24 km

1ère / 1st
A290
17h42

C.H. 12

N 48°0'9.9"
E 6°45'1.9"



DEPART / START

N 48°0'10.9"
E 6°45'4.6"

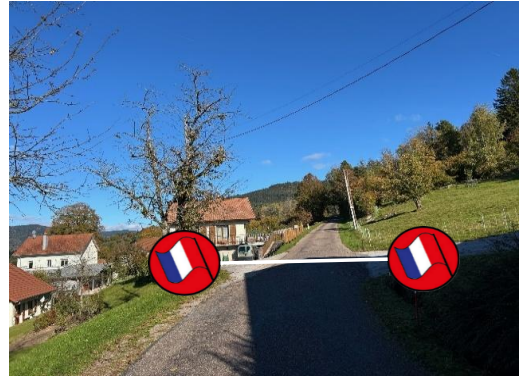

ARRIVEE / FINISH



ADAC OPEL
RALLY CUP

N 47°58'59.0"
E 6°47'55.5"

TROPHÉE
A290
RALLYE

N 47°59'9.4"
E 6°47'59.7"



POINT STOP

N 47°59'16.9"
E 6°47'51.3"



Fermeture de la route à :

1ère/1st car :

de 08h00 à 20h00

17h42

152

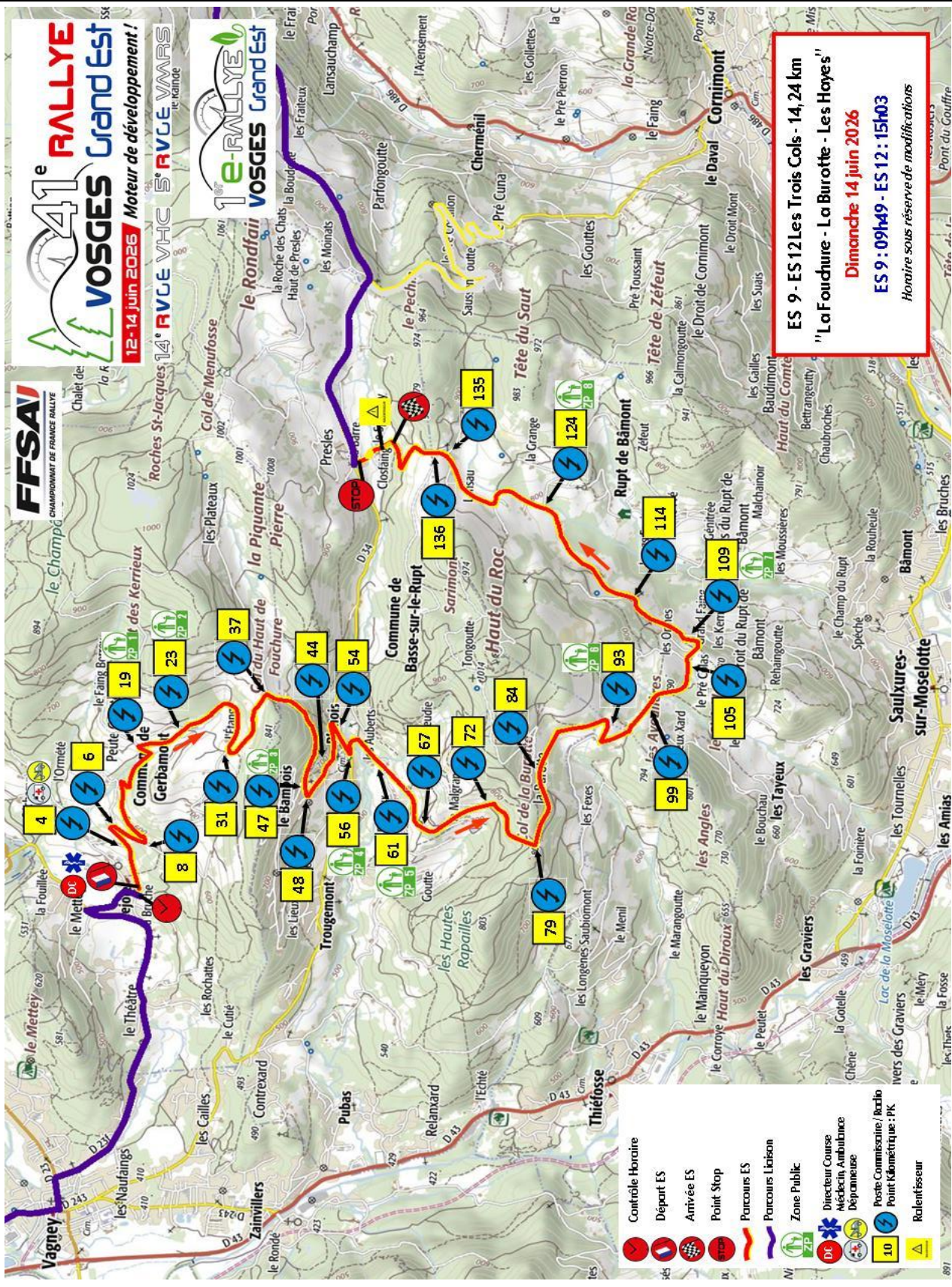

1er e-RVGE











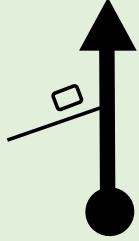



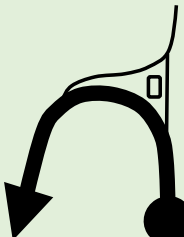

CH	12	Avant ES12 / Before SS12 "Les Trois Cols"	SECTION	DISTANCE	PAGE
CH	12A	Repositionnement IN	5	34,63 km	
EPREUVE SPECIALE / SPECIAL STAGE			VITESSE MOYENNE / AVERAGE SPEED	TEMPS IMPARTI / TARGET TIME	153
ES/SS	12	"Les Trois Cols"	14,24 km	47,03 km/h	

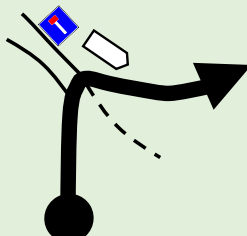
DISTANCE		DIRECTIONS	INFORMATIONS	DISTANCE DEGRESSIVE
TOTALE	PARTIELLE			
0,00	0,00	<div style="display: flex; justify-content: center; align-items: center;"> </div> <div style="display: flex; justify-content: space-between; align-items: center; margin-top: 5px;"> 1 DES </div>	<div style="display: flex; justify-content: space-between; align-items: center;"> <div style="font-size: 0.8em;"> <small>COMMUNICATEUR</small> <small>DÉBUT DE ZONE</small> <small>À</small> <small>VITESSE</small> <small>LIMITÉE</small> <small>CONTRÔLES</small> <small>FRAN</small> </div> <div style="text-align: center;"> DEPART / START "LES TROIS COLS" ES / SS 12 </div> <div style="font-size: 0.7em; margin-top: 5px;"> <small>A la place devant les hangars à droite / In</small> <small>front of the hangars on the right</small> </div> <div style="border: 1px solid black; padding: 5px; margin-top: 5px; display: flex; align-items: center;"> <div style="margin-left: 5px;"> <small>N 48°0'10.9"</small> <small>E 6°45'4.6"</small> </div> </div> </div> <div style="text-align: center; margin-top: 10px;"> </div>	<div style="color: red; font-weight: bold;">14,24</div> <div style="color: black;">34,63</div>
0,38	0,38	<div style="display: flex; justify-content: center; align-items: center;"> </div> <div style="display: flex; justify-content: space-between; align-items: center; margin-top: 5px;"> 2 PK 4 </div>	<div style="text-align: center; margin-top: 10px;"> </div> <div style="text-align: center; margin-top: 10px;"> </div>	<div style="color: red; font-weight: bold;">13,86</div> <div style="color: black;">34,25</div>
0,56	0,18	<div style="display: flex; justify-content: center; align-items: center;"> </div> <div style="display: flex; justify-content: space-between; align-items: center; margin-top: 5px;"> 3 PK 6 </div>	<div style="text-align: center; margin-top: 10px;"> </div> <div style="text-align: center; margin-top: 10px;"> </div>	<div style="color: red; font-weight: bold;">13,68</div> <div style="color: black;">34,07</div>
0,84	0,28	<div style="display: flex; justify-content: center; align-items: center;"> </div> <div style="display: flex; justify-content: space-between; align-items: center; margin-top: 5px;"> 4 PK 8 </div>	<div style="text-align: center; margin-top: 10px;"> </div> <div style="text-align: center; margin-top: 10px;"> </div>	<div style="color: red; font-weight: bold;">13,40</div> <div style="color: black;">33,79</div>
1,87	1,03	<div style="display: flex; justify-content: center; align-items: center;"> </div> <div style="display: flex; justify-content: space-between; align-items: center; margin-top: 5px;"> 5 PK 19 </div>	<div style="text-align: center; margin-top: 10px;"> </div> <div style="text-align: center; margin-top: 10px;"> </div>	<div style="color: red; font-weight: bold;">12,37</div> <div style="color: black;">32,76</div>

Assistance interdite sur l'ensemble du parcours / Assistance forbidden on the whole course

1er e-RVGE









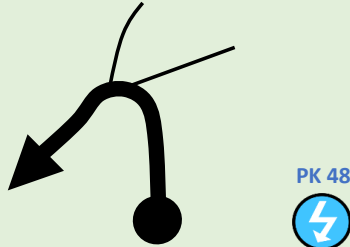

CH	12	Avant ES12 / Before SS12 "Les Trois Cols"	SECTION 5	DISTANCE 34,63 km	PAGE 154
CH	12A	Repositionnement IN			
EPREUVE SPECIALE / SPECIAL STAGE			VITESSE MOYENNE / AVERAGE SPEED 47,03 km/h	TEMPS IMPARTI / TARGET TIME 00h45min	
ES/SS	12	"Les Trois Cols"	14,24 km		

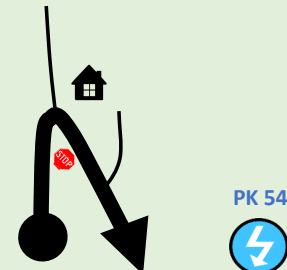
DISTANCE		DIRECTIONS	INFORMATIONS	DISTANCE DEGRESSIVE
TOTALE	PARTIELLE			
2,26	0,39	 PK 23  6	 	11,98 32,37
3,08	0,82	 PK 31  7	 	11,16 31,55
3,71	0,63	 PK 37  8	 	10,53 30,92
3,89	0,18	 9	 S.I. et SRP / N.I. and FMR	10,35 30,74
4,68	0,79	 PK 47  10	 S.I. et SRP / N.I. and FMR	9,56 29,95

Assistance interdite sur l'ensemble du parcours / Assistance forbidden on the whole course

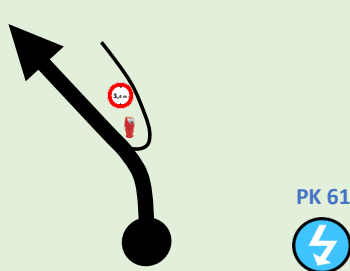
1er e-RVGE

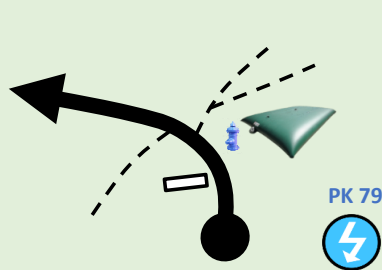









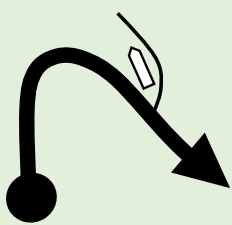

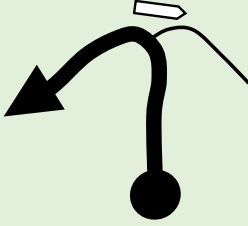





CH	12	Avant ES12 / Before SS12 "Les Trois Cols"	SECTION	DISTANCE	PAGE
CH	12A	Repositionnement IN	5	34,63 km	
EPREUVE SPECIALE / SPECIAL STAGE			VITESSE MOYENNE / AVERAGE SPEED	TEMPS IMPARTI / TARGET TIME	155
ES/SS	12	"Les Trois Cols"	14,24 km	47,03 km/h	

DISTANCE		DIRECTIONS	INFORMATIONS	DISTANCE DEGRESSIVE
TOTALE	PARTIELLE			9,48
4,76	0,08		 S.I. et SRP / N.I. and FMR	29,87
5,39	0,63		 S.I. et SRP / N.I. and FMR	29,24
5,63	0,24		 <div style="border: 1px solid black; padding: 2px; margin: 5px; text-align: center;">La Burotte</div> <div style="border: 1px solid black; padding: 2px; margin: 5px; text-align: center;">La Burotte</div> <div style="border: 1px solid black; padding: 2px; margin: 5px; text-align: center;">étang du Moulin</div>	29,00
6,11	0,48		 S.I. et SRP / N.I. and FMR	28,52
7,88	1,77		 <div style="border: 1px solid black; padding: 2px; margin: 5px; text-align: center;">La Burotte</div>	26,75

Assistance interdite sur l'ensemble du parcours / Assistance forbidden on the whole course

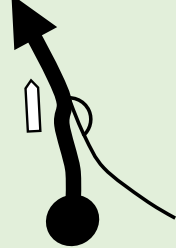
1er e-RVGE

CH	12	Avant ES12 / Before SS12 "Les Trois Cols"	SECTION	DISTANCE	PAGE
CH	12A	Repositionnement IN	5	34,63 km	
EPREUVE SPECIALE / SPECIAL STAGE			VITESSE MOYENNE / AVERAGE SPEED	TEMPS IMPARTI / TARGET TIME	156
ES/SS	12	"Les Trois Cols"	14,24 km	47,03 km/h	

DISTANCE		DIRECTIONS	INFORMATIONS	DISTANCE DEGRESSIVE
TOTALE	PARTIELLE			TOTAL
9,30	1,42	 <div style="text-align: right; font-size: 0.8em;">  </div>	<div style="text-align: right; font-size: 2em; color: red; border: 1px solid red; border-radius: 50%; padding: 5px;">50</div> 	<div style="color: red; font-weight: bold;">4,94</div> 25,33
9,42	0,12	 <div style="text-align: right; font-size: 0.8em;">  </div>	<div style="text-align: right; font-size: 2em; color: red; border: 1px solid red; border-radius: 50%; padding: 5px;">50</div>  <div style="font-size: 0.7em;">  </div>	<div style="color: red; font-weight: bold;">4,82</div> 25,21
9,87	0,45	 <div style="text-align: right; font-size: 0.8em;">  </div>	<div style="text-align: right; font-size: 2em; color: red; border: 1px solid red; border-radius: 50%; padding: 5px;">30</div>    <div style="font-size: 0.7em;">  </div>	<div style="color: red; font-weight: bold;">4,37</div> 24,76
10,50	0,63	 <div style="text-align: right; font-size: 0.8em;">  </div>	<div style="text-align: right; font-size: 2em; color: red; border: 1px solid red; border-radius: 50%; padding: 5px;">30</div> S.I. et SRP / N.I. and FMR	<div style="color: red; font-weight: bold;">3,74</div> 24,13
10,88	0,38	 <div style="text-align: right; font-size: 0.8em;">  </div>	<div style="text-align: right; font-size: 2em; color: red; border: 1px solid red; border-radius: 50%; padding: 5px;">30</div>   <div style="font-size: 0.7em;">  </div>	<div style="color: red; font-weight: bold;">3,36</div> 23,75

Assistance interdite sur l'ensemble du parcours / Assistance forbidden on the whole course

1er e-RVGE





CH	12	Avant ES12 / Before SS12 "Les Trois Cols"	SECTION 5	DISTANCE 34,63 km	PAGE 157
CH	12A	Repositionnement IN			
EPREUVE SPECIALE / SPECIAL STAGE			VITESSE MOYENNE / AVERAGE SPEED 47,03 km/h	TEMPS IMPARTI / TARGET TIME 00h45min	
ES/SS	12	"Les Trois Cols"	14,24 km		

DISTANCE		DIRECTIONS	INFORMATIONS	DISTANCE DEGRESSIVE
TOTALE	PARTIELLE			
12,38	1,50		 	1,86 22,25
13,50	1,12		 S.I. et SRP / N.I. and FMR	0,74 21,13
13,60	0,10		 N 47°58'59.0" E 6°47'55.5"	0,64 21,03
14,24	0,64		 N 47°59'16.9" E 6°47'51.3"	0,00 20,39
14,36	0,12		 	20,27

Assistance interdite sur l'ensemble du parcours / Assistance forbidden on the whole course

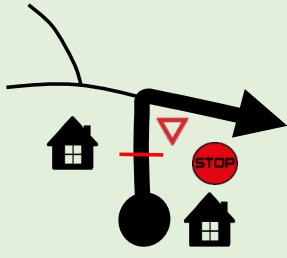
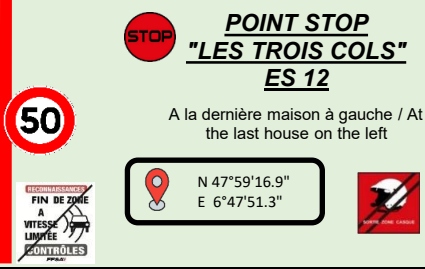
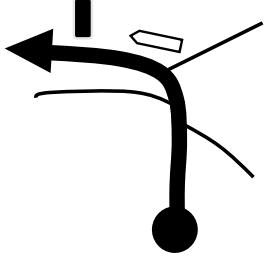
1er e-RVGE







CH	12	Avant ES12 / Before SS12 "Les Trois Cols"	SECTION 5	DISTANCE 34,63 km	PAGE 158
CH	12A	Repositionnement IN			
EPREUVE SPECIALE / SPECIAL STAGE			VITESSE MOYENNE / AVERAGE SPEED	TEMPS IMPARTI / TARGET TIME	
ES/SS	12	"Les Trois Cols"	14,24 km	47,03 km/h	00h45min

DISTANCE		DIRECTIONS	INFORMATIONS	DISTANCE DEGRESSIVE
TOTALE	PARTIELLE			
14,60	0,24	 25	 POINT STOP "LES TROIS COLS" ES 12 A la dernière maison à gauche / At the last house on the left N 47°59'16.9" E 6°47'51.3"	20,03
16,22	1,62	 26		18,41
18,43	2,21	 27	SRP / FMR D34	16,20
19,98	1,55	 28	SRP / FMR D34	14,65
21,01	1,03	 29	SRP / FMR D34	13,62

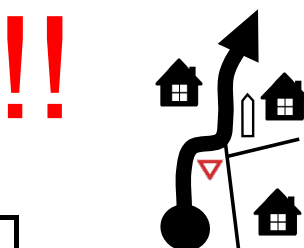
Assistance interdite sur l'ensemble du parcours / Assistance forbidden on the whole course

1er e-RVGE

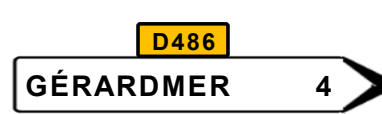
CH	12	Avant ES12 / Before SS12 "Les Trois Cols"	SECTION 5	DISTANCE 34,63 km	PAGE 159
CH	12A	Repositionnement IN			
EPREUVE SPECIALE / SPECIAL STAGE			VITESSE MOYENNE / AVERAGE SPEED	TEMPS IMPARTI / TARGET TIME	
ES/SS			47,03 km/h	00h45min	

DISTANCE		DIRECTIONS	INFORMATIONS	DISTANCE DEGRESSIVE
TOTALE	PARTIELLE			
21,38	0,37	 30		13,25
21,83	0,45	 31	SRP / FMR D486	12,80
26,13	4,30	 32	SRP / FMR D486	8,50
29,44	3,31	 33		5,19
32,37	2,93	 34	SRP / FMR D486	2,26

Assistance interdite sur l'ensemble du parcours / Assistance forbidden on the whole course

1er e-RVGE

CH	12	Avant ES12 / Before SS12 "Les Trois Cols"	SECTION 5	DISTANCE 34,63 km	PAGE 160
CH	12A	Repositionnement IN			
EPREUVE SPECIALE / SPECIAL STAGE			VITESSE MOYENNE / AVERAGE SPEED 47,03 km/h	TEMPS IMPARTI / TARGET TIME 00h45min	
ES/SS					

DISTANCE		DIRECTIONS	INFORMATIONS	DISTANCE DEGRESSIVE
TOTALE	PARTIELLE			
33,16	0,79	 35		1,47
33,40	0,24	 36		1,23
33,61	0,21	 37		1,02
33,84	0,23	 38		0,79
34,07	0,23	 39	S.I. / N.I.	0,56

Assistance interdite sur l'ensemble du parcours / Assistance forbidden on the whole course

1er e-RVGE

CH	12	Avant ES12 / Before SS12 "Les Trois Cols"	SECTION 5	DISTANCE 34,63 km	PAGE 161
CH	12A	Repositionnement IN			
EPREUVE SPECIALE / SPECIAL STAGE			VITESSE MOYENNE / AVERAGE SPEED	TEMPS IMPARTI / TARGET TIME	
ES/SS			47,03 km/h	00h45min	

DISTANCE		DIRECTIONS	INFORMATIONS	DISTANCE DEGRESSIVE
TOTALE	PARTIELLE			
34,24	0,17			0,39
34,48	0,24			0,15
34,62	0,14		S.I. / N.I.	0,01
34,63	0,01		CH 12A Entrée Parc de Repositionnement / Entrance repositionning park Pointage en avance autorisé / Early check-in allowed	0,00

1er e-RVGE

CH	12	Avant ES12 / Before SS12 "Les Trois Cols"	SECTION	DISTANCE	PAGE
CH	12A	Repositionnement IN	5	34,63 km	
EPREUVE SPECIALE / SPECIAL STAGE			VITESSE MOYENNE / AVERAGE SPEED	TEMPS IMPARTI / TARGET TIME	162
ES/SS			47,03 km/h	00h45min	

SECTION 5 | CH 12A

00:15 minimum

C.H.12A Repositionnement IN

 N 48°04'17.2" E 6°52'50.9"



1er e-RVGE

CH	12A	Repositionnement IN	SECTION 5	DISTANCE 1,32 km	PAGE 163
CH		Remise des Prix			
EPREUVE SPECIALE			VITESSE MOYENNE -	TEMPS IMPARTI -	
ES N°					

DISTANCE		DIRECTIONS	INFORMATIONS	DISTANCE DEGRESSIVE
TOTALE	PARTIELLE			
0,00	0,00		Sortie Parc de Repositionnement / Exit repositionning park et S.I. / and N.I.	1,32
0,25	0,25		S.I. / N.I.	1,07
0,49	0,24		S.I. / N.I.	0,83
0,71	0,22		<div style="border: 1px solid black; padding: 2px; margin-bottom: 2px;">Centre Médico-Social</div> <div style="border: 1px solid black; padding: 2px; margin-bottom: 2px;">Finances Publiques et Trésorerie</div> <div style="border: 1px solid black; padding: 2px;">P Casino - Pl du Tilleul</div>	0,61
0,89	0,18		<div style="border: 1px solid black; padding: 2px; margin-bottom: 2px;">Office de Tourisme</div> <div style="border: 1px solid black; padding: 2px; margin-bottom: 2px;">COTEAU DES XETTES</div> <div style="border: 1px solid black; padding: 2px;">P Pl des Déportés</div>	0,43

1er e-RVGE

CH	12A	Repositionnement IN	SECTION 5	DISTANCE 1,32 km	PAGE 164
CH		Remise des Prix			
EPREUVE SPECIALE			VITESSE MOYENNE -	TEMPS IMPARTI -	
ES N°					

DISTANCE		DIRECTIONS	INFORMATIONS	DISTANCE DEGRESSIVE
TOTALE	PARTIELLE			
1,00	0,11			0,32
1,13	0,13		S.I. / N.I.	0,19
1,19	0,06		S.I. / N.I.	0,13
1,27	0,08		S.I. / N.I.	0,05
1,32	0,05		Remise des Prix / Final Podium	0,00

6

Déviations

Index des itinéraires de déviation

CORCIEUX

Depuis le départ de l'ES e1/3/6 "Corcieux" vers le CH e1A/3A/6A:
pages D1-D2-D3

Depuis le PK 42 de l'ES e1/3/6 "Corcieux" vers le CH e1A/3A/6A:
pages D4

Depuis le PK 128 de l'ES e1/3/6 "Corcieux" vers le CH e1A/3A/6A:
pages D5

VOLOGNE

Depuis le départ de l'ES 7 "Vologne" vers le CH 7A :
pages D6-D7

Depuis le PK 96 de l'ES 7 "Vologne" vers le CH 7A :
pages D8-D9-D10-D11

LE HAUT DU TÔT

Depuis le départ de l'ES 11 "Le Haut du Tô" vers le départ de l'ES 12
"Les Trois Cols" :
pages D12-D13

Depuis le PK 25 de l'ES 11 "Le Haut du Tô" vers le départ de l'ES 12
"Les Trois Cols" :
pages D14-D15

LES TROIS COLS

Depuis le départ de l'ES 9/12 "Les Trois Cols" vers le CH9A / CH12A :
pages D16-D17

Depuis le PK 54 de l'ES 9/12 "Les Trois Cols" vers le CH9A / CH12A :
pages D18

1er e-RVGE

Déviation 1 ES / SS e1 Corcieux

PAGE

D1



1er e-RVGE

Déviation 1 ES / SS e1 Corcieux				PAGE D2
SECTION 1	ES/SS e1	à CH e1A	DISTANCE TOTALE 25,41 km	
Déviation 1 ES 3 / SS 3 Corcieux				
SECTION 2	ES/SS 3	à CH 3	DISTANCE TOTALE 25,41 km	
Déviation 1 ES 6 / SS 6 Corcieux				
SECTION 3	ES/SS 6	à CH e6	DISTANCE TOTALE 25,41 km	

DISTANCE		DIRECTIONS	INFORMATIONS	DISTANCE DEGRESSIVE
TOTALE	PARTIELLE			
5,01	1,50			20,40
5,13	0,12		SRP / FMR D81	20,28
		6		
5,40	0,27			20,01
		7		
5,87	0,47		SRP / FMR D81	19,54
		8		
8,04	2,17		SRP / FMR D81	17,37
		9		

1er e-RVGE

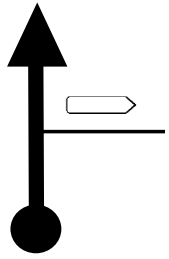
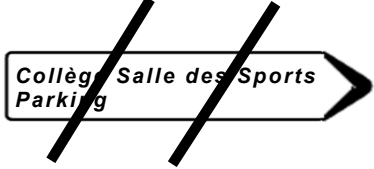
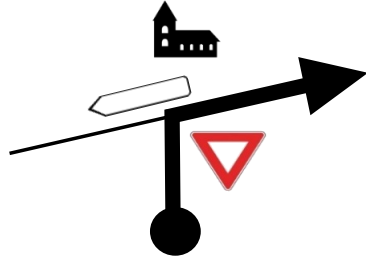
Déviation 1 ES / SS e1 Corcieux				PAGE D3
SECTION 1	ES/SS e1	à CH e1A	DISTANCE TOTALE 25,41 km	
Déviation 1 ES 3 / SS 3 Corcieux				
SECTION 2	ES/SS 3	à CH 3	DISTANCE TOTALE 25,41 km	
Déviation 1 ES 6 / SS 6 Corcieux				
SECTION 3	ES/SS 6	à CH e6	DISTANCE TOTALE 25,41 km	

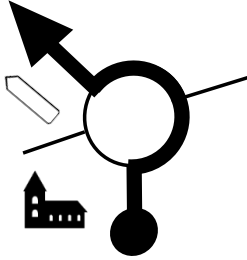
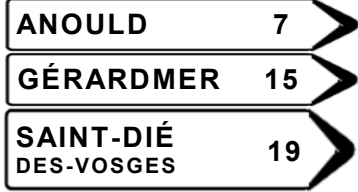
DISTANCE		DIRECTIONS	INFORMATIONS	DISTANCE DEGRESSIVE
TOTALE	PARTIELLE			
8,67	0,63	 <div style="border: 1px solid black; padding: 2px; display: inline-block; margin-top: 5px;">10</div>		16,74
8,83	0,16			16,58
8,89	0,06	 <div style="border: 1px solid black; padding: 2px; display: inline-block; margin-top: 5px;">11</div>	<div style="border: 1px solid black; padding: 2px; display: inline-block; margin-bottom: 5px;">D60</div> 	16,52

puis reprendre / then resume :

Case 39 page 24
Case 39 page 51
Case 39 page 78

à / at 0,37 km





1er e-RVGE

Déviation 2 ES / SS e1 Corcieux

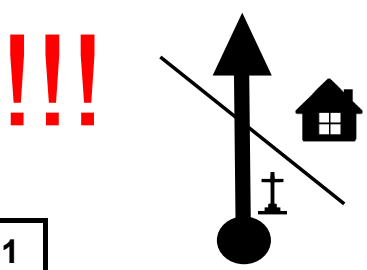

PAGE

D4

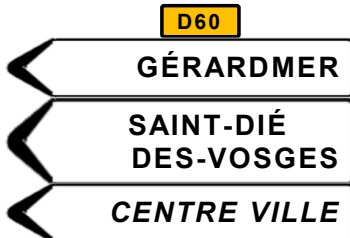
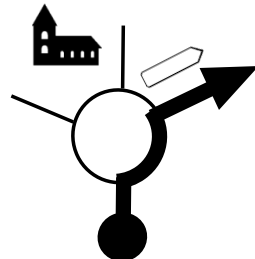
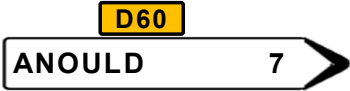
SECTION	1	PK42 ES/SSe1	à	CH e1A	DISTANCE TOTALE	26,13 km
Déviation 2 ES / SS 3 Corcieux						
SECTION	2	PK42 ES/SS 3	à	CH 3A	DISTANCE TOTALE	26,13 km
Déviation 2 ES / SS 6 Corcieux						
SECTION	3	PK42 ES/SS 6	à	CH 6A	DISTANCE TOTALE	26,13 km

DISTANCE		DIRECTIONS	INFORMATIONS	DISTANCE DEGRESSIVE
TOTALE	PARTIELLE			
4,22	0,00	 <p>1</p>	<p>Case 9B page 17 Case 9B page 44 Case 9B page 71</p> <p>Modifiée / Modified</p> <p>!! sortie itinéraire ES / Exit SS itinerary !!</p>	21,91
5,52	1,30	 <p>2</p>	SRP / FMR D60	20,61
9,12	3,60	 <p>3</p>	SRP / FMR D60	17,01
9,39	0,27	 <p>4</p>		16,74
9,61	0,22	 <p>5</p>	 <p>puis reprendre / the resume</p> <p>Case 39 page 24 Case 39 page 51 Case 39 page 78</p> <p>à / at 0,37 km</p>	16,52

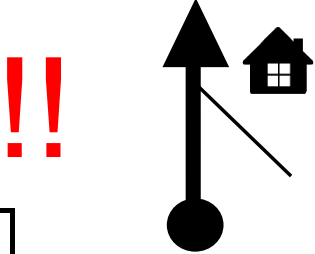
1er e-RVGE					
Déviation 3 ES / SS e1 Corcieux				PAGE D5	
SECTION	1	PK128 ES/SSe1	à CH e1A		DISTANCE TOTALE 26,13 km
Déviation 3 ES / SS 3 Corcieux					
SECTION	2	PK128 ES/SS 3	à CH 3A	DISTANCE TOTALE 26,13 km	
Déviation 3 ES / SS 6 Corcieux					
SECTION	3	PK128 ES/SS 6	à CH 6A	DISTANCE TOTALE 26,13 km	

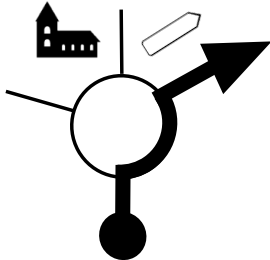
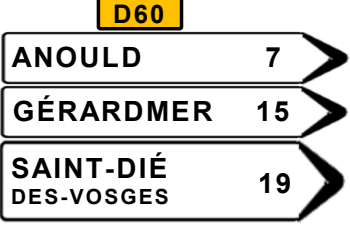

DISTANCE		DIRECTIONS	INFORMATIONS	DISTANCE DEGRESSIVE
TOTALE	PARTIELLE			
12,84	0,00	 1	<p>Case 22B page 20 Case 22B page 47 Case 22B page 74</p> <p>Modifiée / Modified</p> <p>!! sortie itinéraire ES / Exit SS itinerary !!</p>	19,07
14,96	2,12	 2	SRP / FMR D31	16,95
15,39	0,43	 3		16,52

puis reprendre / then resume :

Case 39 page 24
Case 39 page 51
Case 39 page 78



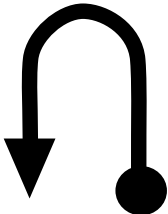

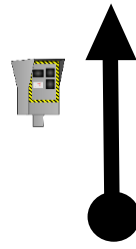
à / at 0,37 km

1er e-RVGE			
Déviation 1 ES / SS 7 Vologne			PAGE D6
SECTION	4	DES 7 à CH 7A	

DISTANCE		DIRECTIONS	INFORMATIONS	DISTANCE DEGRESSIVE
TOTALE	PARTIELLE			
0,00	0,00	 <div style="border: 1px solid black; padding: 2px; display: inline-block;">1</div>	Demi-tour sur ligne de départ / Half-lap on the starting line : DES 7	18,05
0,71	0,71	<div style="text-align: center;"> <div style="border: 1px solid black; padding: 2px; display: inline-block; background-color: yellow;">D50^E</div> <div style="border: 2px solid red; padding: 5px; display: inline-block;"> AUMONTZEY C^{te} de GRANGES-AUMONTZEY </div> </div> <div style="border: 1px solid black; padding: 2px; display: inline-block; margin-top: 5px;">2</div>	SRP / FMR D50 ^E	17,34
1,37	0,66	 <div style="border: 1px solid black; padding: 2px; display: inline-block; margin-top: 5px;">3</div>	<div style="text-align: center;"> <div style="border: 1px solid black; padding: 2px; display: inline-block; background-color: yellow;">D423</div> <div style="border: 1px solid black; padding: 5px; display: inline-block;"> GRANGES SUR VOLOGNE 3 GERARDMER 16 </div> </div>	16,68
1,51	0,14	 <div style="border: 1px solid black; padding: 2px; display: inline-block; margin-top: 5px;">3</div>	!! ATTENTION RADAR / WARNING RADAR !!	16,54
1,74	0,23	<div style="text-align: center;"> <div style="border: 1px solid black; padding: 2px; display: inline-block; background-color: yellow;">D423</div> <div style="border: 1px solid black; padding: 5px; display: inline-block; text-decoration: line-through;">AUMONTZEY</div> <div style="border: 2px solid red; border-radius: 50%; padding: 10px; display: inline-block; margin-top: 10px;">70</div> </div> <div style="border: 1px solid black; padding: 2px; display: inline-block; margin-top: 5px;">4</div>	SRP / FMR D423	16,31

Assistance interdite sur l'ensemble du parcours

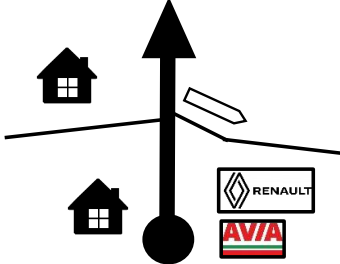
1er e-RVGE					
Déviation 1 ES / SS 7 Vologne				PAGE D7	
SECTION	4	DES 7	à CH 7A		DISTANCE TOTALE 18,05 km

DISTANCE		DIRECTIONS	INFORMATIONS	DISTANCE DEGRESSIVE
TOTALE	PARTIELLE			
3,00	1,26	 	SRP / FMR D423	15,05
3,15	0,15	 5		14,90
		<p>puis reprendre / then resume</p> <p>Case 43 page 109</p> <p>à / at 1,00 km</p>		

1er e-RVGE

Déviation 2 ES / SS 7 Vologne

PAGE

SECTION 4

PK 96
ES/SS 7

à CH7A

DISTANCE TOTALE

37,98 km

D8

DISTANCE		DIRECTIONS	INFORMATIONS	DISTANCE DEGRESSIVE
TOTALE	PARTIELLE			
9,55	0,00		<p>Case 14 page 102</p> <p>Modifiée / Modified</p> <p>!! sortie itinéraire ES / Exit SS itinerary !!</p>	28,43
9,68	0,13	<p>1</p>	<p>D44</p> <p>BRUYÈRES 6 LAVAL s/ V. 3</p>	28,30
11,08	1,40	<p>2</p>	SRP / FMR D44	26,90
12,76	1,68	<p>3</p>	SRP / FMR D44	25,22
13,38	0,62	<p>4</p>	<p>D44</p> <p>BRUYÈRES 2</p>	24,60

Assistance interdite sur l'ensemble du parcours

1er e-RVGE

Déviation 2 ES / SS 7 Vologne

PAGE

SECTION 4



PK 96
ES/SS 7

à CH7A





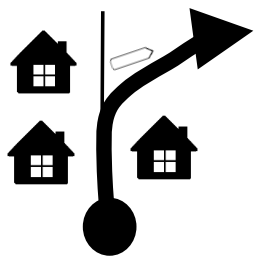
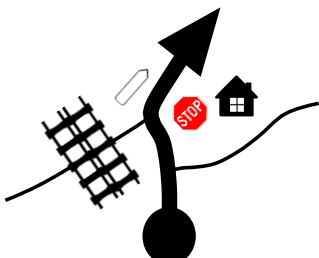
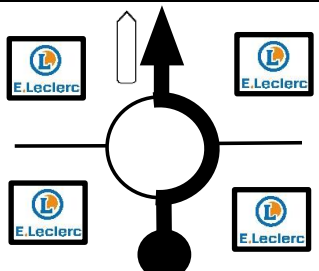









DISTANCE TOTALE

37,98 km

D9







DISTANCE		DIRECTIONS	INFORMATIONS	DISTANCE DEGRESSIVE
TOTALE	PARTIELLE			
14,17	0,79	 <p>5</p>	SRP / FMR D44	23,81
14,82	0,65	 <p>6</p>	<p>D44g</p> <p>GÉRARDMER CORCIEUX</p> <p>CHAMP LE DUC</p> <p>Z.A. BARBAZAN</p>	23,16
15,52	0,70	 <p>7</p>	<p>D423</p> <p>GÉRARDMER CORCIEUX</p> <p>Z.A. de Borémont</p>	22,46
15,97	0,45		<p>D423</p> <p>CORCIEUX GÉRARDMER</p> <p>LAVELINE DEVANT BRUYÈRES</p> <p>GRANGES SUR VOLOGNE</p>	22,01
16,08	0,11	 <p>8</p>	SRP / FMR D423	21,90

1er e-RVGE				
Déviation 2 ES / SS 7 Vologne			PAGE D10	
SECTION 4	PK 96 ES/SS 7	à CH7A		DISTANCE TOTALE 37,98 km

DISTANCE		DIRECTIONS	INFORMATIONS	DISTANCE DEGRESSIVE
TOTALE	PARTIELLE			
16,57	0,49	<div style="text-align: center;">    9 </div>	SRP / FMR D423	21,41
18,37	1,80	<div style="text-align: center;">    10 </div>	SRP / FMR D423	19,61
19,84	1,47	<div style="text-align: center;">    11 </div>	SRP / FMR D423	18,14
20,92	1,08	<div style="text-align: center;">    12 </div>	SRP / FMR D423	17,06
21,44	0,52	<div style="text-align: center;">    13 </div>	!! ATTENTION / WARNING RADAR !!	16,54

Assistance interdite sur l'ensemble du parcours

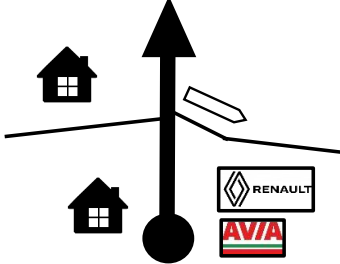
1er e-RVGE				
Déviation 2 ES / SS 7 Vologne			PAGE D11	
SECTION	4	PK 96 ES/SS 7 à CH7A		DISTANCE TOTALE 37,98 km

DISTANCE		DIRECTIONS	INFORMATIONS	DISTANCE DEGRESSIVE
TOTALE	PARTIELLE			
21,67	0,23	   <div style="border: 1px solid black; padding: 2px; display: inline-block;">14</div>	SRP / FMR D423	16,31
22,93	1,26	  	SRP / FMR D423	15,05
23,08	0,15	 <div style="border: 1px solid black; padding: 2px; display: inline-block;">15</div>		14,90
			<p>puis reprendre / then resume</p> <p style="color: red;">Case 43 page 109</p> <p>à / at 1,00 km</p>	





1er e-RVGE

PAGE

Déviation 1 ES / SS 11 Le Haut du Tôt

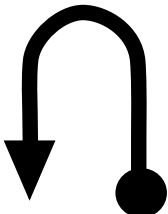

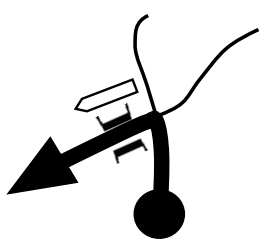

D12

SECTION 5 DES 11 à CH 12 DISTANCE TOTALE 4,42 km

DISTANCE		DIRECTIONS	INFORMATIONS	DISTANCE DEGRESSIVE
TOTALE	PARTIELLE			
0,00	0,00	 <p>1</p>	<p>Demi-tour sur ligne de départ / Half-lap on the starting line :</p> <p>DES 11</p>	4,42
0,66	0,66	<p>ROCHESSON</p> <p>2</p>	<p>SRP / FMR</p>	3,76
0,83	0,17	 <p>3</p>	<p>D23</p> <p>SAPOIS 4 VAGNEY 6</p>	3,59
1,00	0,17	<p>D23</p> <p>ROCHESSON</p> <p>4</p>	<p>SRP / FMR D23</p>	3,42
3,19	2,19	<p>!!!</p>  <p>5</p>	<p>D23^F</p> <p>1.5 GERBAMONT</p> <p>6 BASSE ^S/ LE RUPT</p> <p>0.3  Saut du Bouchot</p>	1,23

Assistance interdite sur l'ensemble du parcours

1er e-RVGE			
			PAGE
Déviation 1 ES / SS 11 Le Haut du Tôt			D13
SECTION	5	DES 11 à CH 12	

DISTANCE		DIRECTIONS	INFORMATIONS	DISTANCE DEGRESSIVE
TOTALE	PARTIELLE			
3,40	0,21	 <div style="border: 1px solid black; padding: 2px; display: inline-block;">6</div>	SRP D23 ^F / FMR D23 ^F	1,02
3,67	0,27	<div style="border: 1px solid black; padding: 2px; display: inline-block; margin-bottom: 5px;">D23^F</div> <div style="border: 2px solid red; padding: 5px; display: inline-block; margin-bottom: 5px;">GERBAMONT</div> <div style="border: 1px solid black; padding: 2px; display: inline-block;">7</div>	SRP D23 ^F / FMR D23 ^F	0,75
3,89	0,22	  <div style="border: 1px solid black; padding: 2px; display: inline-block;">8</div>	<div style="border: 1px solid black; padding: 5px; display: inline-block; margin-bottom: 5px;">C9</div> 	0,53
			<p>puis reprendre / then resume</p> <p style="color: red;">Case 30A page 150</p> <p>à / at 0,45 km</p>	

1er e-RVGE

PAGE

Déviation 2 ES / SS 11 Le Haut du Tô





D14

SECTION 5 PK 25 ES/SS 11 à CH 12 DISTANCE TOTALE 8,36 km

DISTANCE		DIRECTIONS	INFORMATIONS	DISTANCE DEGRESSIVE
TOTALE	PARTIELLE			
2,52	0,00	<p>1</p>	<p>Case 4 page 144</p> <p>Modifiée / Modified</p> <p>!! sortie itinéraire ES / Exit SS itinerary !!</p>	5,84
5,05	2,53	<p>2</p>	SRP / FMR D23 _G	3,31
6,19	1,14			2,17
6,25	0,06	<p>3</p>	SRP / FMR D23	2,11
7,13	0,88	<p>4</p>		1,23

Assistance interdite sur l'ensemble du parcours

1er e-RVGE			
			PAGE
Déviation 2 ES / SS 11 Le Haut du Tôt			D15
SECTION	5	PK 25 ES/SS 11 à CH 12	

DISTANCE		DIRECTIONS	INFORMATIONS	DISTANCE DEGRESSIVE
TOTALE	PARTIELLE			
7,34	0,21	 <div style="border: 1px solid black; padding: 2px; display: inline-block;">5</div>	SRP D23 ^F / FMR D23 ^F	1,02
7,61	0,27	<div style="border: 1px solid black; padding: 2px; display: inline-block; margin-bottom: 5px;">D23^F</div> <div style="border: 2px solid red; padding: 5px; display: inline-block; margin-bottom: 5px;">GERBAMONT</div> <div style="border: 1px solid black; padding: 2px; display: inline-block;">6</div>	SRP D23 ^F / FMR D23 ^F	0,75
7,83	0,22	  <div style="border: 1px solid black; padding: 2px; display: inline-block;">7</div>	<div style="border: 1px solid black; padding: 5px; display: inline-block; margin-bottom: 5px;">C9</div> 	0,53
			<p>puis reprendre / then resume</p> <p style="color: red;">Case 30A page 150</p> <p>à / at 0,45 km</p>	

1er e-RVGE

Déviation 1 ES / SS 9 Les Trois Coles

PAGE

SECTION 4 DES 9 à CH 9A DISTANCE TOTALE 15,71 km

Déviation 1 ES / SS 12 Les Trois Coles

D16

SECTION 5 DES 12 à CH 12A DISTANCE TOTALE 16,75 km

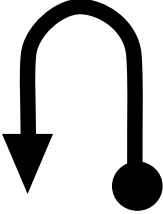
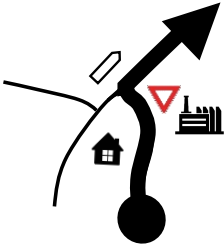
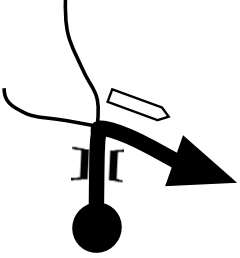
DISTANCE		DIRECTIONS	INFORMATIONS	DISTANCE DEGRESSIVE
TOTALE	PARTIELLE			
0,00	0,00	 <p>1</p>	<p>Demi-tour sur ligne de départ / Half-lap on the starting line :</p> <p>DES 9 DES 12</p>	15,71
0,59	0,59	 <p>2</p>	<p>D23^F</p> <p>ROCHESSON 4 GÉRARDMER 15</p>	15,12
1,29	0,70	 <p>3</p>	<p>D23</p> <p>ROCHESSON 3 GÉRARDMER 14</p>	14,42
3,48	2,19	<p>D23</p> <p>ROCHESSON</p> <p>4</p>	SRP / FMR D23	12,23
5,53	2,05	<p>D23</p> <p>ROCHESSON</p> <p>70</p> <p>5</p>	SRP / FMR D23	10,18

Assistance interdite sur l'ensemble du parcours

1er e-RVGE				
Déviation 1 ES / SS 9 Les Trois Cols				PAGE D17
SECTION	4	DES 9 à CH 9A	DISTANCE TOTALE 15,71 km	
Déviation 1 ES / SS 12 Les Trois Cols				
SECTION	5	DES 12 à CH 12A	DISTANCE TOTALE 16,75 km	

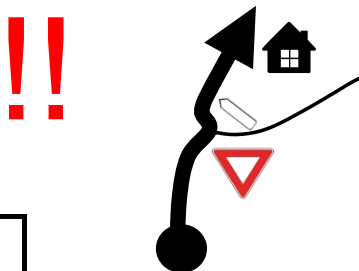
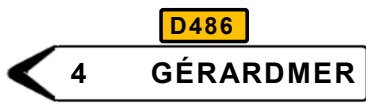
DISTANCE		DIRECTIONS	INFORMATIONS	DISTANCE DEGRESSIVE
TOTALE	PARTIELLE			
7,68	2,15	<div style="border: 1px solid black; padding: 5px; display: inline-block;"> Les Truches <i>C^{ne} de ROCHESSON</i> </div>  <div style="border: 1px solid black; padding: 2px; display: inline-block; width: 20px; text-align: center;">6</div>	SRP / FMR D23	8,03
10,15	2,47	<div style="border: 1px solid black; padding: 5px; display: inline-block;"> Les Bas Rupts <i>C^{ne} de GÉRARDMER</i> </div> <div style="border: 1px solid black; padding: 2px; display: inline-block; width: 20px; text-align: center;">7</div>	SRP / FMR D23	5,56
11,56	1,41	 <div style="border: 1px solid black; padding: 2px; display: inline-block; width: 20px; text-align: center;">8</div>		4,15
			<p>puis reprendre / then resume</p> <p>Case 34 page 130 Case 34 page 159</p> <p>à / at 2,93 km</p>	

1er e-RVGE

Déviation 2 ES / SS 9 Les Trois Cols



PAGE

SECTION 4 PK 54 ES/SS 9 à CH 9A DISTANCE TOTALE 26,73 km

Déviation 2 ES / SS 12 Les Trois Cols

D18

SECTION 5 PK 54 ES/SS 12 à CH 12A DISTANCE TOTALE 25,69 km

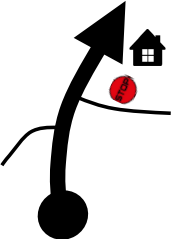
DISTANCE		DIRECTIONS	INFORMATIONS	DISTANCE DEGRESSIVE
TOTALE	PARTIELLE			
5,39	0,00		<p>Case 12 page 126 Case 12 page 155</p> <p>Modifiée / Modified</p> <p>!! sortie itinéraire ES / Exit SS itinerary !!</p>	21,34
5,47	0,08	<p>1</p> 	SRP / FMR D34	21,26
7,19	1,72	<p>2</p> 	SRP / FMR D34	19,54
7,74	0,55	<p>3</p> 	S.I. et SRP / N.I. and FMR	18,99
			<p>puis reprendre / then resume</p> <p>Case 26 page 129 Case 26 page 158</p> <p>à / at 1,62 km</p>	